

Eastwood[®]

DO THE JOB RIGHT.[®]

Item #16075

ROLLING SHOP TRAY

INSTRUCTIONS



The **EASTWOOD ROLLING SHOP TRAY**, featuring a height adjustable 14-gauge steel Tray with rubber mat, is perfect for rolling tools and parts right to the job. The rotating tray feature provides on-location support for computers or shop manuals, as well as space-saving storage. The heavy, all steel design holds up to 100 lbs. [45.36kg].

CONTENTS

- (1) Base Assembly - [A]
- (1) Post Assembly with Gusset Leg - [B]
- (4) Casters - [C]
- (2) Plastic Locking Knobs - [D]
- (1) Lanyard/Hitch Pin Ass'y - [E]
- (1) Tray Mount - [F]
- (5) Square Plastic Endcaps - [H]
- (1) Tray Support Assembly - [I]
- (1) Tray - [J]
- (1) 26.13" x 17.75" x .13"
(663mm x 450mm x 3mm)
Rubber Tray Mat - [K]
- (4) M12 x 50mm Bolts
- (4) 12mm Washers
- (4) M6 x 25mm Phillips Pan Head Screws
- (4) M6 Nuts
- (4) 6mm Washers

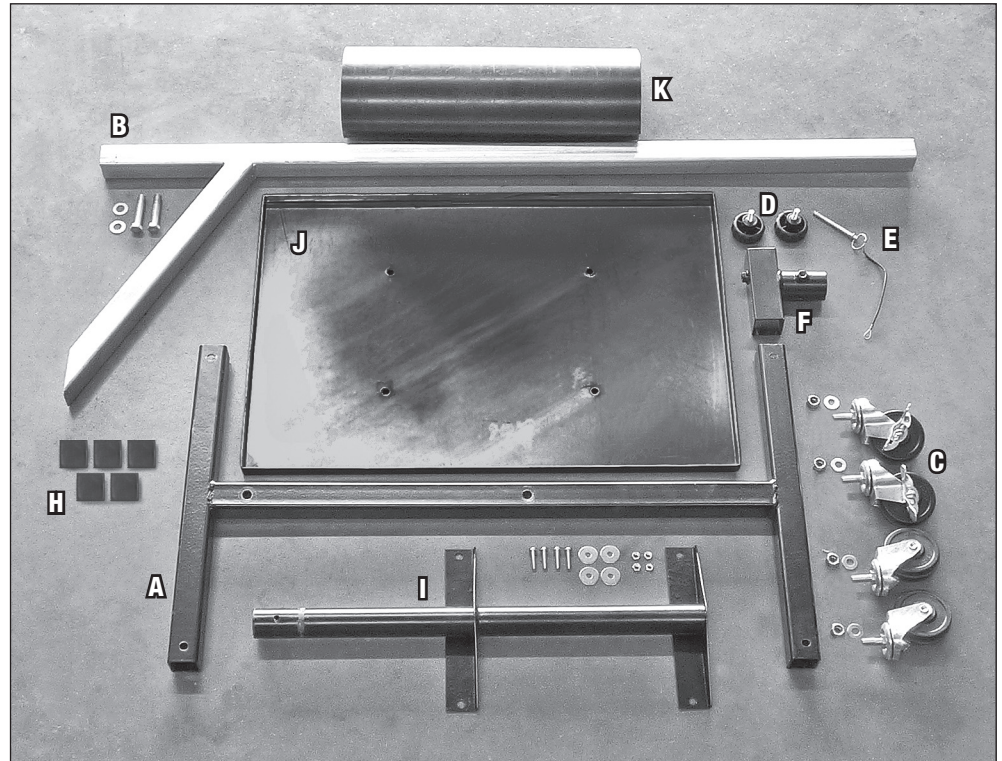

TOOLS REQUIRED

- 10mm wrench
- 17mm wrench
- #2 Phillips screwdriver
- Small hammer or mallet

SPECIFICATIONS

- Maximum Weight Limit:** 100 lbs. [45.36kg.]
- Tray Dimensions:** 30" x 19.88" [76cm. x 50.5cm.]
- Tray Height Range (level position):** 18" - 48" [460cm.-1220cm.]
- Angle Range from Level Position:** 90° (180° total range)

SAFETY INFORMATION

The following explanations are displayed in this manual, on the labeling, and on all other information provided with this product:

⚠ DANGER

DANGER indicates a hazardous situation which, if not avoided, will result in death or serious injury.

⚠ WARNING

WARNING indicates a hazardous situation which, if not avoided, could result in death or serious injury.

⚠ CAUTION

CAUTION used with the safety alert symbol, indicates a hazardous situation which, if not avoided, could result in minor or moderate injury.

⚠ NOTICE

NOTICE is used to address practices not related to personal injury.



⚠ READ INSTRUCTIONS

- Thoroughly read and understand this manual before using.
- Save for future reference.



⚠ WARNING FALL HAZARD!

- Awkward, out of balance body positions may be attempted while trying to reach specific areas of objects placed on the Rolling Shop Tray during use. Failure to ensure proper footing can quickly result in a fall which could inflict serious personal injury or property damage.



- Always work in a clean, uncluttered environment.
- Be sure there is sufficient working room around the Rolling Shop Tray to allow for safe working practices.
- This Rolling Shop Tray is designed for use in supporting projects during the working process only.

DO NOT exceed the rated 100 lbs. [45.36kg.] weight capacity.

DO NOT use as a seat.

DO NOT stand on the Rolling Shop Tray.

DO NOT attempt to ride on the Rolling Shop Tray.

DO NOT use the Rolling Shop Tray for storage.



⚠ CAUTION INJURY HAZARD!

- This Rolling Shop Tray has rotating/moveable components that can pinch or crush. Keep fingers and hands away from pinch points when operating or adjusting.
- Heavy objects placed upon the Rolling Shop Tray can fall quickly causing severe injury! Do not adjust the Rolling Shop Tray while it is loaded.

ASSEMBLY

⚠ CAUTION

CAUTION: The Eastwood Rolling Shop Tray consists of cumbersome metal components which can cause potentially serious injuries, if allowed to drop. Avoid pinching hands while handling parts during assembly and wear thick, well-fitting work gloves to prevent cuts from handling sharp metal. The use of safety shoes is strongly recommended.

ASSEMBLY

- Working on a clean, flat and level floor, place the Base Assembly [A] on edge with the end having the through hole downward (FIG 1).
- Set the Post Assembly [B] with the threaded hole on the bottom of the Main Post placed over the through hole toward the end of the Base Assembly [A] and Gusset Leg over the through hole toward the end of the Base Assembly then thread the (2) M12 x 50mm Bolts with M12 flat washers and lock washers through the Base Assembly and into the Post Assembly. Tighten bolts firmly with a 17mm wrench (FIG 1).

⚠ NOTICE

Do not overtighten or crushing of the square tube will occur.

- With the assembly still on the floor, place the threaded post of a Caster through one of the through holes located at the underside, outer ends of the Base Assembly legs (FIG 2).

⚠ NOTICE

There are 2 Locking Brake and 2 Non-Locking Casters. To help prevent falling over when the Tool Tray is moved, it is best to place both Locking Casters at the open end of the Rolling Tool Tray Assembly.

- Add an M10 lock washer and nut, repeat for remaining three Casters then tighten all nuts firmly using an 17mm wrench.
- Slip the Loop of the Hitch Pin/Lanyard [E] over the threaded post of a Knob [D] (FIG 3).
- Thread the Knob [D] into the threaded hole of the round tubular spindle on the Tray Mount [F] (FIG 3).
- Thread the other Knob [D] into the threaded hole of the square tube on the Tray Mount [F] (FIG 3).

⚠ NOTICE

When viewed from the side, the round tubular spindle of the Tray Mount [F] is welded on at an upward angle (FIG 3). The Tray Mount MUST be installed over the Post Assembly with the spindle angled upward.

FIG. 1

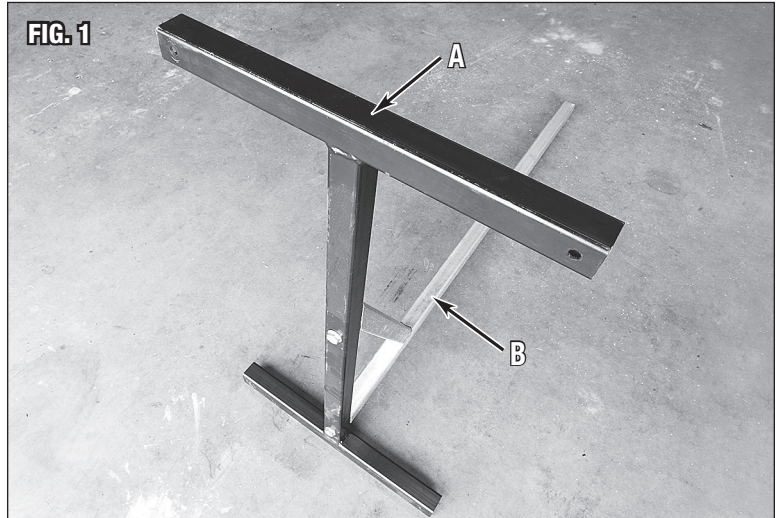

FIG. 2

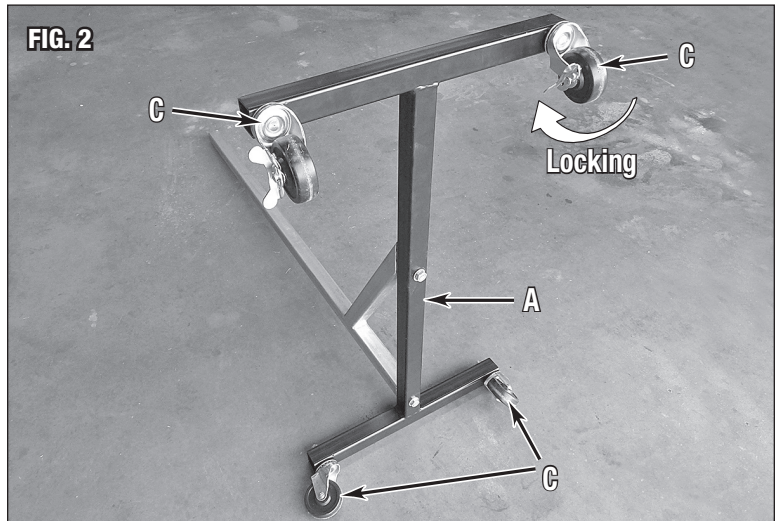
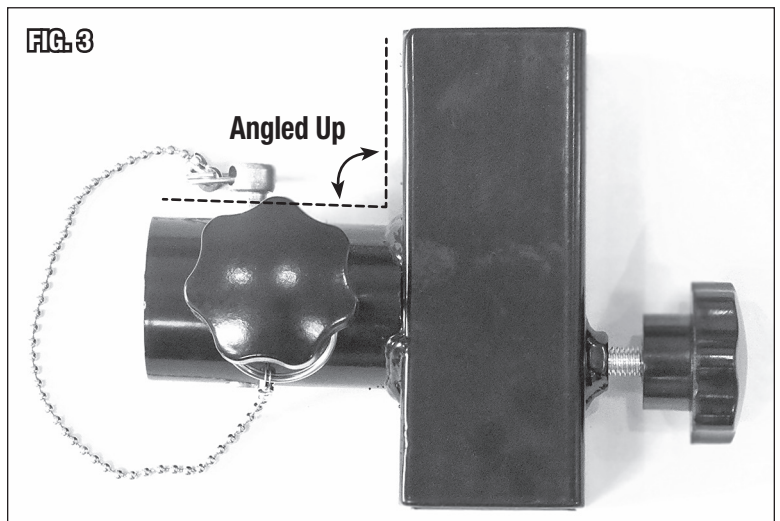
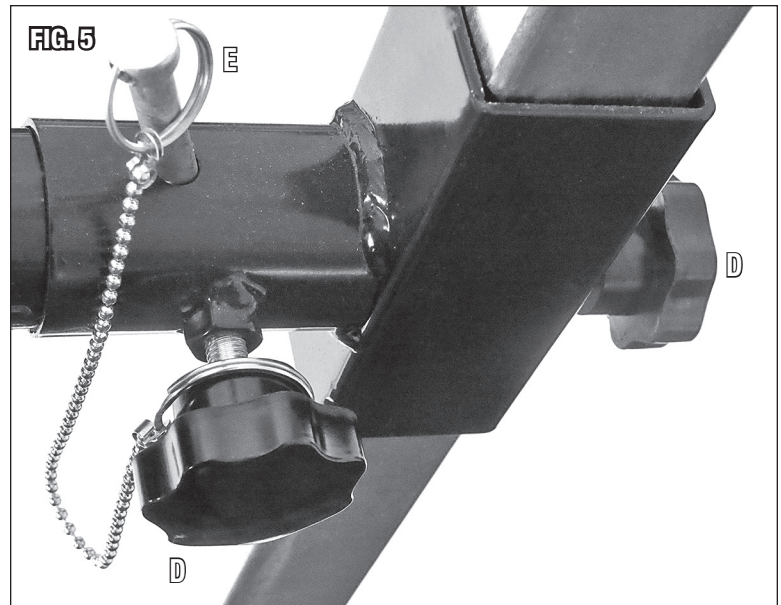
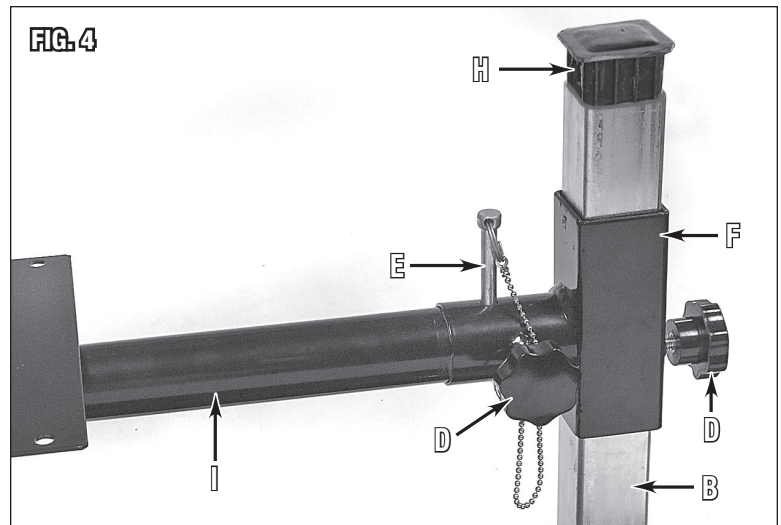

FIG. 3



- Stand the assembly up on its Casters then slip the open square tubular section of the Tray Mount [F] over the top of the Post Assembly (FIG 4).
- Tighten the Knob [D] securely to keep the Tray Mount [F] from dropping (FIG 4).
- Install the five Tube Endcaps [H] into the upper open end of the Post Assembly and the Base Assembly [A] adjacent to the Casters. Tap in place gently using a hammer (FIG 4).
- Slide the open round tubular section of the Tray Support Assembly [I] into the round tubular spindle of the Tray Mount [F] (FIG 4).
- Rotate the attached Tray Support Assembly so that the flanged surfaces of the Cross members are facing upward (FIG 4).
- Line up the holes in the Tray Mount [F] and Tray Support Assembly [I] then fit the Hitch Pin [E] through the holes locking the Tray Support Assembly in a fully horizontal position (FIG 5).
- Tighten Knob (D) to secure the Tray Support Assembly [I] (FIG 4).
- Set the Tray [J] with the flanged sides facing upward and on the top of the exposed flanges of the Tray Support Assembly [I] and line up the screw holes.
- Place the (4) 6mm x 25mm pan head Philips screws through the holes in the Tray and Tray Support Assembly, add nuts and washers then tighten all screws firmly using a 10mm wrench and a #2 Phillips.
- Add Rubber Tray Mat [K] to Tray and the Rolling Shop Tray is now ready for use.



OPERATION

⚠ CAUTION INJURY HAZARD!
This Rolling Shop Tray has rotating/moveable components that can generate crushing and bending forces if allowed to move suddenly which can quickly cause severe injury! Keep fingers, hands, and feet away from moving parts when operating.

⚠ CAUTION INJURY HAZARD!
Heavy objects placed upon the Rolling Shop Tray can fall quickly causing severe injury! Keep hands and feet clear of areas under the Rolling Shop Tray when adjusting or moving.

RAISE AND LOWER TRAY

- Gripping the tray firmly, loosen the Knob on the rear of the Tray Mount and slowly raise or lower the Tray as required.
- Be sure to tighten the Knob securely when adjustment is completed.

ROTATE TRAY

- Gripping the tray firmly, remove Hitch Pin [E], loosen the Knob on the side of the Tray Mount and rotate the Tray as required (FIG 6).
- Insert Hitch Pin [E] to securely lock the Tray in the horizontal position.

⚠ CAUTION INJURY HAZARD!
Heavy objects placed upon the Rolling Shop Tray can fall quickly, causing severe injury. The rotating Tray **MUST** be locked in the horizontal position for safe operation with heavy loads.

- Be sure to tighten the Knob securely when adjustment is completed.

LOCK/UNLOCKING CASTER BRAKES

⚠ CAUTION INJURY HAZARD!
Attempting to move the Rolling Tool Tray with one or both brakes locked could result in it falling over suddenly which can quickly cause severe injury! Use extreme caution when moving the Rolling Tool Tray.

- Moving the rotating lever (at the wheel end) upward will release Locking Brake while rotating the lever downward will release the Brake (FIG 7).

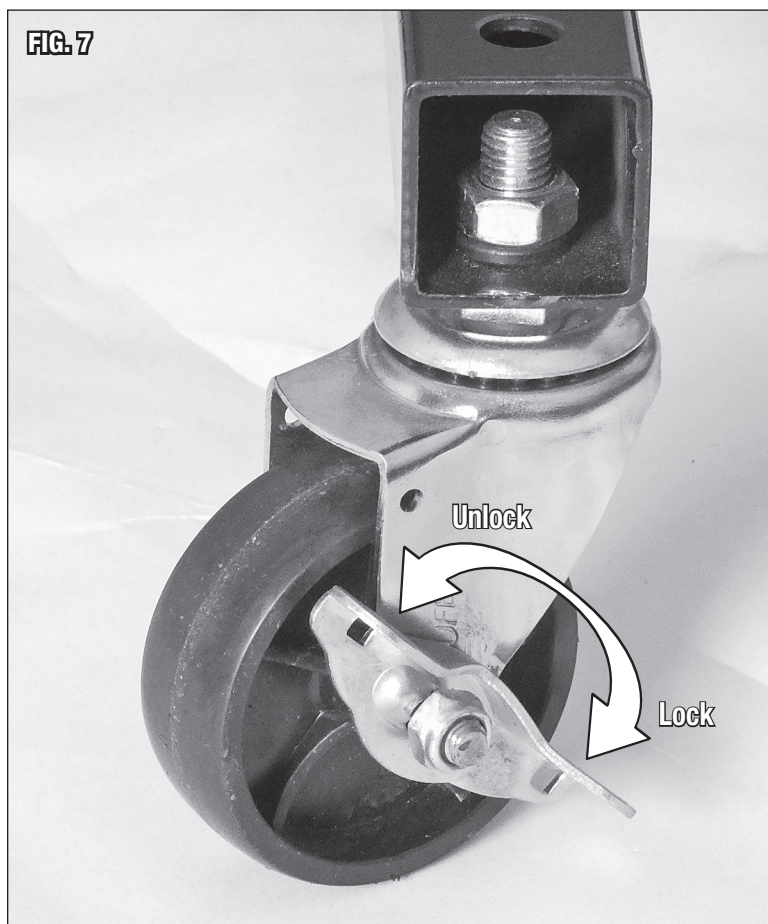
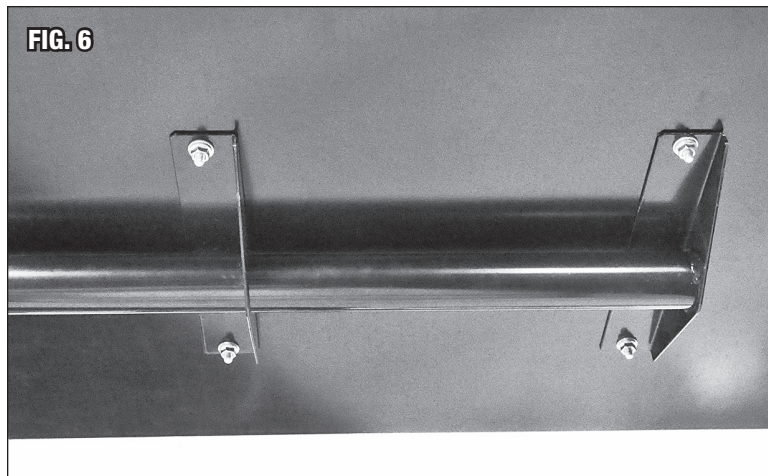

If you have any questions about the use of this product, please contact

The Eastwood Technical Assistance Service Department: 800.343.9353 >> email: techelp@eastwood.com

PDF version of this manual is available at eastwood.com

The Eastwood Company 263 Shoemaker Road, Pottstown, PA 19464, USA 800.343.9353 eastwood.com

© Copyright 2018 Easthill Group, Inc. 9/18 Instruction item #16075Q Rev 2