



**DO THE JOB RIGHT.<sup>®</sup>**

Item #31539

# **HEAVY DUTY BODY CART**

## **INSTRUCTIONS**

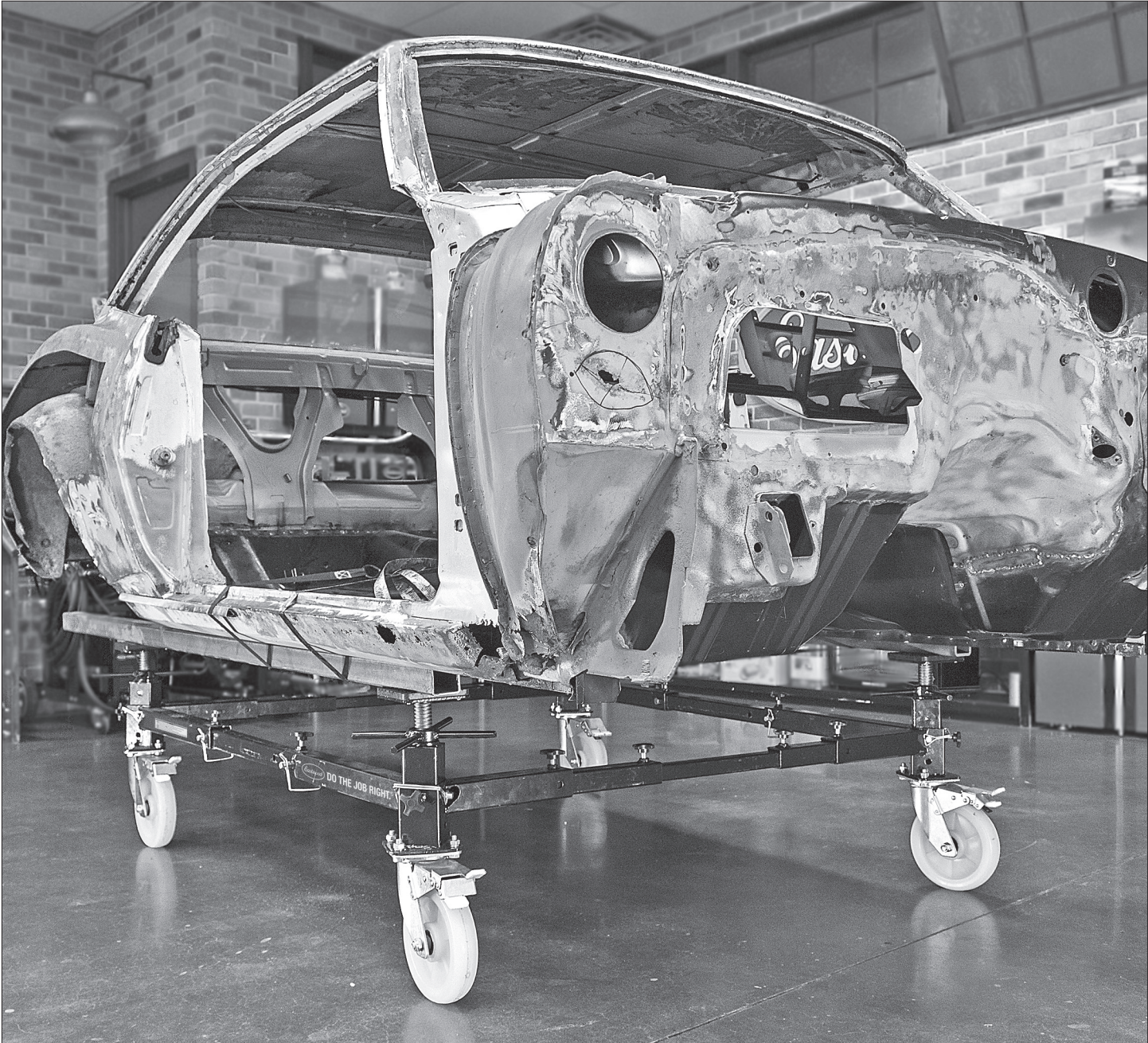

The **EASTWOOD HEAVY DUTY BODY CART** features an all steel support structure and oversized 8" swivel casters to support up to a total loaded weight of 2000 lbs. [908kg.] yet is completely portable for rolling body shells and pickup beds to the job and project storage. A generous 57" [1.45m] x 70" [1.78m] span will accommodate large vehicle bodies and projects.

## CONTENTS

### COMPONENTS:

- (2) Long/Short Corner Assemblies - [A]
- (2) Short/Long Corner Assemblies - [B]
- (2) Long 40mm Square Tube, Intermediate Connectors - [C]
- (4) Short 40mm Square Tube, Intermediate Connectors - [D]
- (2) 30mm Square Tube Inner Connectors - [E]
- (4) Locking Swivel Casters - [F]
- (4) Corner Blocks - [G]
- (4) Acme Thread Jacking Spinners - [H]
- (4) Acme Thread Support Pads - [J]

### HARDWARE:

- (16) M10 x 30mm Bolts - [K]
- (16) M10 Flat Washers - [L]
- (16) M10 Lock Washers - [M]
- (16) M10 Nuts - [N]
- (16) M10 Knob Bolts - [P]
- (4) 12mm Short Locking Pins - [R]
- (4) 12mm Long Locking Pins - [S]

## TOOLS REQUIRED

Two 17mm wrenches (not included).

## SPECIFICATIONS

<b>Max. Weight Capacity:</b>	2000lb [908kg]
<b>Overall Clearance Height (Pads at lowest position):</b>	19" [406mm]
<b>Overall Extended Height (Pads at highest position):</b>	20.5" [520mm]
<b>Assembled Body Cart weight:</b>	151 lbs. [68.5kg.]
<b>Overall Extended Length:</b>	57" [1.45m]
<b>Overall Extended Width:</b>	70" [1.78m]

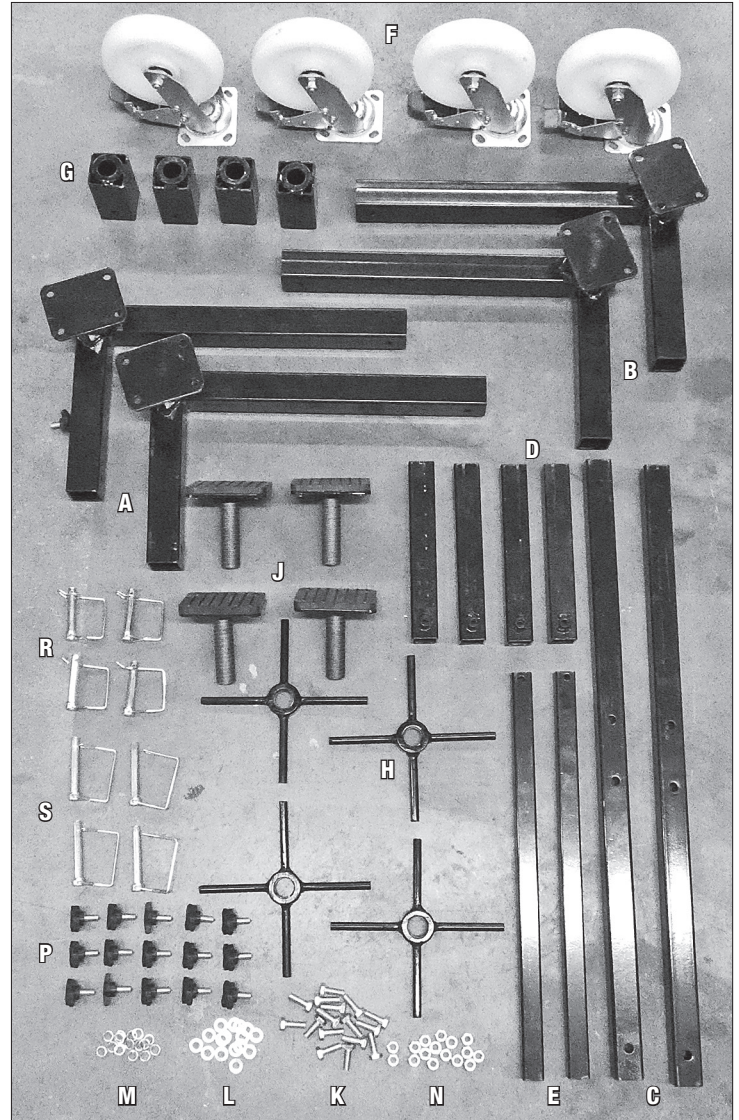

# SAFETY INFORMATION

The following explanations are displayed in this manual, on the labeling, and on all other information provided with this product:

## **⚠ DANGER**

DANGER indicates a hazardous situation which, if not avoided, will result in death or serious injury.

## **⚠ WARNING**

WARNING indicates a hazardous situation which, if not avoided, could result in death or serious injury.

## **⚠ CAUTION**

CAUTION used with the safety alert symbol, indicates a hazardous situation which, if not avoided, could result in minor or moderate injury.

## **⚠ NOTICE**

NOTICE is used to address practices not related to personal injury.

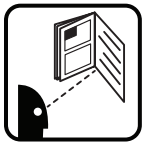

### **⚠ READ INSTRUCTIONS**

- Thoroughly read and understand this manual before using.
- Save for future reference.



### **⚠ WARNING SEVERE INJURY OR DEATH HAZARD!**

- **DO NOT** attempt to move Body Cart on sloped surfaces while loaded.
- **DO NOT** concentrate a heavy load to either side or end of the Body Cart. This can cause the balance to shift suddenly, tipping the Body Cart and its load which can quickly cause severe injury! Any uneven weight bias of the load **MUST** be known before attempting to place it on the Body Cart
- **DO NOT** exceed the rated 2000 lbs. [908kg.] weight capacity.
- **DO NOT** use to support humans or animals.
- **DO NOT** climb on the Body Cart.
- **DO NOT** use the Body Cart to support items other than auto body shells or pickup beds.
- **DO NOT** attempt to transport this Body Cart with a load attached by any hauling method.
- **DO NOT** use with lifting devices and/or chains, cables or ropes that are frayed, twisted, kinked or otherwise damaged.
- **DO NOT** remove or cover any of the factory supplied labels or warnings! They include specific safety information that must be communicated to future users.



### **⚠ WARNING FALL HAZARD!**

- Awkward, out of balance body positions may be attempted while trying to reach specific areas of objects placed on the Body Cart during use. Failure to ensure proper footing can quickly result in a fall which could inflict serious personal injury or property damage.



### **⚠ CAUTION PINCH/CRUSH HAZARD!**

- This Body Cart has moveable components that can crush and pinch. Keep fingers and hands away from pinch points when operating.

# ASSEMBLY PREPARATION

## **⚠ CAUTION** INJURY HAZARDS!

The Eastwood Body Cart consists of heavy metal components (151 lbs. [68.5kg.] assembled weight) which can cause potentially serious injuries if allowed to drop. Avoid pinching hands while handling parts during assembly.

- Obtaining the assistance of a helper during assembly is necessary. **DO NOT** attempt to construct this Body Cart without assistance!
- The use of ANSI approved safety shoes, head protection gear and eye protection is necessary.
- Perform assembly in a large, uncluttered area close to area of intended usage.
- Allow sufficient area for operator and helper to remain clear when choosing operating area.
- Use only on a firm, smooth, level and clean work surface. **DO NOT** use on a sloped or rough textured surface, earth, grass, sand, gravel or any other loose surface.
- **DO NOT** attempt to move Body Cart on sloped surfaces while loaded.
- **DO NOT** attempt to raise or lower the Support Pads while the Body Cart is supporting a load.

## **⚠ NOTICE**

To prevent scratches and damage to the finish of the Body Cart components, it is strongly advisable to use cardboard, carpet, blankets etc. covering a minimum 10' x 10' area before beginning assembly.

# ASSEMBLY

## JOIN LONG/SHORT CORNER SUB-ASSEMBLIES [A] TO SHORT/LONG CORNER SUB-ASSEMBLIES [B] WITH [C] TO CREATE TWO FRAME HALVES

Note that the Long/Short [A] & Short/Long Corner [B] Assemblies are mirror images of one another (FIG 1).

All Square Tubes *MUST* be installed with the through holes punched in the sides in the *HORIZONTAL* position.

1. Assemble one entire side of the Body Cart frame by placing one each Long/Short [A] & Short/Long Corner [B] Assembly on the floor with the **Longer** arms facing another and resting on their caster mounting square flanges (FIG 1).
2. Slip one end of a Long 40mm Square Tube, Intermediate Connector [C] into the **Long** square tubing arm of [A].
3. Slip the opposite end of the Long 40mm Square Tube, Intermediate Connector [C] into the **Long** square tubing arm of [B] (FIG 2).
4. Thread two 10mm Knob Bolts [P] into the threaded bosses at the outer ends of the long arms and lightly hand tighten to keep tubes from sliding (FIG 2).
5. Repeat above steps 1, 2, 3 & 4 for remaining opposite frame side, Long/Short [A] & Short/Long Corner [B] and Intermediate Connector [C] Assemblies.

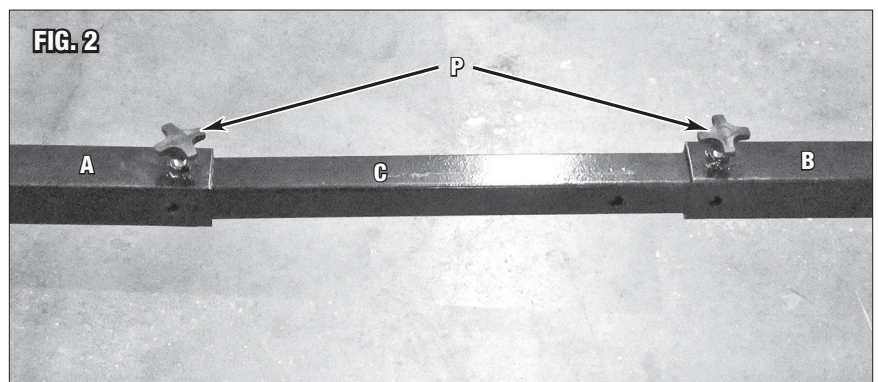
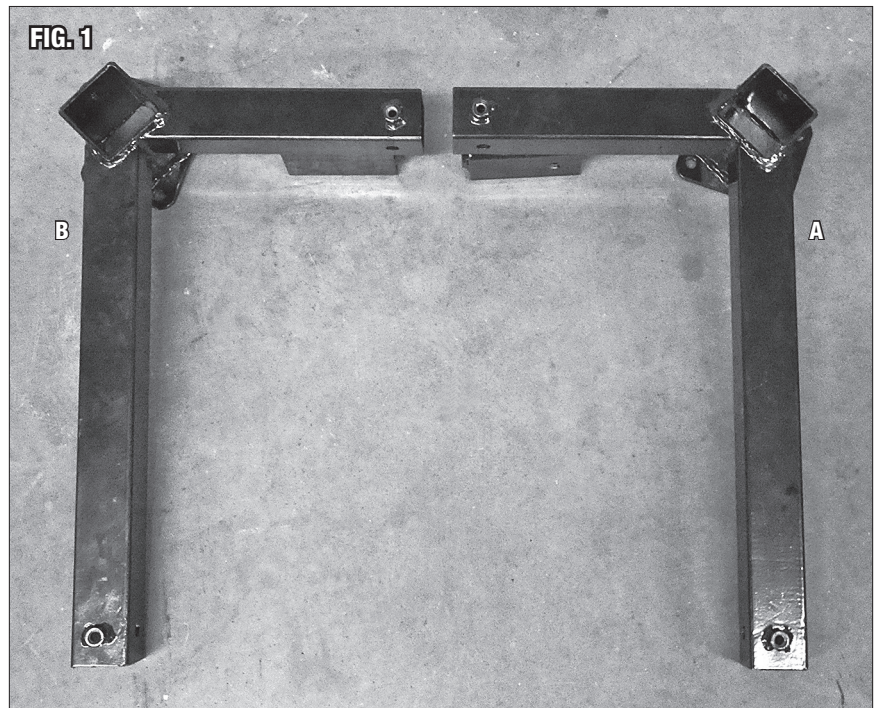

## JOIN FRAME HALVES

Note once again that the two frame side Assemblies are mirror images of one another.

All Square Tubes **must** be installed with the through holes punched in the sides in the **Horizontal** position.

When assembled properly, the insertion of telescoping tubes will be in this sequence (**FIG 3**).

1. Arrange each frame half assembly on the floor with the **Shorter** arms facing another and resting on their caster mounting square flanges.
2. Slip one end of each of the four Short 40mm Square Tube, Intermediate Connectors [**D**] into the of the four **Short** square tubing arms of the Corner Assemblies [**A**] & [**B**].
3. Thread two 10mm Knob Bolts [**P**] into the threaded bosses at the outer ends of the short arms and lightly hand tighten to keep tubes from sliding.
4. Slide one end of each of the two 30mm Square Tube, Inner Connectors [**E**] into the four Short 40mm Square Tube, Intermediate Connectors [**D**] (**FIG 4**).
5. Thread two 10mm Knob Bolts [**P**] into the threaded bosses at the outer ends of the Intermediate Connectors [**D**] and lightly hand tighten to keep tubes from sliding.

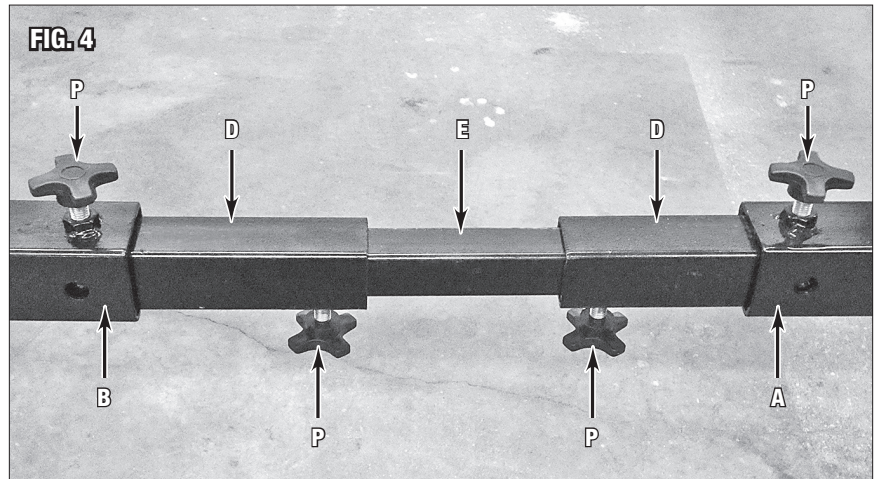
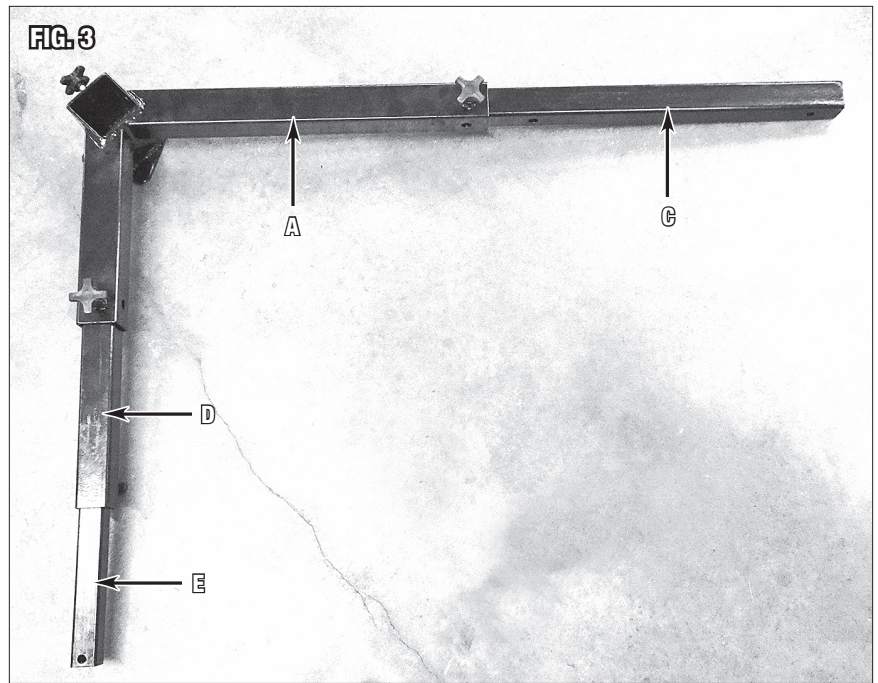

## MOUNTING LOCKING SWIVEL CASTERS TO FRAME ASSEMBLY

Note that each corner of the assembled frame will need to be lifted and supported while each Caster is attached.

### **⚠ CAUTION** INJURY HAZARDS!

The Eastwood Body Cart consists of heavy metal components which can cause potentially serious injuries if allowed to drop. Avoid pinching hands while handling parts during assembly. Obtaining the assistance of a helper during assembly is necessary. **DO NOT attempt to construct this Body Cart without assistance!**

- With two 17mm wrenches (not included), attach the four Swivel Casters **[F]** using sixteen M10 x 30mm Bolts **[K]**, M10 Flat Washers **[L]**, M10 Lock Washers **[M]**, and M10 Nuts **[N]**. Tighten all hardware securely (**FIG 5**).

**FIG. 5**

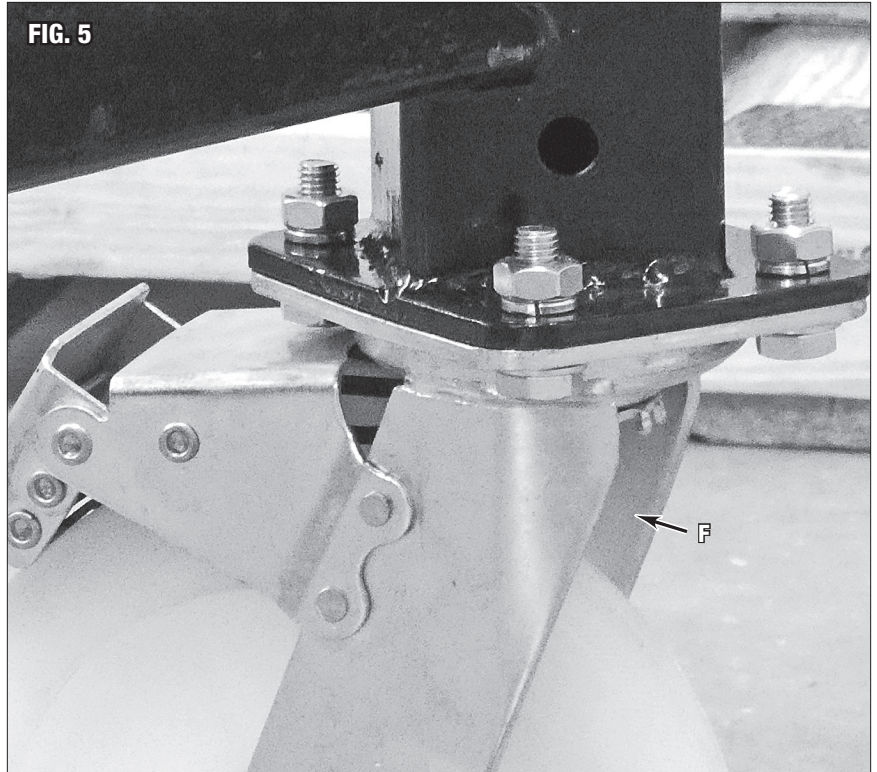

**ADD CORNER BLOCKS [G], JACKING SPINNERS [H] AND SUPPORT PADS [J] TO FRAME ASSEMBLY**

- Drop a Corner Block [G] into each of the open square tubing receptacles of the Corner Assemblies [A] & [B]. Note that the ends of the Corner Blocks with the round bores must be installed in the UP position while the through holes in the sides must go in DOWN and be aligned with the through holes in the square tubing receptacles (FIG 6).
- Thread the four Acme Threaded Jacking Spinners [H] onto the four Acme Threaded stubs of the Support Pads [J] (FIG 7).
- Set the Acme Threaded post of each of the four Support Pads and Jacking Spinner assemblies [J] & [H] into each of the Corner Blocks [G] (FIG 8).
- Thread four Knob Bolts [P] into the threaded bosses on open square tubing receptacles of the Corner Assemblies [A] & [B]. Do not tighten (FIG 8).

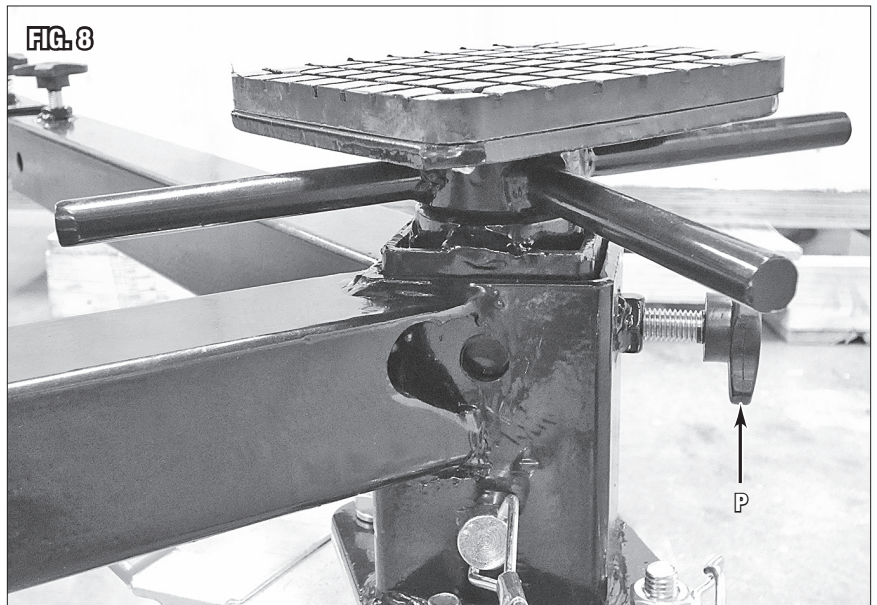
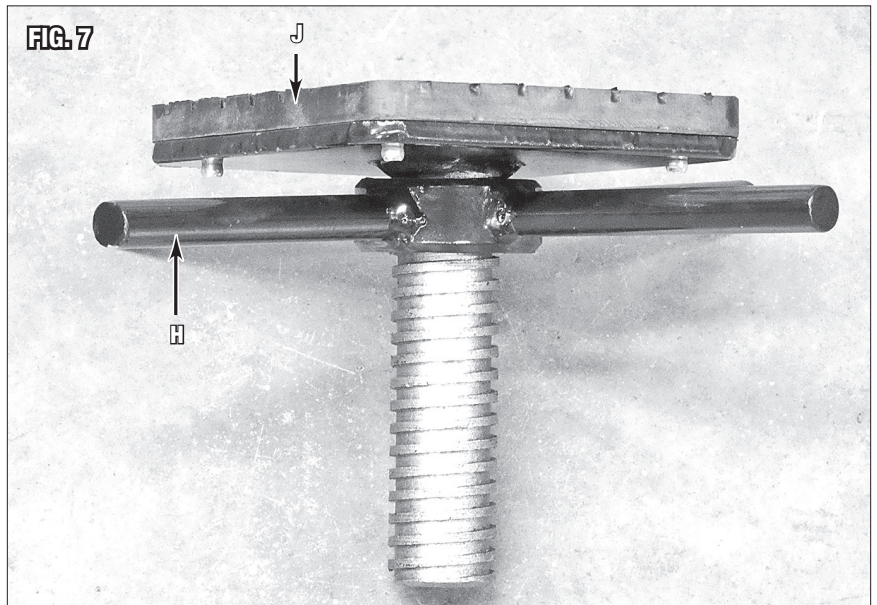
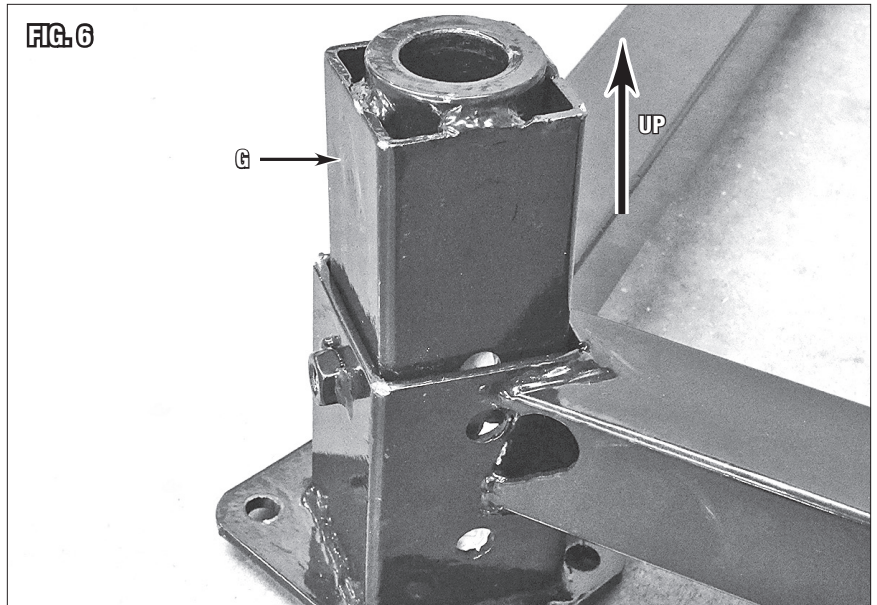

## SET-UP BODY CART FOR USE

The assembled Body Cart has limited adjustments for length and width as well as Support Pad height.

First determine where the Support Pads would be best located to safely support the subject project car body.

### LENGTH ADJUSTMENT:

- Loosen the Knob Bolts [P] on both side rails allowing the telescoping tubes to slide.
- Locate the nearest aligning through holes of the telescoping Square Tubes then insert the four 12mm Short Locking Pins [R] fully then swing the lock clips over the end of the pins to retain them (FIG 9).
- Tighten the four Knob Bolts [P] securely.

### WIDTH ADJUSTMENT:

- Loosen the Knob Bolts [P] on the on both side rails allowing the telescoping tubes to slide. Space out the overlap of the telescoping tubes as required then tighten the eight top and bottom Knob Bolts [P] securely (FIG 9).

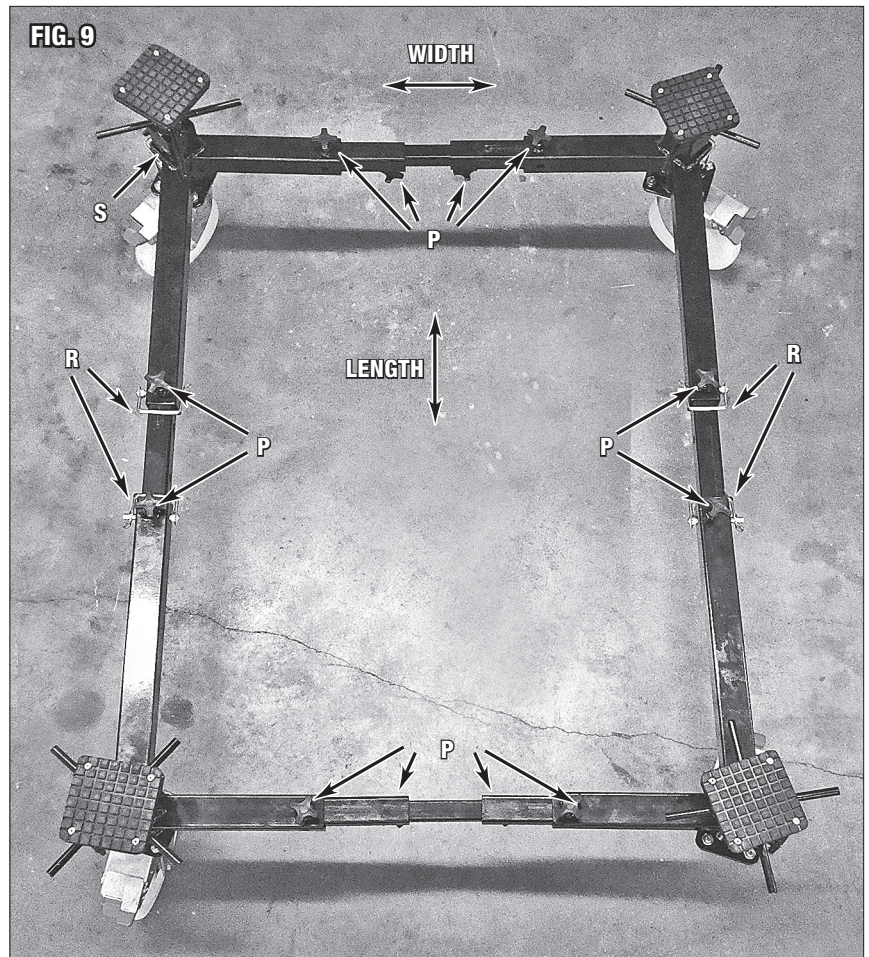



#### PAD HEIGHT INITIAL BASE ADJUSTMENT:

- Loosen the Knob Bolts [P] on open square tubing receptacles of the Corner Assemblies [A] & [B].
- Slide the Corner Blocks [G] up or down as required to align the through holes with those of the open square tubing receptacles of the Corner Assemblies [A] & [B]. Note that there are 2 sets of holes in the open square tubing receptacles of the Corner Assemblies (FIGS 10 & 11).
- Insert the four 12mm Long Locking Pins [S] fully then swing the lock clips over the end of the pins to retain them.
- Tighten the four Knob Bolts [P] securely.

#### PAD HEIGHT "FINE TUNING" ADJUSTMENT:

- Rotate the Acme Threaded Jacking Spinners [H] to raise the Support Pads [J] up or down as required to securely support the subject project car body (FIGS 10 & 11).

**CAUTION INJURY HAZARDS!**  
Store the Body Cart on a flat, level surface only to prevent possible unattended rolling and property damage.

**CAUTION INJURY HAZARDS!**  
Only release the Castor Locks when moving the Body Cart. The Castor Locks MUST be applied whenever the Body Cart is stationary.

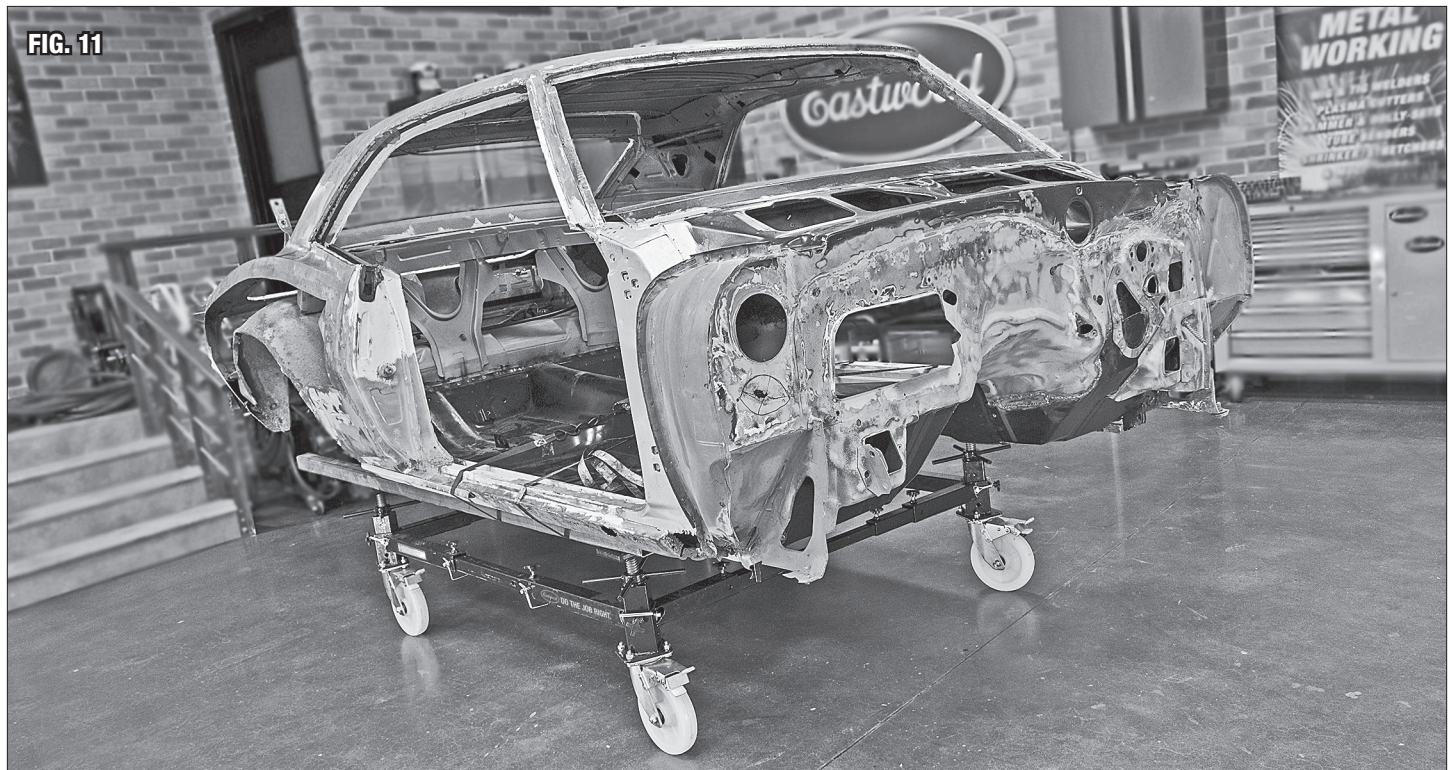
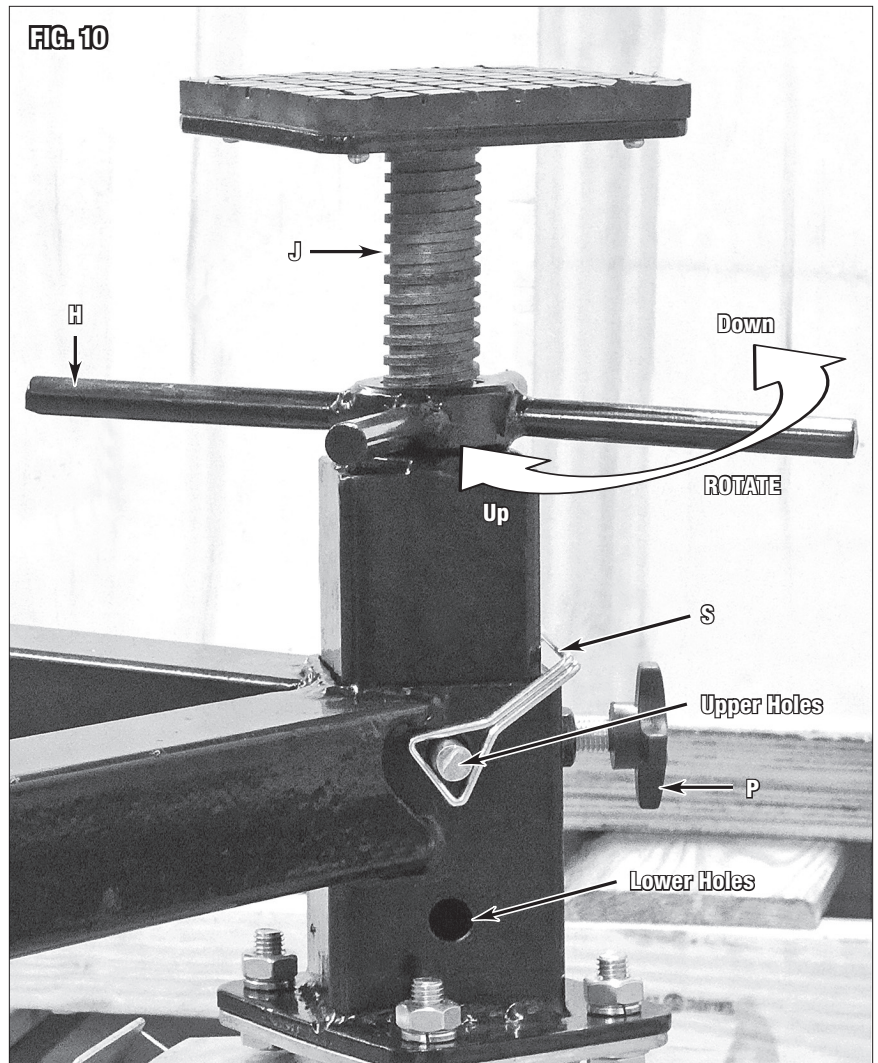

## MAINTENANCE

- Keep all moving components of the Body Cart well lubricated and free of any dirt or debris accumulations.
- The Body Cart is finished in rugged powder coating which will provide many years of effort-free beauty, however it is advisable to keep the finish clean and free from excessive dust and dirt.
- Keep the Body Cart in a clean and dry environment. **DO NOT** store it in, or expose it to a damp or wet environment.
- Occasionally inspect all components for potential damage and proper alignment. Check all hardware for tightness.
- **DO NOT** use if damage is discovered.



---

**If you have any questions about the use of this product, please contact**

The Eastwood Technical Assistance Service Department: 800.343.9353 >> email: [techelp@eastwood.com](mailto:techelp@eastwood.com)

PDF version of this manual is available at [eastwood.com](http://eastwood.com)

The Eastwood Company 263 Shoemaker Road, Pottstown, PA 19464, USA 800.343.9353 [eastwood.com](http://eastwood.com)

© Copyright 2018 Easthill Group, Inc. 8/18 Instruction item #31539Q Rev 2