

# TERAFLEX

## INSTALLATION GUIDE

# Installation Guide for the TJ RockGuard Rear Bumper Part #004666165



**Tera Manufacturing, Inc.**  
5251 South Commerce Dr.  
Murray, Utah 84107  
Phone/801.288.2585  
Fax/801.713.2313  
www.teraflex.biz

### Installation:

1. Remove the rear factory bumper and all associated brackets and fasteners
2. Ensure the back of the frame is free from rust or cracks. If not, repair the rear cross member before installing the new TeraFlex bumper.



3. There are two angled reinforcing brackets for the rear cross member that are installed outside of the frame. Hold each bracket up in place and working through the rectangular hole in the bottom of the frame put a nut up inside the frame. Put the 1/2 x 1 bolt and flat washer in each hole

- but don't tighten them more than finger tight at this point.
4. Have a helper hold the new RockGuard bumper in place and using 4 of the supplied 1/2 x 1 bolts with split lock washers go through the back of the reinforcing bracket and through the factory cross member into the threaded hole in the new bumper.
5. Install 2 of the factory bolts, 12mm x 55 mm up through the bottom of the RockGuard bumper and into the frame.
6. Before tightening the bolts make sure the bumper is properly aligned with the frame and the body tub, then torque all the mounting bolts.

### Torque Specs:

- 1/2 x 1 bolts – 65 ft. lbs.
- 12 mm bolts - 60 ft. lbs.

1 2 3 4 5 6 7 8

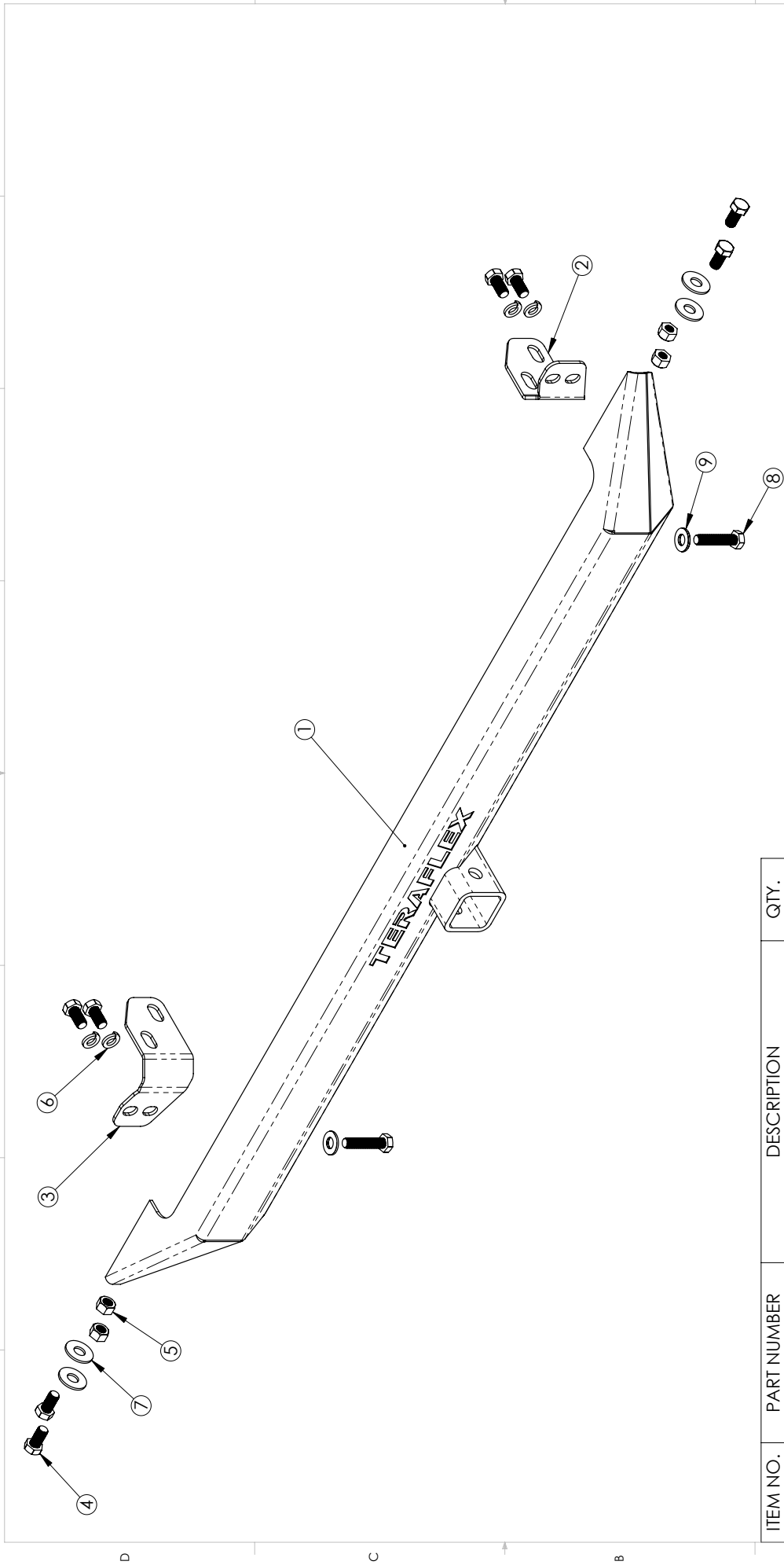

UNLESS OTHERWISE SPECIFIED: DIMENSIONS ARE IN INCHES TOLERANCES: FRACTIONAL ±1/32 ONE PLACE DECIMAL ±0.03 TWO PLACE DECIMAL ±0.015 THREE PLACE DECIMAL ±0.008 ANGLE ±1° BEND ±2°		DRAWN	DATE
CHECKED	NAME	TRNG	DD MM/YY
MATERIAL	MATERIAL		
WEIGHT	28.27 Lbs Kg		
<b>PROPRIETARY AND CONFIDENTIAL</b> THE INFORMATION CONTAINED IN THIS DRAWING IS THE SOLE PROPERTY OF TERA MANUFACTURING, AN AFFILIATE OF TERA GROUP, INC. ANY REPRODUCTION OR TRANSMISSION OF THIS DRAWING WITHOUT THE WRITTEN PERMISSION OF TERA MANUFACTURING IS PROHIBITED.			
HEAT TREATMENT	HEAT TREATMENT	FINISH	FINISH
SIZE	DWG. NO.	REV	REV
B	004666165		
SCALE: 1:4.5	DO NOT SCALE DRAWING	SHEET 1 OF 1	

ITEM NO.	PART NUMBER	DESCRIPTION	QTY.
1	00BR59	TJ REAR BUMPER	1
2	00BR59-1R	RIGHT HAND FRAME SUPPORT	1
3	00BR59-1L	LEFT HAND FRAME SUPPORT	1
4	000238	1/2" x 1" - 13 UNC BOLT	8
5	00032	1/2"-13 UNC NUT	4
6	00035	1/2" LOCK WASHER	4
7	00037	1/2" FLAT WASHER	4
8	FACTORY	Factory Bolt 12mm x 1.25 x 55mm	2
9	FACTORY	Factory 12mm Washer	2

A B C D