

7929 Lincoln Ave. Riverside, CA 92504
 Phone: 951.689.ICON Fax: 951.689.1016

PART #	DESCRIPTION
22005	07-UP 4.5-6" JK FRONT COILOVER CONVERSION KIT

COMPONENTS INCLUDED	
(1) 124000 JK FRT TRACK BAR BRACKET (1) 124010 JK FRT LOWER CO MT (DRVR) (1) 124011 JK FRT LOWER CO MT (PASS) (1) 124012 JK FRT CO MNT (DRVR) (1) 124013 JK FRT CO MNT (PASS)	(1) 124022 JK FRT DRAG LINK (1) 124033 JK FRT CO ANCHOR (DRVR) (1) 124034 JK FRT CO ANCHOR (PASS) (1) 125101 BRAKE LINE KIT (1) 22005H HARDWARE KIT
HARDWARE INCLUDED	
22005H HARDWARE KIT - BAG 1 - STEERING & TRACK BAR	
(1) 127001 JK STEERING FLIP ADAPTER STEM (1) 127002 JK STEERING FLIP TOP DOME (1) 127003 JK STEERING FLIP TAPER SLEEVE (1) 294002 NUT PLATE 3/8-16 X 2.5 (1) 295511 JM12T ROD END F1 FIT (3) 605101 3/8-16 X 1.000 BOLT (4) 605122 3/8-16 LOCK NUT (7) 605133 3/8 FLAT WASHER	(1) 605150 3/8-16 U-BOLT 2.500 ID X 3.125 L X 1.250 THREAD (1) 605350 1/2-20 LOCK NUT (1) 605445 9/16-12 X 3.000 BOLT (1) 605450 9/16-12 LOCK NUT (2) 605455 9/16 FLAT WASHER (1) 605525 5/8-18 LOCK NUT (1) 605640 3/4-16 JAM NUT
22005H HARDWARE KIT - BAG 2 - SWAY BAR LINKS	
(2) 127014 JK FRONT SWAYBAR LINK (2) 295503 RIGHT HAND ROD END (2) 295504 LEFT HAND ROD END	(8) 605330 1/2 FLAT WASHER (4) 605350 1/2-20 LOCK NUT (2) 605355 1/2-20 JAM NUT (2) 605356 1/2-20 LEFT HAND JAM NUT
22005H HARDWARE KIT - BAG 3 - SPACERS	
(2) 127012 JK FRONT BUMP STOP SPACER 3.75" (2) 605118 3/8-16 X 4.500 ALLEN BOLT (2) 605122 3/8-16 LOCK NUT	(2) 605133 3/8 FLAT WASHER (4) 605455 9/16 FLAT WASHER
22005H HARDWARE KIT - BAG 4 - UPPER MOUNTS	
(2) 124037 JK CO ANCHOR DOUBLER (4) 154012 1/2-13 NUT TAB (4) 605101 3/8-16 X 1.000 BOLT (6) 605108 3/8-16 X 1.250 BOLT (10) 605122 3/8-16 LOCK NUT (20) 605133 3/8 FLAT WASHER (4) 605301 1/2-13 X 1.250 BOLT	(2) 605306 1/2-13 X 2.500 BOLT (2) 605322 1/2-13 LOCK NUT (8) 605330 1/2 FLAT WASHER (2) 605505 5/8-18 X 2.000 BOLT (2) 605508 5/8-18 X 1.500 BOLT (4) 605525 5/8-18 LOCK NUT (8) 605530 5/8 FLAT WASHER
22005H HARDWARE KIT - BAG 5 - LOWER MOUNTS	
(2) 139004 SLEEVE .750 X .510 X 1.450 (4) 605016 5/16 FLAT WASHER (2) 605076 5/16-18 LOCK NUT (2) 605080 5/16-18 X 1.000 BOLT (4) 605101 3/8-16 X 1.000 BOLT	(4) 605122 3/8-16 LOCK NUT (8) 605133 3/8 FLAT WASHER (2) 605311 1/2-13 X 4.000 BOLT (2) 605322 1/2-13 LOCK NUT (4) 605330 1/2 FLAT WASHER
TOOLS REQUIRED	
JACK JACK STANDS CUT-OFF WHEEL 8MM SOCKET / WRENCH 10MM SOCKET / WRENCH 15MM SOCKET / WRENCH 18MM SOCKET / WRENCH 19MM SOCKET / WRENCH 21MM SOCKET / WRENCH 1/2" SOCKET / WRENCH 9/16" SOCKET / WRENCH 3/4" SOCKET / WRENCH	15/16" SOCKET / WRENCH CENTER PUNCH HAMMER SANDER 5/16" DRILL BIT 3/8" DRILL BIT 11/32" DRILL BIT 3/4" DRILL BIT BLACK SPRAY PAINT 7/32" ALLEN WRENCH DRILL TORQUE WRENCH
TECH NOTES	
<p>1. INSTALLING THIS KIT REQUIRES AN AFTERMARKET FRONT DRIVESHAFT FOR ALL YEAR JK'S FOR CLEARANCE AT FULL DROOP. 2012-UP MODELS REQUIRE EXHAUST SPACERS FOR CLEARANCE AT FULL DROOP. 2007-11 YEARS REQUIRE TRIMMING OF FACTORY SKIDPLATE/CROSSMEMBER DEPENDING ON VEHICLE OPTIONS FOR AFTERMARKET DRIVESHAFT CLEARANCE AT FULL DROOP.</p> <p>2. THIS KIT IS ADJUSTABLE BETWEEN 4.5-6" OF LIFT FOR A STOCK EQUIPPED 4 DOOR JK. BUMPERS, WINCHES, ACCESSORIES, ETC... WILL ALTER HEIGHT RANGE. FOR BEST RIDE QUALITY ICON RECOMMENDS SETTING THIS KIT UP AT 4.5" OF LIFT.</p> <p>3. IF GOING ABOVE 4.5" OF LIFT, AN ADJUSTABLE ICON TRACK BAR IS RECOMMENDED.</p> <p>4. FAILURE TO CLEARANCE FRAME IN STEP 16 WILL LEAD TO COIL/FRAME INTERFERENCE AND POSSIBLE SHOCK SHAFT FAILURE. THIS IS NOT COVERED UNDER ICON'S WARRANTY POLICY.</p>	



WARNING!

**** READ ALL INSTRUCTIONS THOROUGHLY FROM START TO FINISH BEFORE BEGINNING INSTALLATION! IF THESE INSTRUCTIONS ARE NOT PROPERLY FOLLOWED SEVERE FRAME, SUSPENSION AND TIRE DAMAGE MAY RESULT TO THE VEHICLE!**

**** ICON VEHICLE DYNAMICS RECOMMENDS THAT YOU EXERCISE EXTREME CAUTION WHEN WORKING UNDER A VEHICLE THAT IS SUPPORTED WITH JACK STANDS.**

**** ICON VEHICLE DYNAMICS RECOMMENDS ALL INSTALLTION TO BE PERFORMED BY A PROFESSIONAL SHOP/SERVICE TECHNICIAN. PRODUCT FAILURE CAUSED BY IMPROPER INSTALLATION WILL NOT BE COVERED UNDER ICON'S WARRANTY POLICY.**

INSTALLATION

1. Using a properly rated jack, raise the front of the vehicle and support the frame rails with jack stands. Ensure the jack stands are secure and set properly before lowering the jack. NEVER WORK UNDER AN UNSUPPORTED VEHICLE. Remove wheels.

2. Remove the front track bar from the axle using a 21mm socket/wrench. The axle may move slightly when taking the bolt out. (FIGURE 1)

FIG.1



FIG.2

3. Remove the front sway bar links (will not be reused) using an 18mm and 19mm socket/wrench. (FIGURE 2)

4. Remove the steering drag link from the knuckle and the turn buckle adjuster using a 21mm and 15mm socket/wrench.

5. Disconnect the driveshaft from the front differential using a 15mm socket/wrench. An aftermarket driveshaft is required for all year JK's and driveshafts are available through ICON. 2012-up JK's will also require an ICON exhaust spacer kit for clearance at full droop. 07-11 JK's will require checking the driveshaft clearance at full droop, trimming will vary depending on which factory skid plate configuration the vehicle is equipped with.

6. Remove the front brake line bracket from the frame and axle. Brake lines will be replaced later. Free the lower bracket from the coil seat using a 10mm socket/wrench.

7. Disconnect the front differential breather tube from the frame. (*RUBICON*) Disconnect plug to electric locker at this time.

8. Support the axle housing with a floor jack and remove the front shocks using a 16mm and 18mm socket/wrench. The shocks are limiting droop, so **MAKE SURE THE AXLE IS WELL SUPPORTED, OR IT WILL FALL WHEN THE SHOCKS ARE REMOVED!**

9. Slowly lower the axle to unload the springs, then remove coil springs and rubber spring isolators.

10. Install the (127012) bump stop spacers from hardware bag 3: Drill a 3/8" hole in the middle of the lower spring seat where the bump stop hits. Using the supplied hardware from bag 3 and a 9/16" socket/wrench, fasten the bump stop spacers to the axle using 3/8" (605118) allen bolts, (605122) nuts, and (605133) washers. In bump stop hardware bag 3 there are 4 (605455) washers, these washers are used to space the skid plate down and provide clearance for the aftermarket driveshaft during droop. (FIGURE 3)

FIG.3



11. Fasten the (124010) lower coilover mount on the axle using the hardware in bag 5. Slip (124010) under the OEM shock mount and using the 2 bottom holes in the OEM shock mount and 3/8" (605101) bolts with (605122) nuts and (605133) washers to loosely attach the coilover mount. Use the supplied 5/16" (605080) bolt with (605076) nut and (605016) washers to connect the (1) aligned bolt hole that screws into the side of the bump stop mount. Install the supplied 1/2" (605311) shock bolt to line all 3 holes up and then drill the front side hole through the factory coil seat to 3/8". Install the supplied hardware. The rearward side 5/16" bolt will be removed and replaced with the supplied flange head bolt in the brake line kit during brake line installation.

12. On the driver side, begin installing the upper coil over shock mount (124012) using the hardware in bag 4. Slip the mount over the upper OEM stem top shock mount. Insert the supplied 5/8" (605508) bolts, (605530) washers, and (605525) nuts, allowing it to hang in place. Do not tighten yet. Some factory components in the wheel well may need to be loosened to ease the installation process. Place the anchor bracket on top of the coil bucket with holes facing rearward to match holes on coilover mount. Use supplied (605108) hardware to attach anchor bracket to shock mount loosely. Do not tighten yet. Some of the fender well may need to be trimmed on certain models to speed up the installation process. (FIGURE 4)

FIG.4

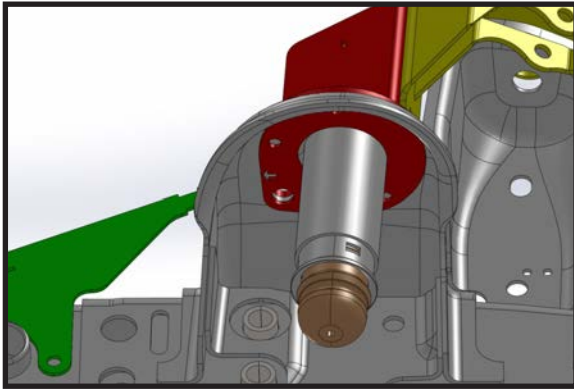

FIG.5

13. Install the supplied 5/8" (605508) bolts, (605525) nuts, and (605530) washers from bag 4. Fasten using a 15/16" socket/wrench in the existing factory hole in the coil bucket. If the anchor is not sitting flush use a clamp to bring the anchor flush with the coil bucket. Use the supplied drill plate and mark the center of the holes using a centering punch. Drill the marked holes to 3/8" and install the 3/8" (605108) hardware using a 9/16" socket/wrench. Once the anchor is fastened to the coil bucket, snug the bolts holding it to the coilover mount. (FIGURE 5)

NOTE: IF INSTALLING HYDRAULIC BUMPSTOP YOU CAN REMOVE THE DOUBLER PLATE AND REPLACE IT WITH THE BUMPSTOP MOUNT AFTER THE HOLES HAVE BEEN DRILLED.

14. Use a clamp to hold the shock mount flush to the frame to mark for drilling. The cut out should center over the hole in the frame. Center punch each hole and drill through the frame using a 1/2" drill bit. Only drill through the outer wall of the frame, don't drill through the inner wall. Install the (605301) bolts using the supplied nut tabs through the access hole in the outer wall. Fasten using a 3/4" socket/wrench. (FIGURE 6)

FIG.6



15. Tighten remaining hardware throughout the shock mount and anchor bracket using 9/16", 3/4", and 15/16" sockets/wrenches.

16. Prior to mounting the passenger side shock hoop, a small piece of the shock bucket flange needs to be trimmed. Your lift height setting and track bar adjustment will dictate how much material needs to be trimmed. At the bar minimum, ICON recommends removing the bottom corner at a 45 degree angle up to the frame. If trimming beyond a 45 degree angle, more clearance will be required. If in doubt, cycle it out. (FIGURE 7 & 8)

FIG.7



FIG.8



17. Mount the passenger side in the same manner prior to assembly portion of the rear rib will need to be cut off as shown. Certain models will require the battery tray and other components to be loosened up in order to speed up the install process and allow easier access to tighten hardware.

18. The ICON coilover can be installed at this time. Using the hardware from bag 4, fasten the 1/2" (605306) bolts, (605322) nuts and (605330) washers, then attach at the coilover to the upper shock mount first. Installation of the nut and washer on the back side is very tight. It may be necessary to pull the lower part of the shock out towards the brake caliper allowing more access behind the shock. Once the coilover is connected to the hoop and everything is tight, slowly raise the axle up to the shock to align the lower mount. Use hardware from bag 5 to fasten the 1/2" (605311) bolts, (605322) nuts, and (605330) washers.

19. Tighten all hardware on the axle shock mount that was left loose in Step 11. (FIGURE 9)

FIG.9

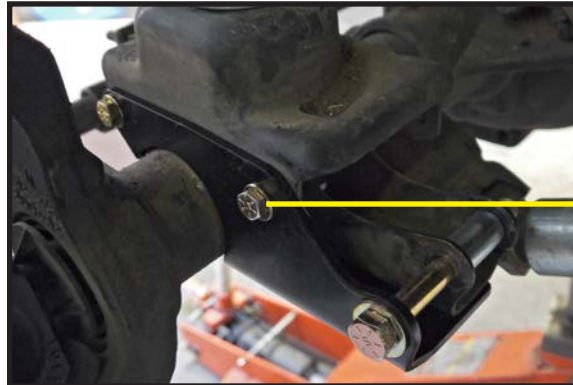

Replace with flanged bolt in (125101) brakeline kit

20. Mount the reservoir using the reservoir mount and instructions included with the coilovers.

21. Install the front track bar bracket (124000) by placing it in the factory track bar pocket. Install the factory bolt through the lower hole in the stock position using red thread locker. Install the supplied U-bolt (605150) around the axle as shown and fasten with the supplied 3/8" (605101) bolt, (605122) nut, and (605133) washer from bag 1. The pocketed nut will use the 3/8" nut tab (294002) for easier installation. Reinstall the factory track bar or ICON track bar using the supplied 9/16" (605445) bolt, (605450) nut, and (605455) washer from bag 1. (FIGURE 10)

FIG.10



22. Reconnect track bar to axle using a 21mm socket/wrench.

23. Install taper adapter into the steering knuckle as shown. Locate bag 1 and install (127001) taper on top, (127003) taper sleeve on bottom, and supplied lock nut (605525) on bottom side. (FIGURE 11)

FIG.11

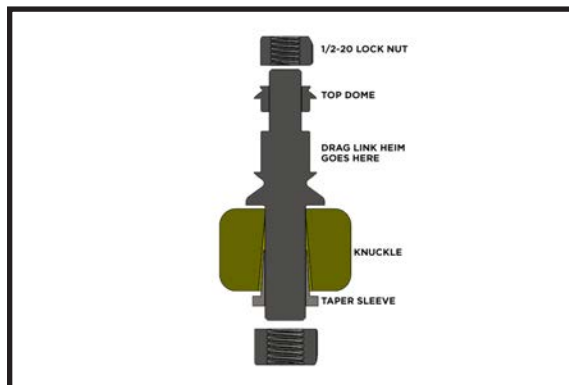

24. Assemble drag link to factory steering adjuster.

25. Install the drag link rod end over the installed taper adapter at the knuckle followed by the upper misalign (127001) and lock nut (605350).

26. (Rubicon) Reconnect the front locker solenoid.

27. Reconnect the front differential breather tube to the frame.

28. Install the supplied sway bar links from bag 2. The sway bar links are supplied loose and must be adjusted and jam nut fastened by the end user. At their minimum height they are for a kit being installed at minimum ride height, which is also ICON's recommended ride height. The studs on the rod ends are to be installed 180 degrees apart. Use a supplied (605330) washer on the both sides of the sway bar and axle mount, fasten using (605350) lock nut. At static ride height the ideal setting is so that the sway bar and link are 90 degrees to one another. (FIGURE 12)



FIG.12

29. Install the supplied brake lines per your factory service manual. The supplied brake line kit was designed to mimic late model factory routing. The installed metal bracket installs into the factory coil seat on the axle. Even if your vehicle was not equipped with this brake line routing, your stock axle has the provisions for it and the flanged bolt supplied is to go through both the lower shock bracket installed in Step 11 and fasten into the brake line bracket nut. The steel brackets are mirrored from left to right, but need to be installed on the opposite hand side in order to clear the lower coilover brackets. (FIGURE 13)



FIG.13

30. Install the ICON driveshaft (07-11 models: IVD22016) (12+ models: IVD22014) and the exhaust spacer kit (12+ models IVD22011).

31. Tighten all factory hardware to factory specs. Torque ICON supplied hardware to:

- 5/16" to 17 ft-lbs
- 3/8" to 30 ft-lbs
- 7/16" to 50 ft-lbs
- 1/2" to 75 ft-lbs
- 9/16" to 110 ft-lbs
- 5/8" to 170 ft-lbs

32. Install wheels [Torque to factory spec] and lower vehicle to the ground.

33. Have the vehicle professionally aligned.

VERIFY ALL FASTENERS ARE PROPERLY TORQUED BEFORE DRIVING VEHICLE.

RETORQUE ALL NUTS, BOLTS AND LUGS AFTER 100 MILES AND PERIODICALLY THEREAFTER.

ICON VEHICLE DYNAMICS LIMITED LIFETIME WARRANTY

ICON Vehicle Dynamics warrants to the original retail purchaser who owns the vehicle on which the product was originally installed. ICON Vehicle Dynamics does not warrant the product for finish, alterations, modifications and/or installation contrary to ICON Vehicle Dynamics instructions. ICON Vehicle Dynamics products are not designed, nor are they intended to be installed on vehicles used in race applications, for racing purposes or for similar activities. (A "race" is defined as any contest between two or more vehicles, or a contest of one or more vehicles against the clock, whether or not such contest is for a prize). This warranty does not include coverage for police or taxi vehicles, race vehicles, or vehicles used for government or commercial purposes. Also excluded from this warranty are sales outside of the United States of America and Canada.

ICON Vehicle Dynamics' obligation under this warranty is limited to the repair or replacement, at ICON Vehicle Dynamics' discretion, of the defective product. Any and all costs of removal, installation or re-installation, freight charges and incidental or consequential damages are expressly excluded from this warranty. Items that are subject to wear are not considered defective when worn and are not covered.

ICON Vehicle Dynamics components must be installed as a complete kit as shown in our current application guide. Any substitutions or exemptions of required components will immediately void the warranty. Some finish damage may happen to parts during shipping and is not covered under warranty.

This warranty is expressly in lieu of all other warranties expressed or implied. This warranty shall not apply to any product that has been improperly installed, modified or customized subject to accident, negligence, abuse or misuse.

ICON VEHICLE DYNAMICS

PERFORMANCE SUSPENSION SYSTEMS AND SHOCK ABSORBERS

7929 Lincoln Ave. Riverside, CA 92504 Phone: 951.689.ICON Fax: 951.689.1016
www.iconvehicledynamics.com



FOLLOW US ON FACEBOOK!

