

Jeep Wrangler

i209-WRA

i209-WRASXM

9" Restyle Installation Manual

- Model: Wrangler
- Model Year: 2011-2018

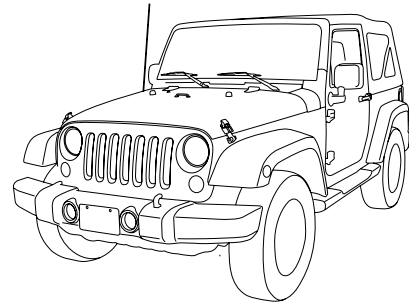

Jeep	Model	Year
	Wrangler	2011 - 2018

* The specified vehicles have been tested and have met compatibility specs at the time of testing. Compatibility is not guaranteed if the manufacturer has made production changes to the listed vehicles above.

⚠ Warning: Before you begin wiring, remove the ground wire from the negative terminal of the battery. Failing to do so can lead to electric shock, injury or damage to equipment.

Introduction

- Congratulations on purchasing the i209-WRA. This installation manual is designed to take you through the step-by-step installation of the i209-WRA into a 2011-2018 Jeep Wrangler. Please familiarize yourself with the owners manual and if you still have additional questions please call 1-800-TECH-101.



Note:

- Design and specifications are subject to change without notice for improvement.





To Ensure Safe Use, Always Follow These Precautions

- The installation of this product requires specialized skills and experience. We recommend that you have the product installed by an Alpine authorized dealer.
- Before you use this product, be sure to carefully read this installation manual and the separate user's manual so that you can use the product correctly. Alpine Electronics bears no responsibility for problems that arise as a result of failure to follow the instructions in the manuals.
- This manual includes a number of symbols that are intended to help you use the product safely, to prevent harm to you and others, and to protect against damage to property. These symbols and their meanings are listed below. Make sure you fully understand these symbols before you begin reading the main text.

Explanations of Injury and Damage That May Result from Incorrect Use

 Warning	Ignoring the content marked by this indication and using the product incorrectly is expected to lead to death or serious injury.
 Caution	Ignoring the content marked by this indication and using the product incorrectly is only expected to lead to injury or property damage.

Types of Precautions

 Forbidden	Indicates actions that are forbidden (must not be performed)	 Mandatory	Indicates actions that are mandatory (must be performed)
 Forbidden	Indicates that disassembly is forbidden.		Marks content that should receive your full attention.

 **Warning**

Do not disassemble or modify the product. Doing so could lead to an accident, fire, or electric shock.



Forbidden

Store screws and other small objects where small children cannot reach them. If one of these small objects is swallowed, consult with a doctor immediately.



When replacing fuses, be sure to use fuses with the specified current rating. Failing to do so could lead to an accident or fire.



Forbidden



Mandatory

Only connect the product to a 12 VDC negative ground car. Failing to do so could lead to an accident or fire.



Mandatory

Before you begin wiring, remove the ground wire from the negative terminal of the battery. Failing to do so could lead to electric shock or injury.



Do not cut the insulation on a cord and take power from another device. Doing so could lead to fire or electric shock.



Forbidden

Do not install the product in a location where it will obstruct the driver's forward view; interfere with the operation of the steering wheel, gearshift, or the like; or pose a threat to passengers. Doing so could lead to an accident or injury.



Forbidden

When making a hole in the vehicle body, be careful to avoid damaging pipes, the fuel tank, electrical wiring, and the like. This kind of damage could lead to an accident or fire.



When installing and grounding the product, do not use any of the bolts or nuts of the steering wheel, brakes, fuel tank, or the like. Doing so could make the brakes stop working or lead to fire.



Forbidden

Do not install the product near the passenger-side airbag. Doing so could interfere with the operation of the airbag and lead to an accident or injury.



Forbidden

Bundle cords so that they don't interfere with driving. Wrapping cords around the steering wheel, gearshift, brake pedal, or the like, could lead to an accident or damage equipment.



 **Caution**

Connect the product properly according to the instructions. Failing to do so could lead to fire or an accident.



Forbidden

Do not sandwich cords between the seat railing or allow them to touch protrusions. Resulting breaks or shorts could lead to electric shock or fire.



Do not block vents or heat sinks. Doing so could lead to fire or damage equipment.



Use the accessories according to the instructions, and attach them securely. Failing to do so could lead to an accident or damage equipment.



Forbidden

Do not install the product where it may be exposed to water or in a place with high levels of humidity or dust. Doing so could lead to fire or damage equipment.







Forbidden

The installation and wiring of this product requires specialized skills and experience. Have the product installed by an Alpine authorized dealer.

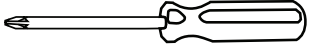

Tools Required

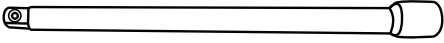
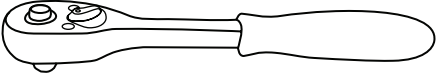
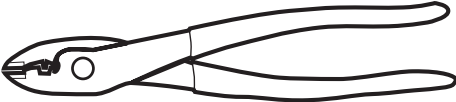
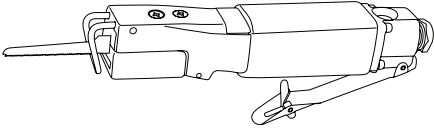
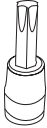
Panel Removing Tool	7mm Sockets	#2 Phillips Screwdriver
		
10mm Sockets	Extension	Ratchet
		
Wire Cutters	Air Saw	T20 Torx
		





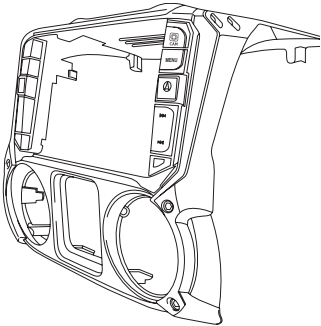
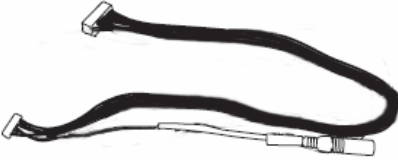
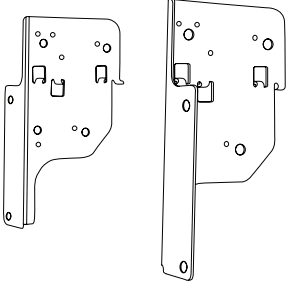
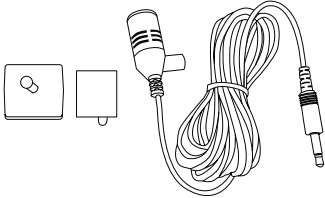
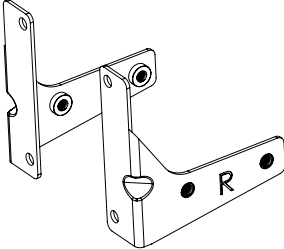
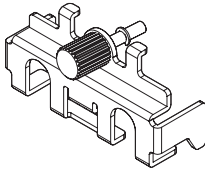

Accessory List

Installation Kit Parts (G-KTX-i209-WRA)

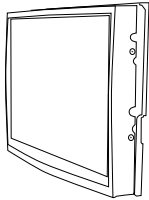
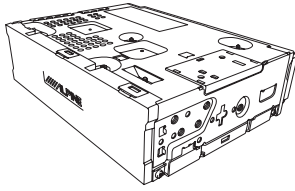
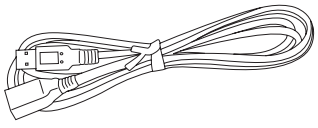
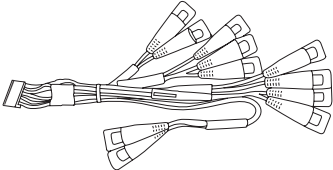
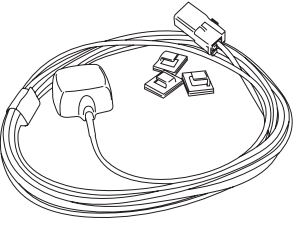

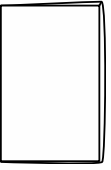
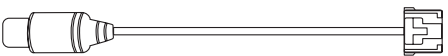
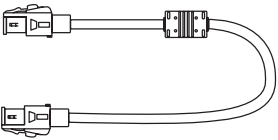
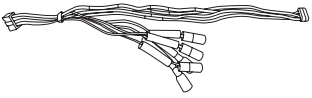
i209-WRA Radio Dash Bezel	Key Harness	Side Mounting Brackets
		
Microphone	Display Mounting Brackets	Source Unit HDMI Bracket
		

Accessory List

Head Unit Box Parts (i209)

i209 Display Unit	i209 Source Unit	USB Extension Cable
		
AUX/Pre Out Harness	GPS Antenna	Documents
		   Alpine Registration Card QRG Navigation
Direct Camera Adapter	Display Cable	Display Power Harness
		
Anti-Vibration Foam	Screws (12pcs)	SXM Tuner (included in i209-WRASXM kit only)
		

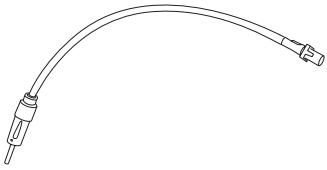
iDatalink Maestro Box Parts (ALP-MRR4/ALP-HRN-WRA3)

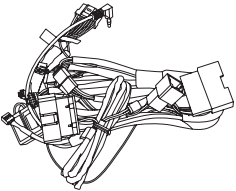
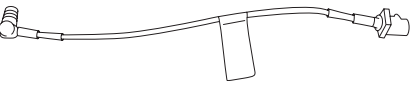
Maestro Flashing Cable	Antenna Adapter	iDatalink Maestro Module
		
Main Harness	SAT Radio Antenna Adapter	
		

Programming the iDataLink Maestro Module

1 INSTALL THE WEBLINK PLUG-IN

Go to:

idatalinkmaestro.com/plugin and follow the installation steps. The Maestro module must be programmed specifically for each vehicle and radio. Take care to enter the correct vehicle information, factory options, head unit model, and head unit serial number. The head units serial number is an alphanumeric value which is found on the head units label, underneath the bar code.

Review the System Requirements before installing.

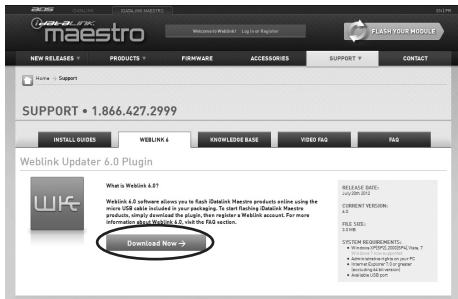

If the plugin is already installed, the caution, “The plugin is already installed” appears. Please skip to step 2.

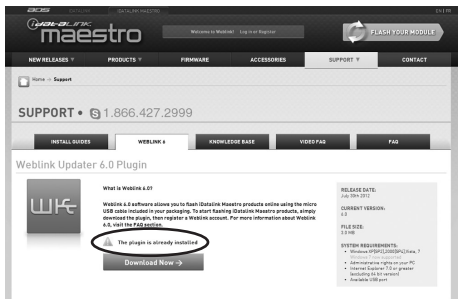

3 CONNECT YOUR MAESTRO MODULE

Use your Maestro module to connect to your PC.

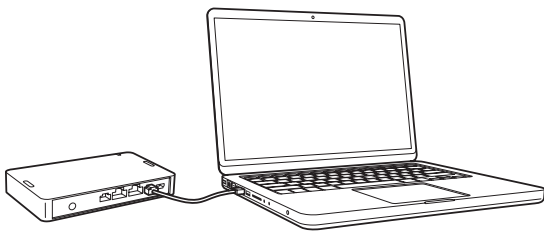

5 PROGRAM YOUR MODULE

Follow the programming steps for your vehicle.



2 REGISTER A WEBLINK ACCOUNT

Go to:

idatalinkmaestro.com/register and complete the registration process.

A confirmation email will be sent to you requiring validation.

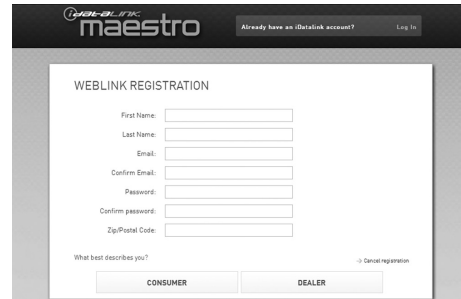

For existing customers, click log in.



4 LOG INTO WEBLINK

Go to:

idatalinkmaestro.com/login.

Enter your username and password, then click OK.



6 Once Programming is complete “FLASHING COMPLETED!” will be displayed.

Proceed to the next page to complete installation.



NOTE: If serial number is invalid, Call ADS at 1-866-427-2999 with the serial number.

Component Locations

! IMPORTANT: Follow the recommended component location shown below. Failure to do so, will result in poor GPS performance.

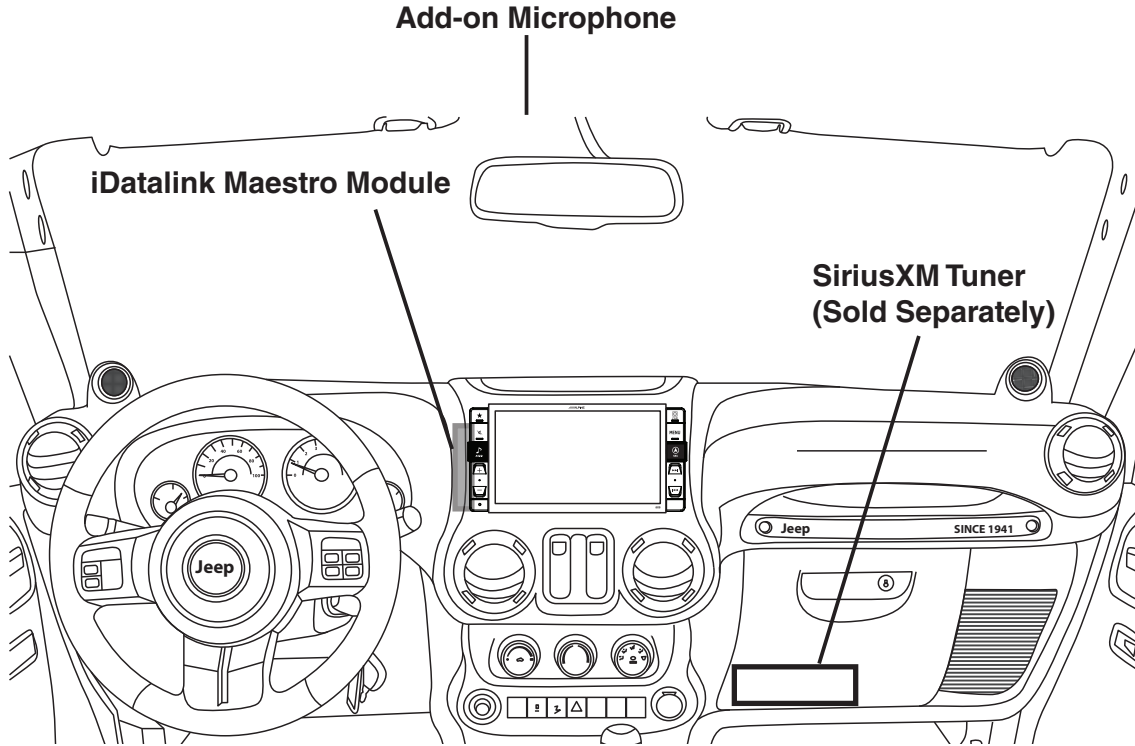

GPS Antenna Installation

! IMPORTANT: Follow the GPS antenna installation procedure shown below. Failure to do so will result in poor GPS performance for CarPlay and Android Auto.

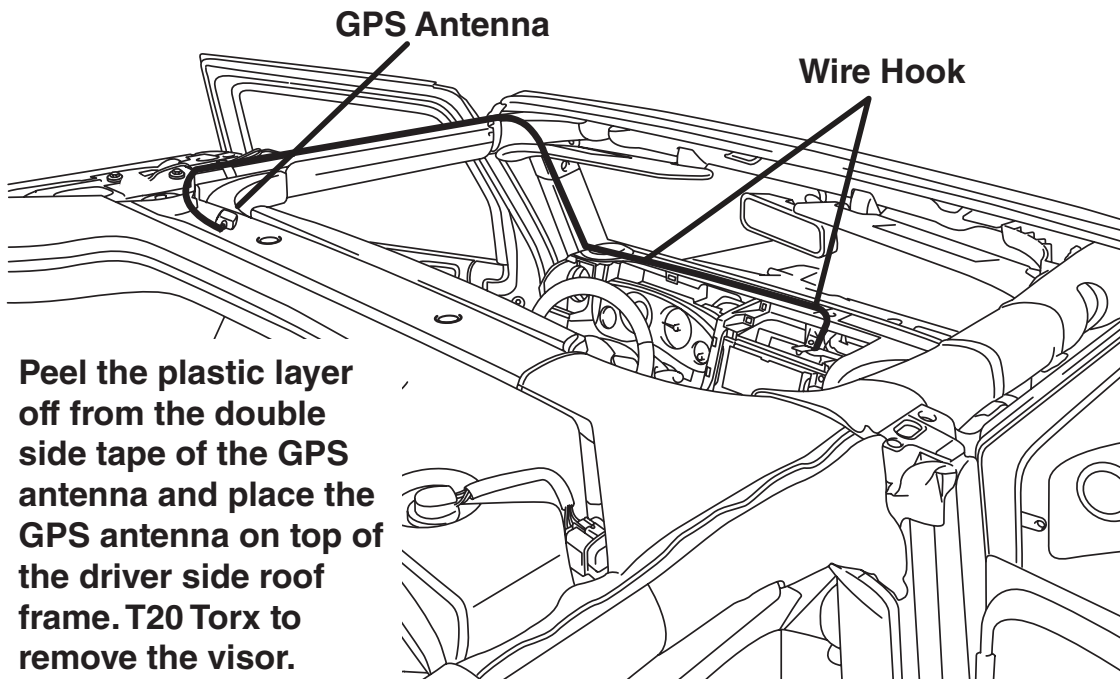

Factory Unit Disassembly Process

⚠ DISCONNECT THE BATTERY BEFORE CONTINUING. FAILURE TO DO SO WILL DISABLE MANY FEATURES.

1 Remove the rubber cover from the top center storage area and extract (1) 7mm screw.

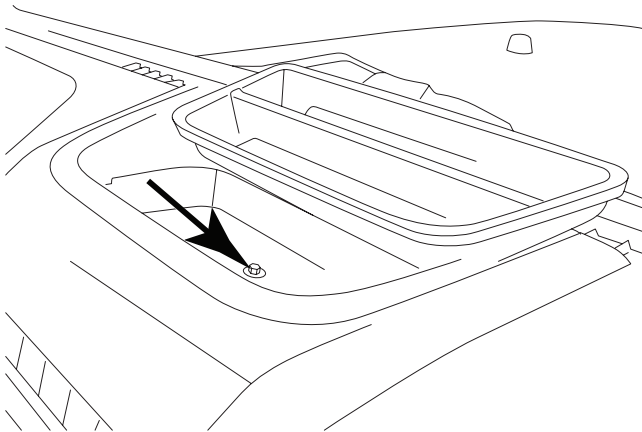

2 Remove the knee cover panel and extract (2) 7mm screws located to the right and left sides of the steering wheel column.

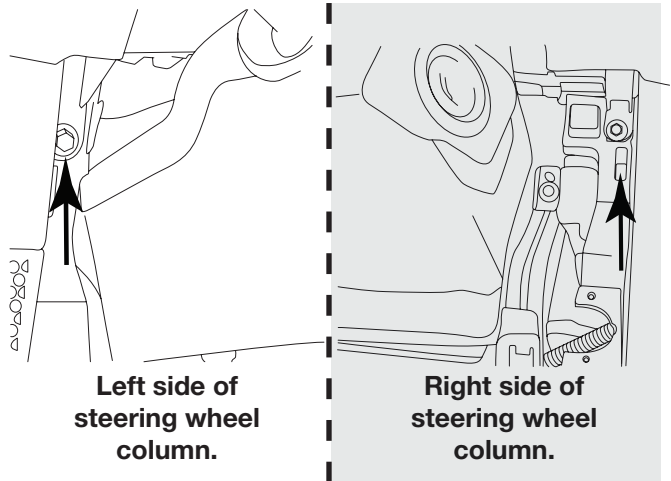

3 Remove the window switch pod using a panel removing tool and extract (1) 7mm screw.

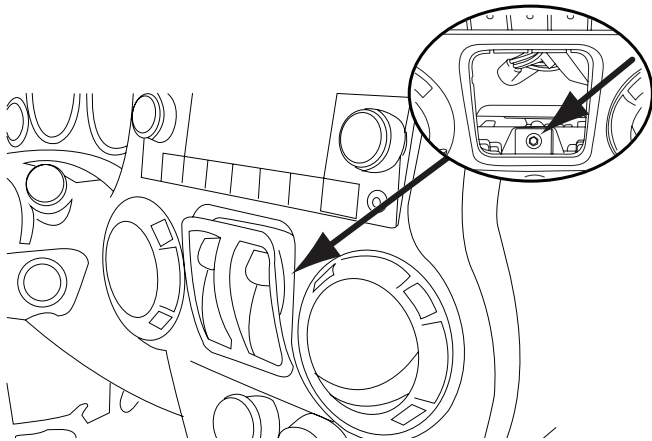

4 Remove the dash panel.

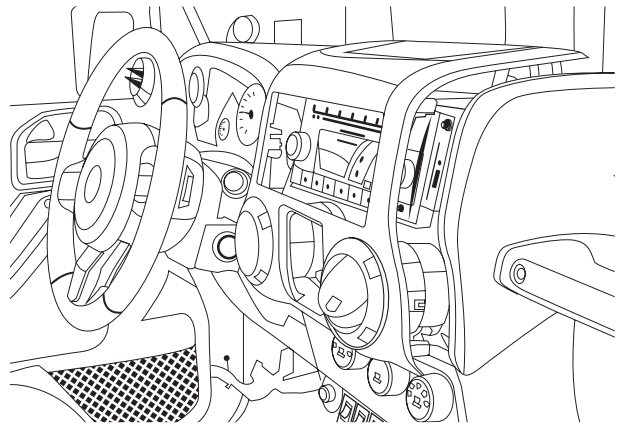

5 Extract (4) 7 mm screws and remove the factory radio.

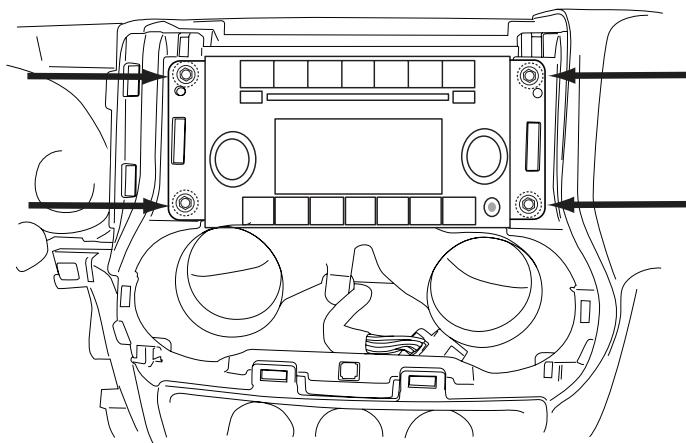

6 Extract (2) 7 mm screws from the factory radio bracket and remove it.

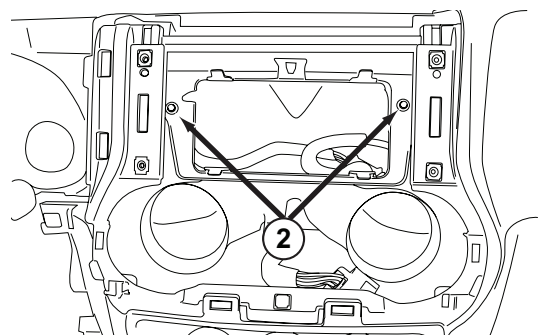

Installation Instructions

- 1** The factory dash panel needs to be trimmed to allow the new i209-WRA bezel to fit into place. Remove the highlighted area by cutting along the dashed line.

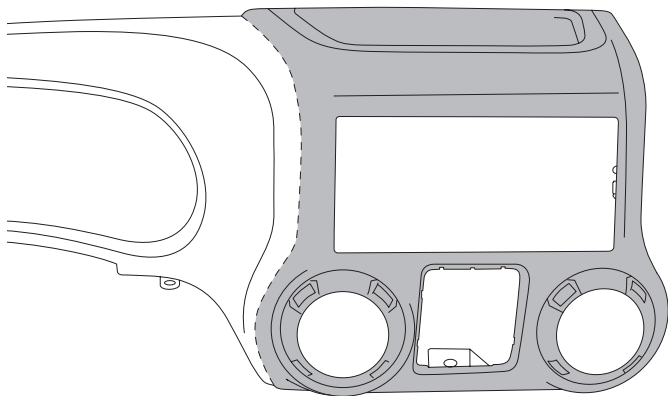

- 2** Remove the vents from the radio section on the OEM dash panel by pressing down on the lock tab and turning right. Mount vents on to the i209-WRA bezel.

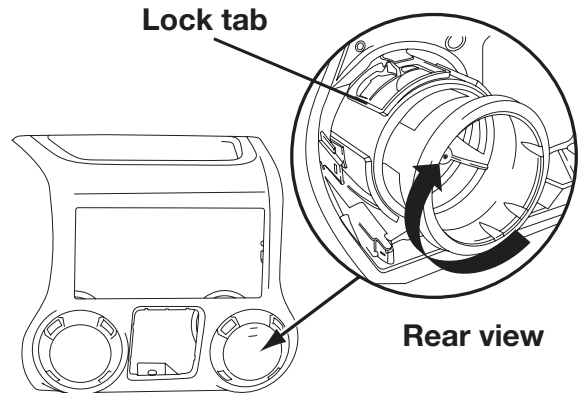

- 3** Use a cutting tool to trim the highlighted area shown below.

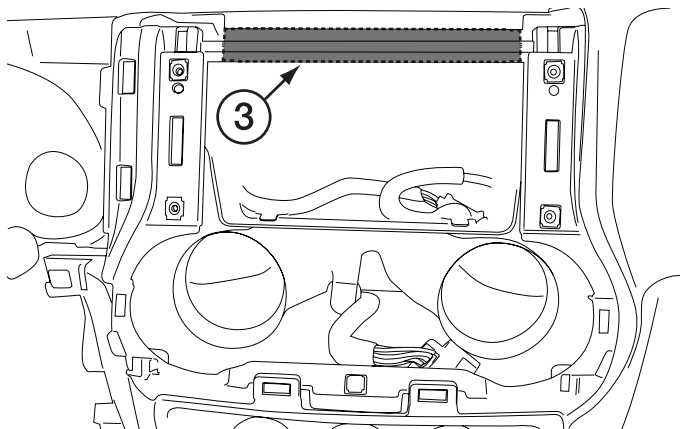

- 4** Mount the microphone as illustrated and run the cable to the radio cavity.

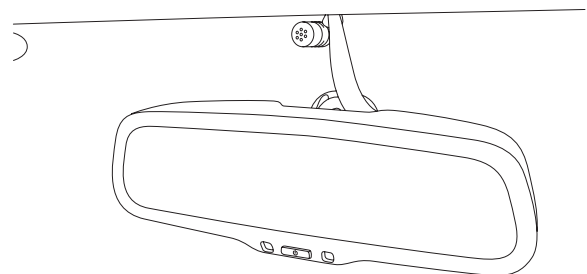

- 5** Plug the OBDII connector on to the OBDII port below the driver side dash and run the extension to the radio cavity.

⚠ Avoid any sharp edges or interfering with any safety equipment.

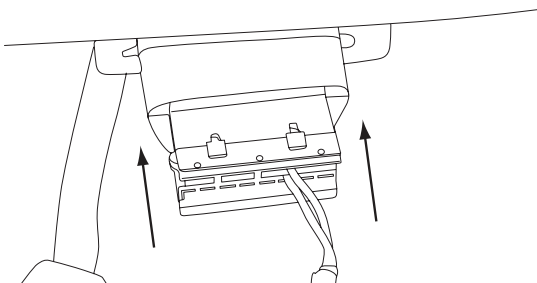

- 6** Attach the Maestro to the main harness.
 *See page 14 for more details.

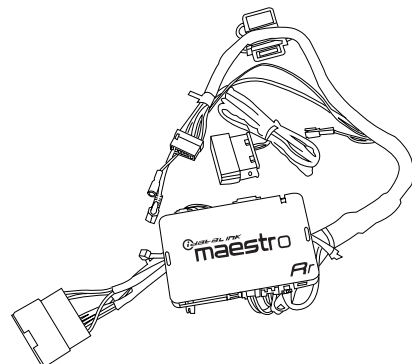

Installation Instructions

⚠ DISCONNECT THE BATTERY BEFORE CONTINUING. FAILURE TO DO SO WILL DISABLE MANY FEATURES.

- 1** Attach the modified panel using the factory screws.

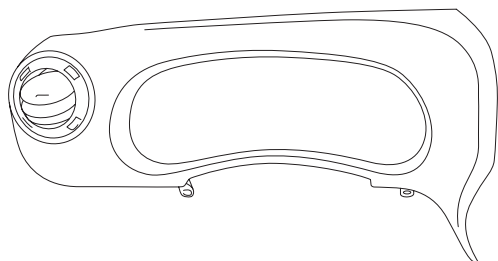

- 3** Apply Insulating pad by removing the paper backing. See diagram below.



- 5** Run the USB extension cable to an area you want to plug in at (typically the glove box or center console areas), connect the main harness and other adapters to the factory harness and secure them. To retain the factory USB port in uConnect systems, See page 11 for installation instructions.

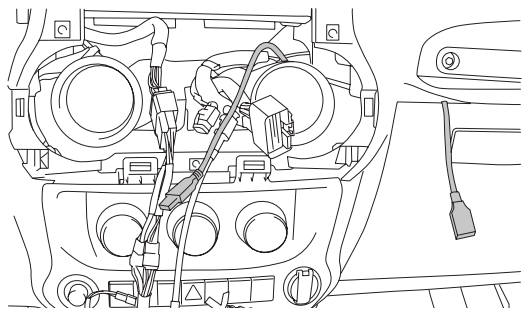

- 2** Put monitor face down on a soft, scratch free surface and attach Display Monitor Brackets using (4) 8mm screws (provided). Plug in the Display Cable and Display Power Harness.

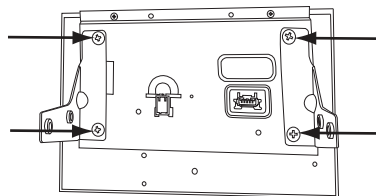

- 4** Attach the display and source unit with the 8mm screws (supplied) as shown below. Route the display cable and power harness from the display to the source unit and plug into the W. Remote and Display Out.

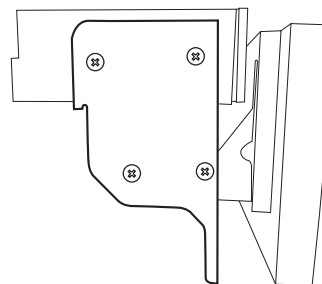

- 6** Route the key harness through the top-left side of the i209 source unit. Mount the i209 source unit using (4) 7mm factory screws.

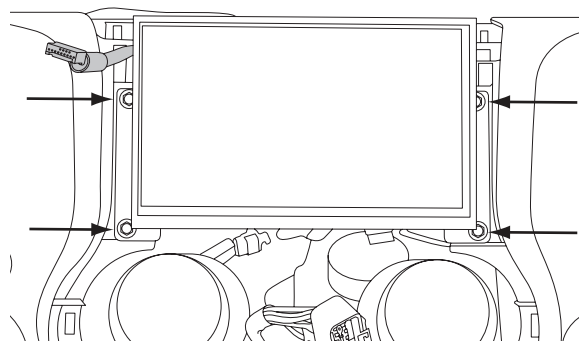

Connecting the Uconnect® USB port (only for vehicles with factory Uconnect®)

1 Remove the factory climate control panel. It is clipped on and can be removed with a panel removing tool. Extract the (2) 7mm bolts from Uconnect® module.

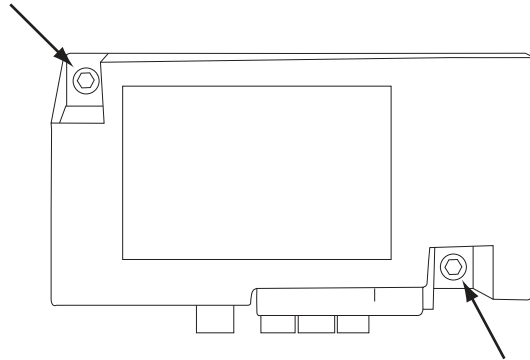

2 Disconnect the 24pin OEM connector.

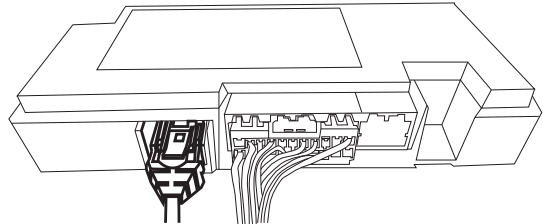

NOTE: Since the factory Uconnect® system is not going to be used you can unplug the 24 pin connector shown in step 2. If Uconnect® module is not disconnected the Uconnect® system will stay paired with previously paired phones. The user's phone may connect to both Bluetooth devices simultaneously resulting in unpredictable and potentially distracting behavior.

3 Secure the Uconnect® module to the original location using the 7mm bolts..

Connecting A SiriusXM Module (Sold Separately)

There is no way to integrate the factory SiriusXM tuner. Once the radio is removed, the factory SiriusXM is removed. As the title states, SiriusXM requires a tuner sold separately. This diagram shows how to integrate the antenna connection. For vehicles with factory SiriusXM connect the adapter to the factory SiriusXM antenna in the radio cavity. The factory SiriusXM antenna is located on the passenger side B-pillar. For vehicles without factory SiriusXM use the antenna that is included with the SXV300 SiriusXM Tuner.

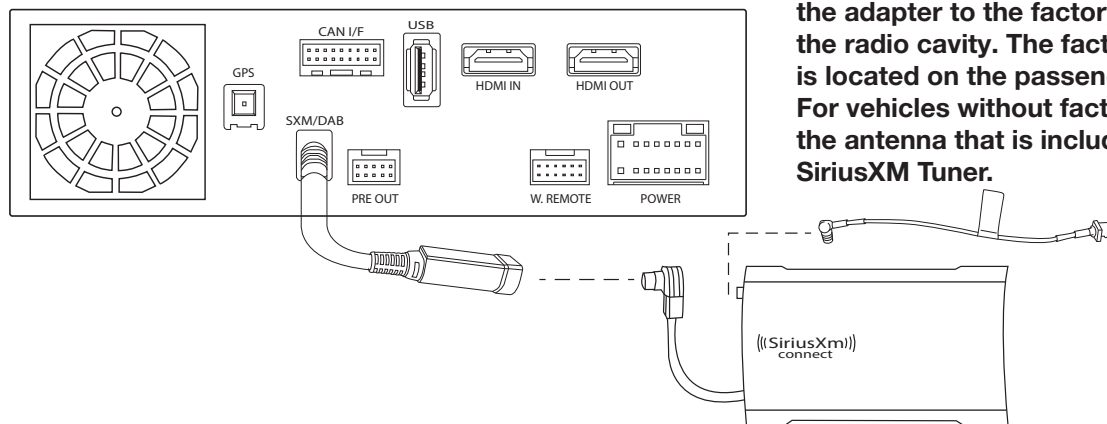

Mounting Brackets

⚠ DISCONNECT THE BATTERY BEFORE CONTINUING. FAILURE TO DO SO WILL DISABLE MANY FEATURES.

⚠ IMPORTANT: During the research and development of this product it was discovered that mounting tolerance may vary from the vehicle's trim level to year built. We have added a 1mm tolerance to the mounting brackets to compensate for such variance in mounting tolerance. Use the guides below as reference if there are any required adjustments.

Adjust the rear bracket as needed when the top or bottom is protruding or not flushed.

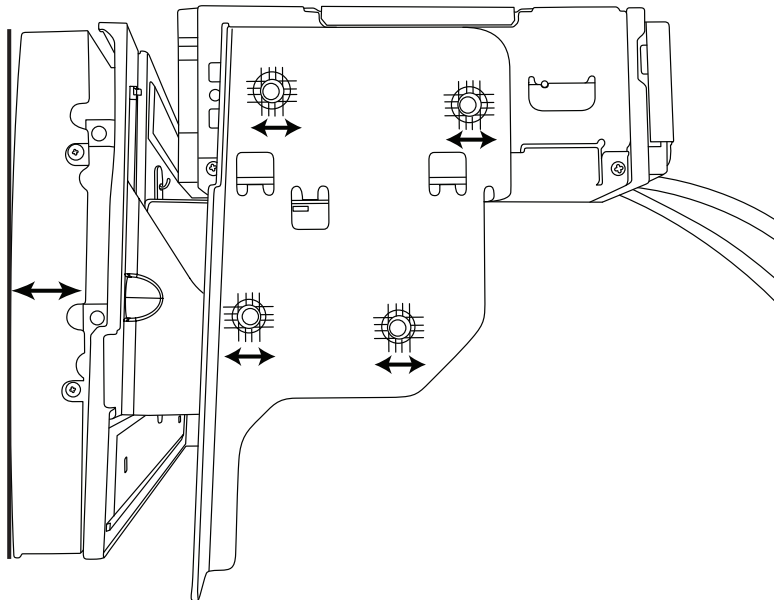

Adjust the side brackets as needed when either side is protruding or not flushed.

Exploded-View Diagram

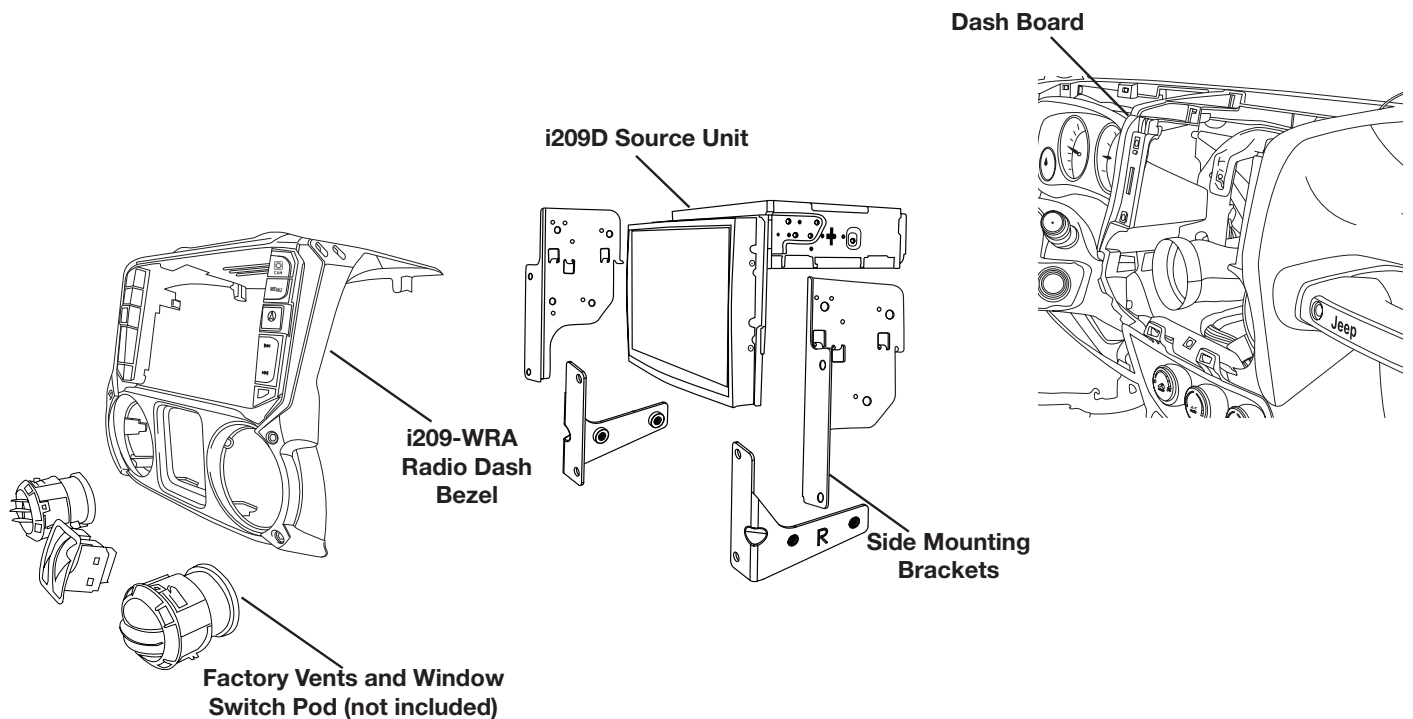

Bezel Wiring Diagram

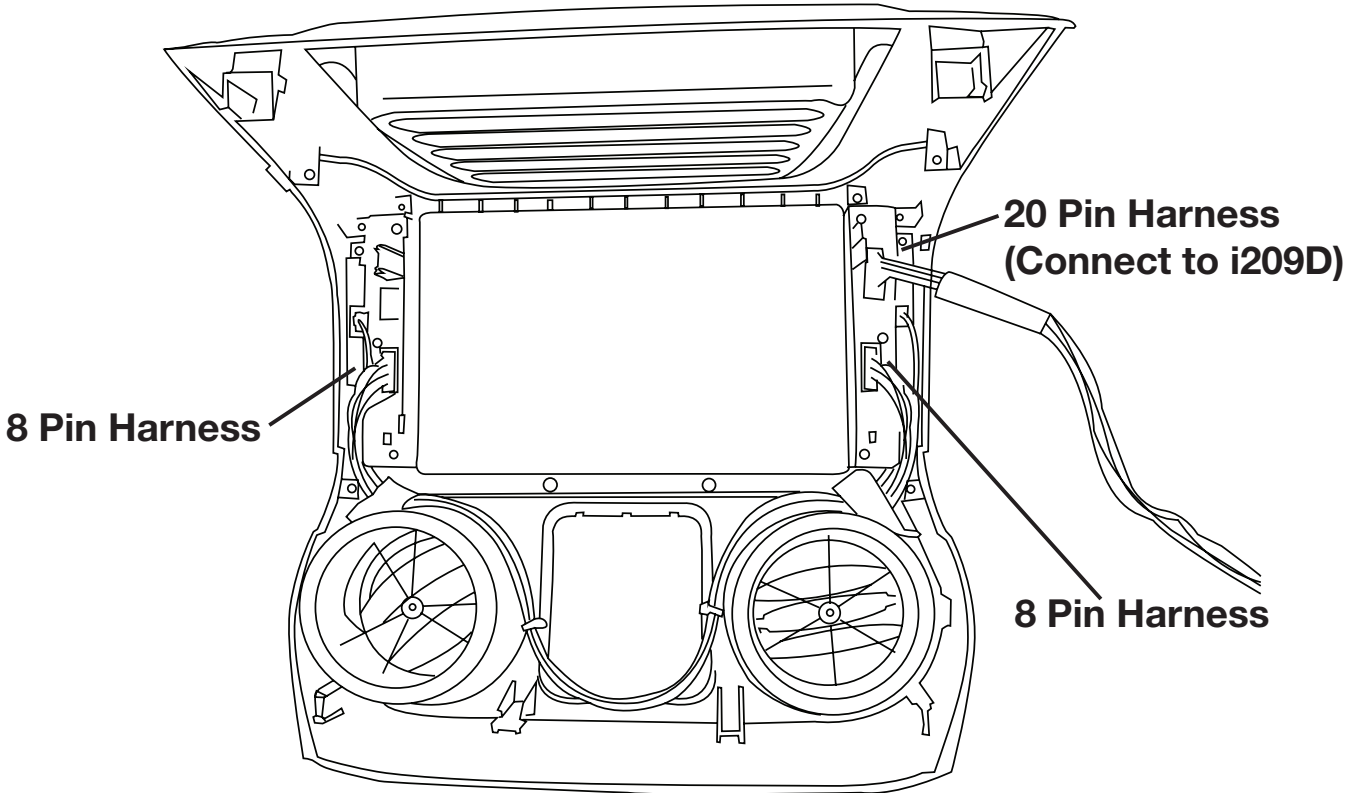

i209-WRA Wiring Diagram

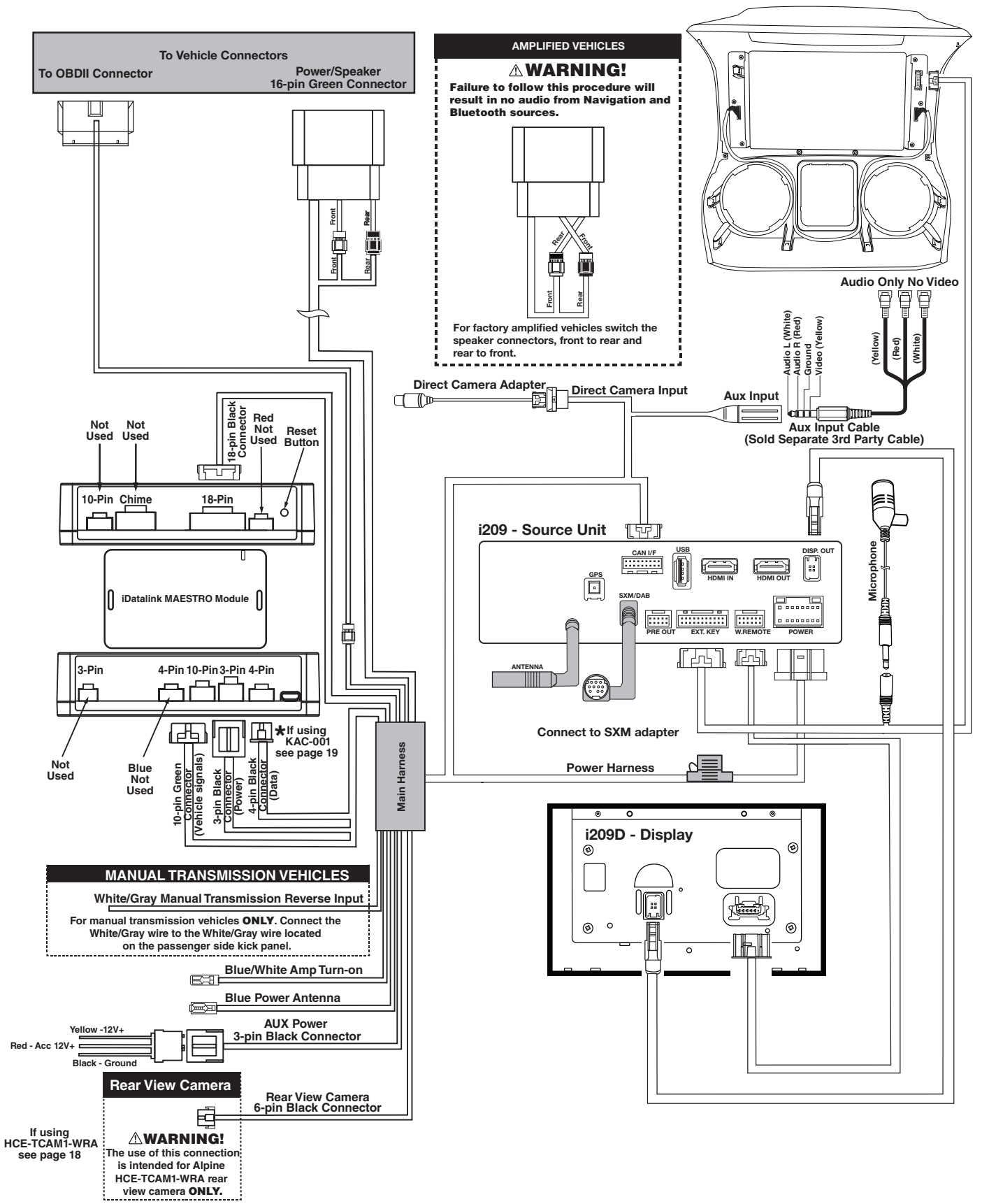

i209-WRA HDMI Usage With An iPhone

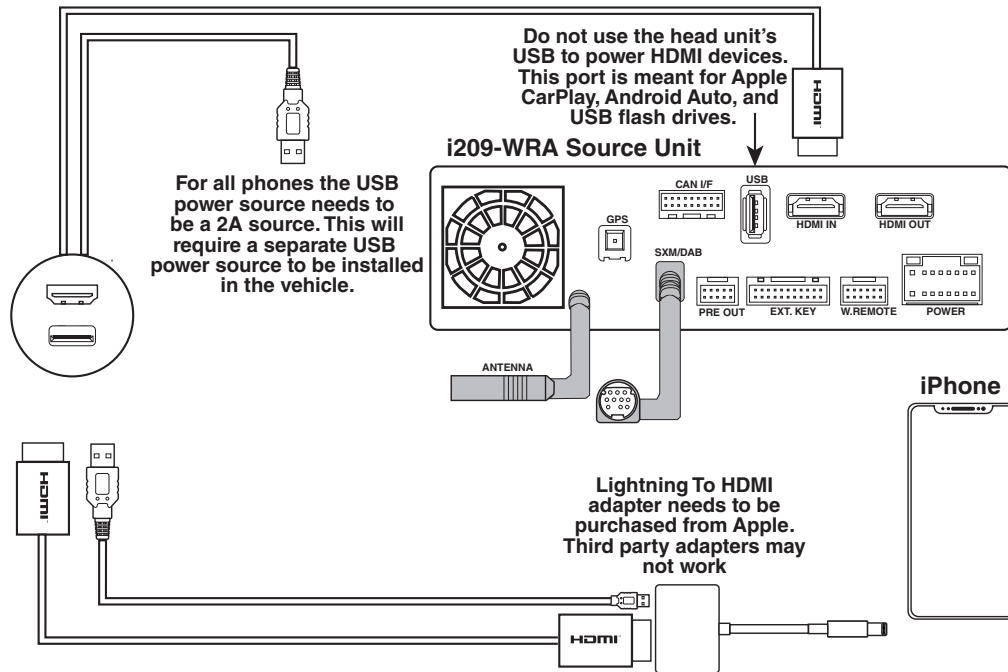

i209-WRA HDMI Usage With An Android Phone

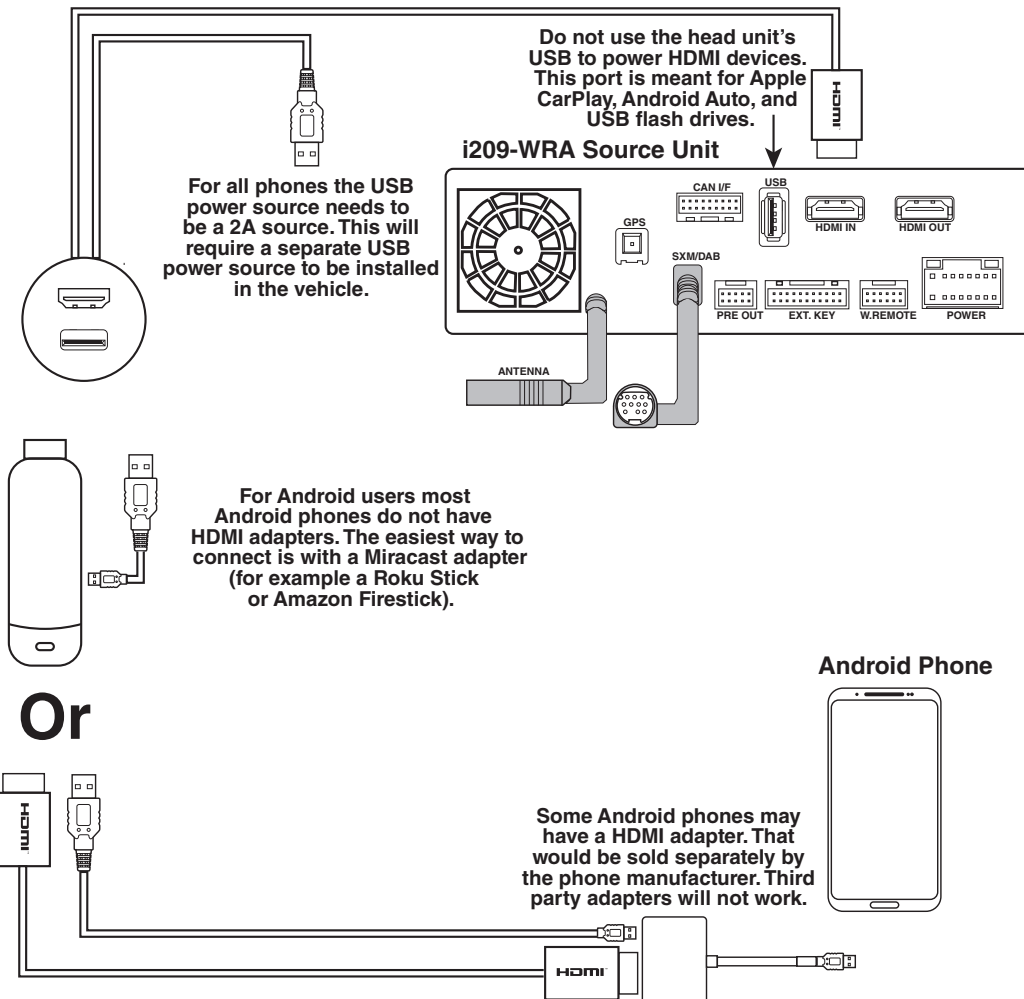

i209-WRA Wiring Diagram

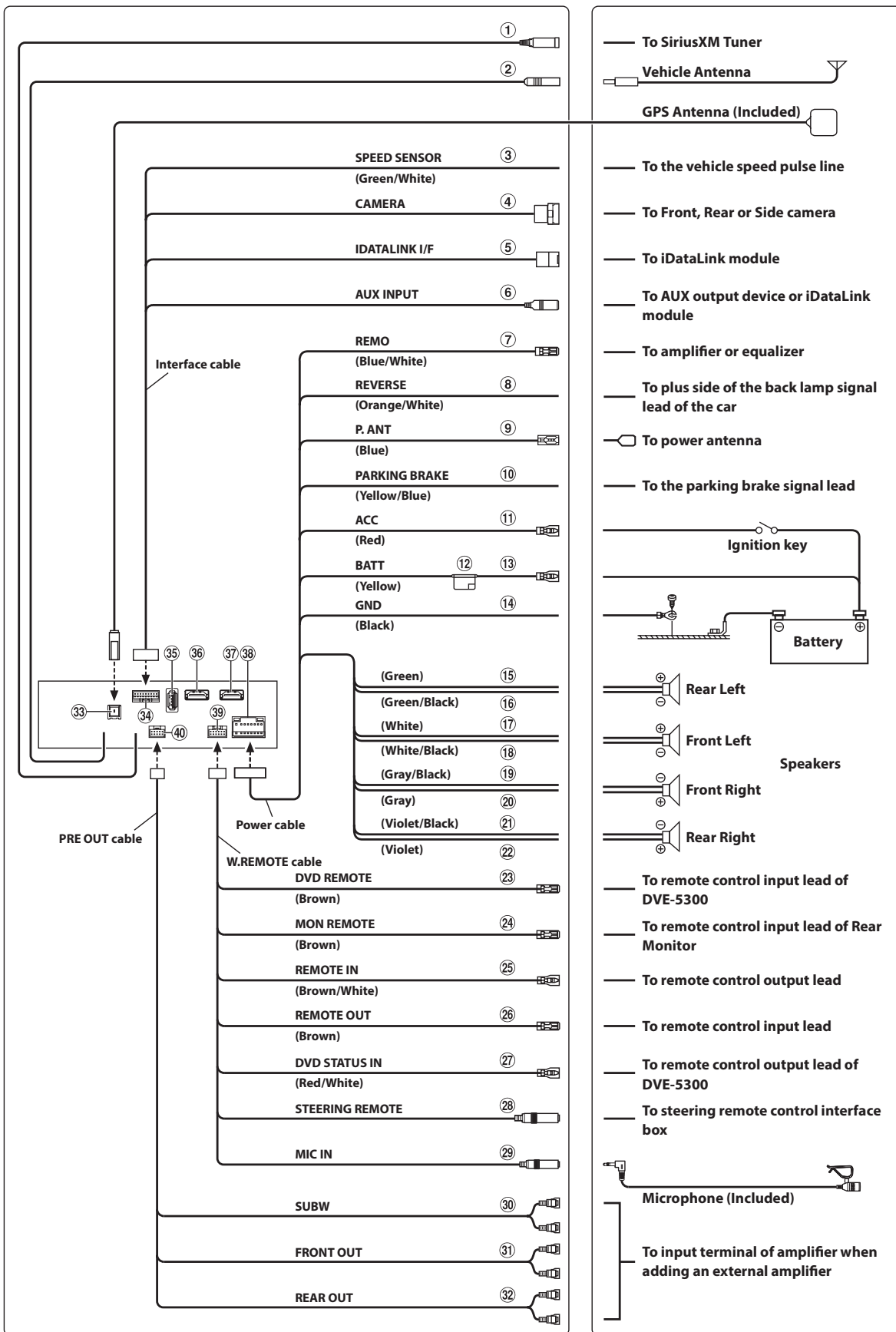

Wire Harness Pin Outs

Radio Main



Remote Harness

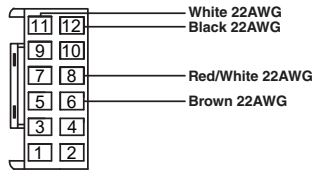

Cam Aux Data

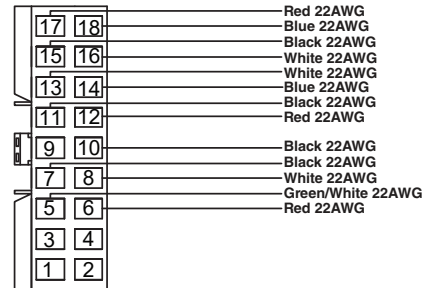

DVD Display

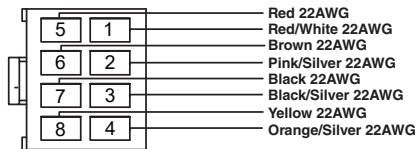

Key Harness



Rear Camera

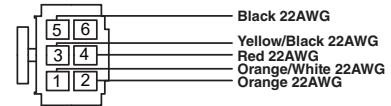

KAC-001 Power

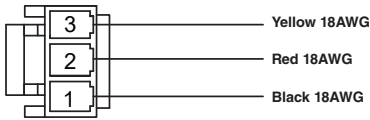

Direct Camera



Alternate Power

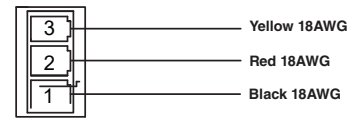

Data SWC

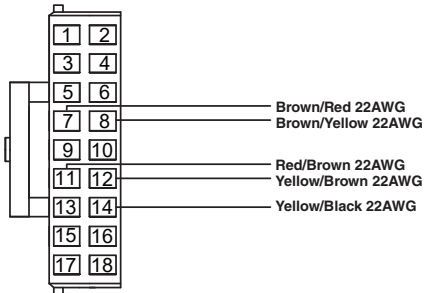

Radio I/O

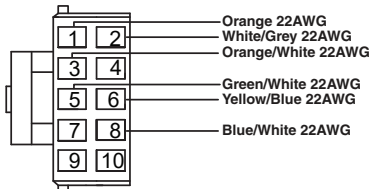

Power/ACC

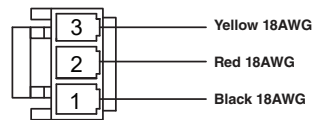

iDataLink



Audio In

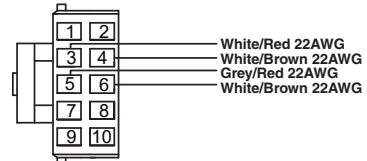

Wrangler Harness

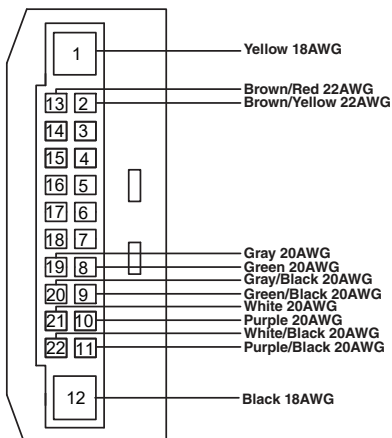

Wrangler Harness

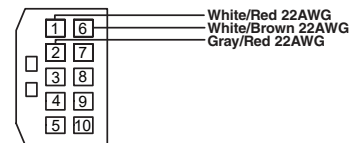

Speaker Harness

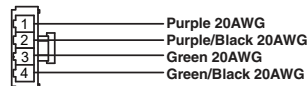

Speaker Harness



Connection Of HCE-TCAM1-WRA (Optional Accessory)

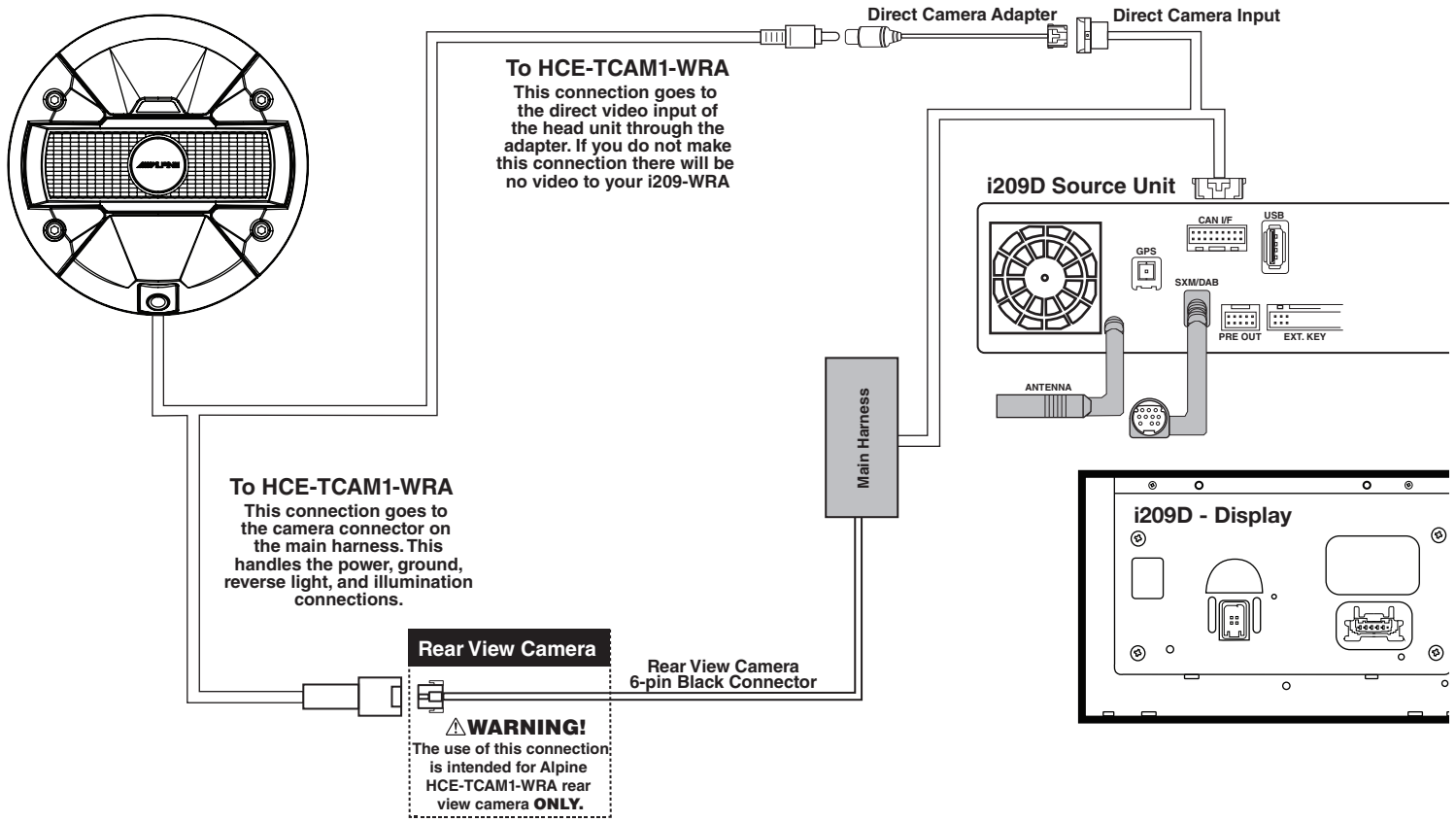

Connection Of An External Amplifier

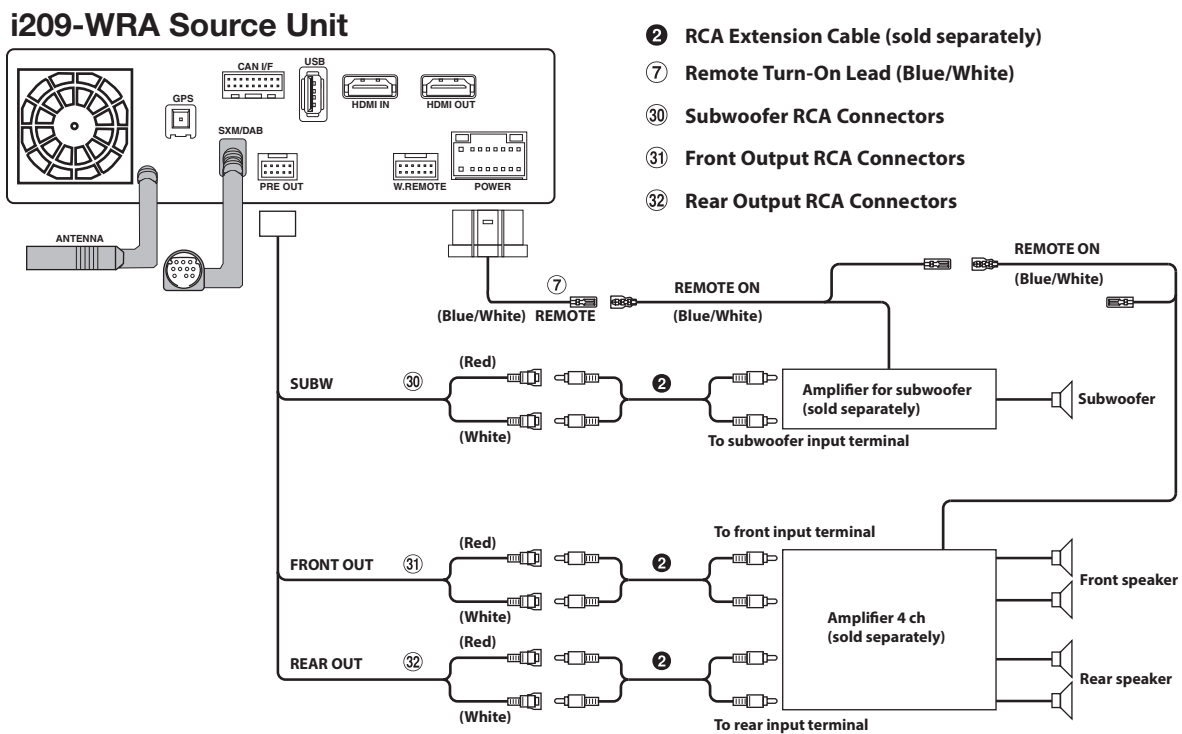

Connection Of KAC-001 (Optional Accessory)

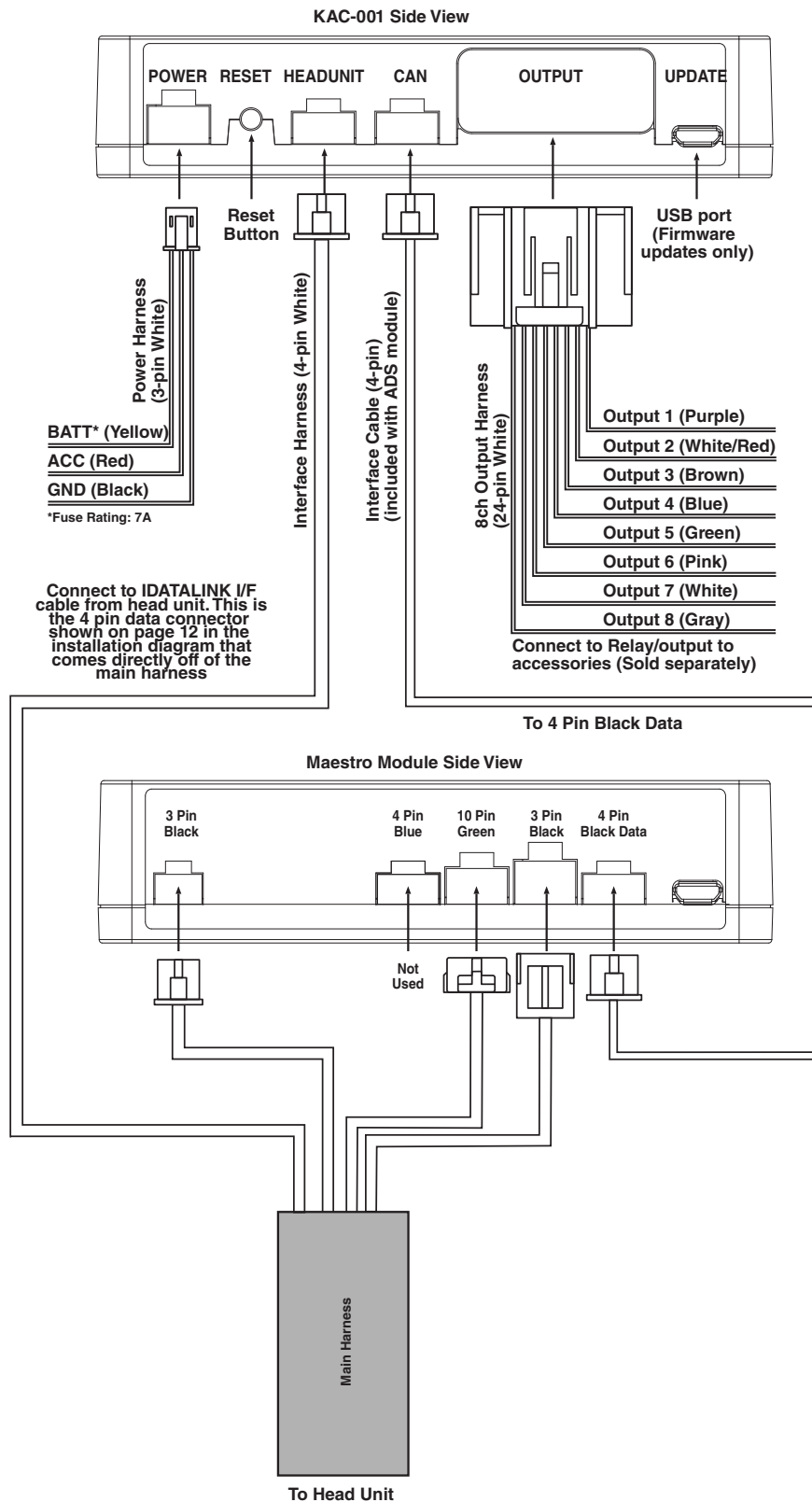

Steering Wheel Configuration

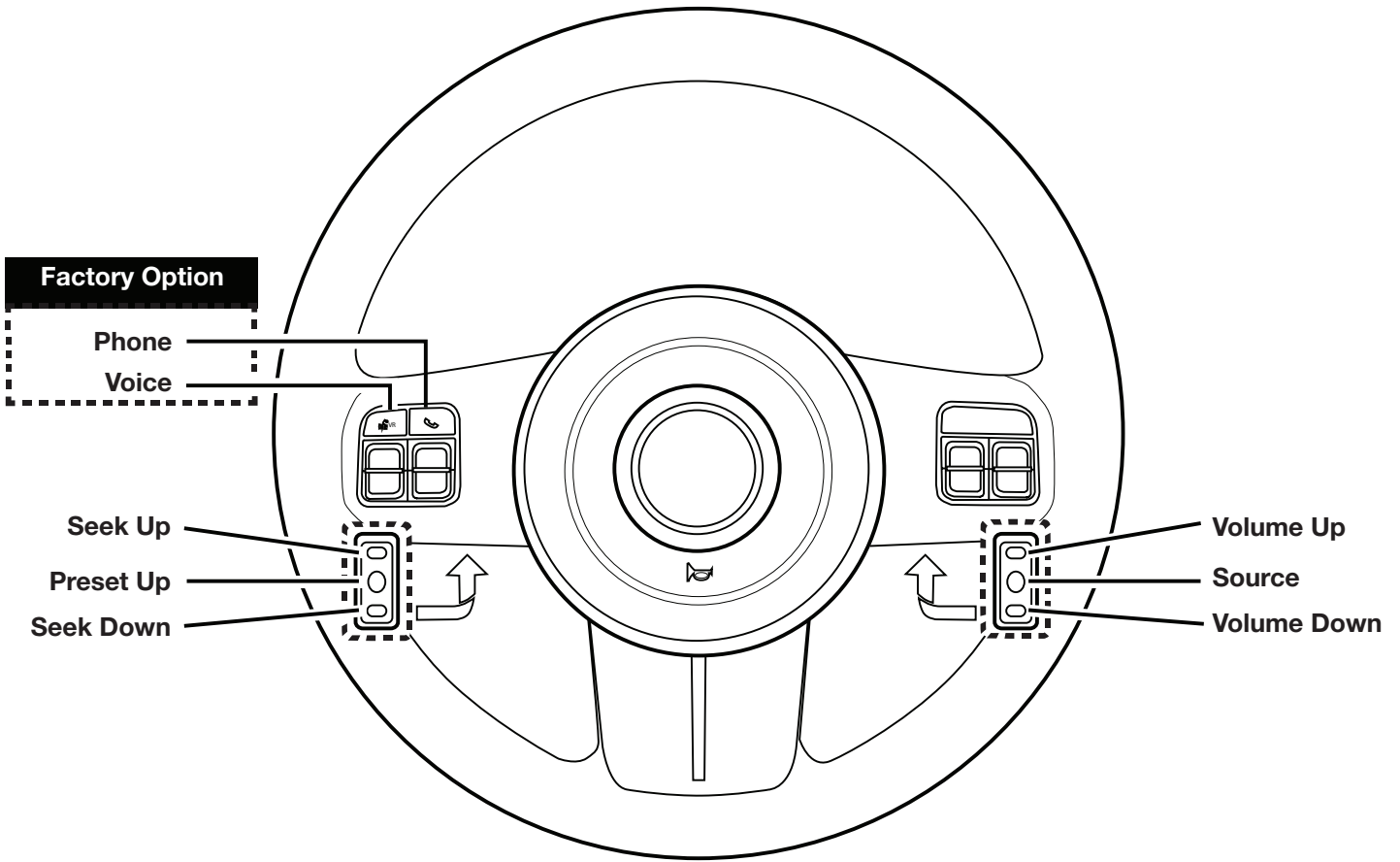

Button	Press Once	Press And Hold
Volume Up	Volume +	None
Volume Down	Volume -	None
Seek Up	Track +	None
Seek Down	Track -	None
Source	Source	Band
Next Preset	Preset & Folder +	Preset & Folder -
Voice	Voice Or Siri	None
Phone	Answer Call	Hang Up & Reject Call

Set Up Guide

- 1 Turn the vehicle's Ignition switch to ACC.
- 2 Turn ON the i209-WRA by pressing any key.
- 3 Select the user language and press OK.
- 4 Engage and release the parking brake twice.
- 5 If a camera is present, turn it ON in the system menu. (MENU/SETUP/SYSTEM/CAMERA/CAMERA SELECT).
- 6 AUDIO MUTE ON REVERSE- By default, when the vehicle is shifted into reverse the AUDIO will MUTE. If this feature is not desired turn it off in the AUDIO MENU (MENU/SETUP/SOUND/MUTE WHILE BACKING UP).
- 7 If the AUX Input is being use be sure to turn it ON in the SETUP MENU. (MENU/SETUP/SOURCE/AUX).
- 8 Set the DVD player (if optional DVD player is installed). (MENU/SETUP/SOURCE/HDMI).
- 9 When the KAC-001 (External Accessory Control Module) is present be sure to turn it ON in the SETUP MENU. (MENU/SYSTEM/EXTERNAL ACCESSORIES/EXTERNAL ACCESSORY CTRLR).
- 10 Vehicle information- Set the desired gauge information. (MENU/VEHICLE INFO/GAUGES/CAR SETTINGS).

Troubleshooting Guide

Symptom		Possible Cause	Remedy
1	iPhone not working with HDMI.	Not using Apple HDMI to Lightning adapter.	Purchase the HDMI to Lightning adapter directly from Apple. Not all 3rd party adapters work the same.
		Didn't plug USB power into a 2A source.	Do not plug into the USB from the Alpine head unit. A third party USB adapter will need to be used that is 2A.
2	Android phone is not working with HDMI.	Using incorrect HDMI adapter.	If the phone has the feature to use an HDMI adapter it must be the one purchased from the manufacturer of the phone, not a third party adapter.
		Miracast adapter isn't plugged into a 2A source.	Do not plug into the USB from the Alpine head unit. A third party USB adapter will need to be used that is 2A.
		Miracast adapter has resolution settings that are too high.	Plug the adapter into another monitor (for example a television in the home) and reduce the resolution settings.
3	iDatalink website says serial number is invalid.	Incorrect serial number is being used.	In the i207-WRA settings confirm the serial number. MENU/SETUP/GENERAL/ABOUT.
		Serial number may not be in iDatalink database.	Call ADS at 1-866-427-2999 and verify.
4	No output from RCA's	Maestro module is flashed for amplified system.	Re-flash module for non-amplified system.

Troubleshooting Guide Continued

Symptom		Possible Cause	Remedy
5	Headunit will not turn on.	Incorrect serial number was used when flashing maestro.	Flash Maestro with correct serial number.
		4 pin Maestro data cable is disconnected or damaged.	Check for proper connection or disconnected pins.
		OBD2 cable is not plugged in.	Connect OBD2 connector to the OBD2 port.
		Monitor or main harness are not connected.	Check for proper connection or disconnected pins.
6	Cannot enter SETTINGS MENU.	Vehicle is in motion or parking brake is not engaged.	With vehicle in (P)PARK engage the parking brake. Release the parking brake and engage the parking brake a second time, as shown in the Setup Guide on page 21.
8	Sound mutes when vehicle is shifted into reverse.	Mute on reverse is turned on in the SOUND menu.	Change Mute on reverse to off.
9	Only the front speakers are on for SXM Radio.	SXM Tuner has not been activated.	Activate SXM Tuner.
10	The vehicle is incorrectly positioned on the Navigation display.	Poor GPS signal.	Ensure the recommended GPS antenna route was used. See page 7.
11	CarPlay, Android Auto, or off-road navigation map positioning issues.	GPS antenna is positioned incorrectly.	GPS antenna is obstructed and doesn't have line of sight to the sky. Perform a factory reset. The unit will automatically recalibrate.
12	CarPlay, Android Auto, or off-road navigation vehicle position icon heading in wrong direction	Reverse Signal is not connected or not reliable.	Ensure that Reverse wire is connected. Also ensure that no 3rd party interface module(s) interfere with the Reverse Signal. The head unit uses the Reverse Signal to achieve optimal positioning performance.
13	iPhone or Android phone is not recognized when connected to the USB cable.	Loose or disconnected USB cable.	Check the USB connection behind the headunit.
		Non-compatible cable.	Use the cable supplied with the iPhone or Android phone and only plug into the extension provided with the head unit. Third party adapters and long extensions may not work. Only use USB extension that came with the head unit.
		Dirty charging port on phone.	Clean charging port.
14	Volume controls on bezel and steering wheel controls do not work.	The setting for External Processor was turned on.	That setting should only be checked when using an external sound processor. When there isn't one being used in the audio system it needs to be in the default setting of off. MENU/SETUP/SYSTEM/EXTERNAL ACCESSORIES/EXTERNAL AUDIO PROCESSOR/OFF
15	Video not working with Aux Input.	The Aux Input is only meant for audio.	There is no way for the video portion to be active.