

FLAT HIGH TOP FLARE SET

INSTALLATION MANUAL

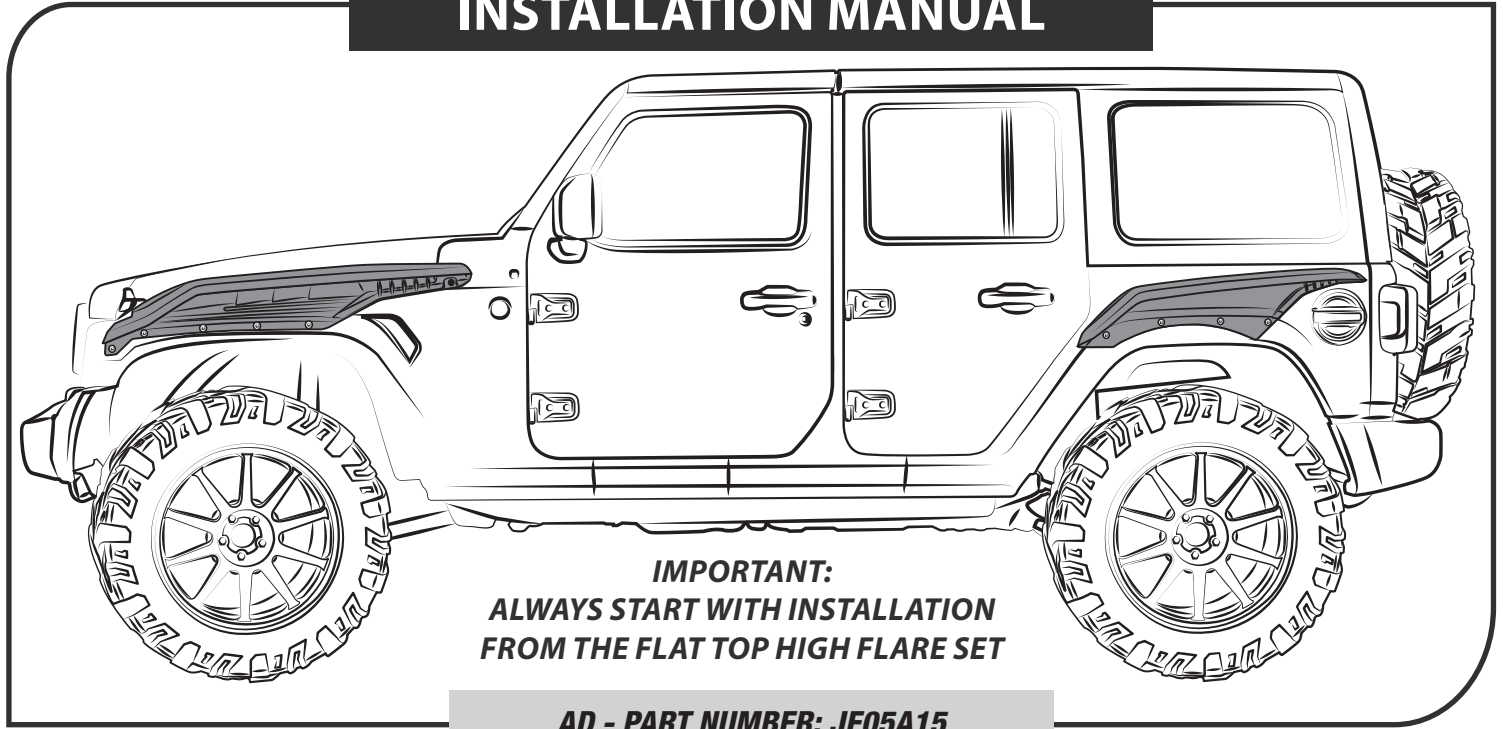

IMPORTANT:
ALWAYS START WITH INSTALLATION
FROM THE FLAT TOP HIGH FLARE SET

AD - PART NUMBER: JE05A15

**READ CAREFULLY
BEFORE INSTALLATION**



**WASH BEFORE
INSTALLING**

**WE RECOMMEND
2 PERSONS FOR
INSTALLATION**

AFTER INSTALLING
DO NOT WASH CAR



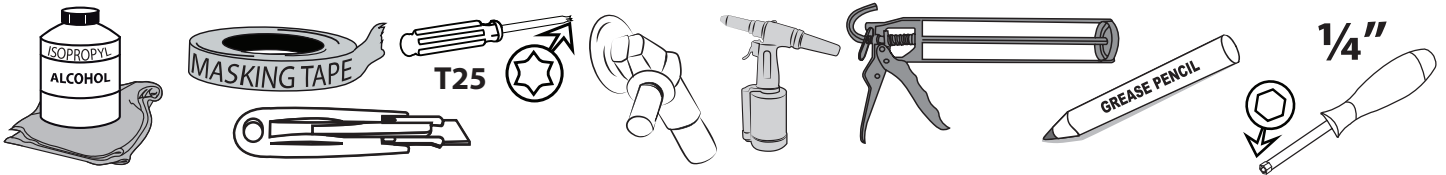



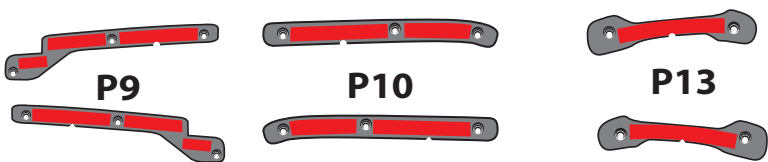
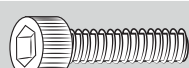

24 hrs

TOOLS



CHECK LIST

*ALREADY INSTALLED ON THE PART

ITEM	DESCRIPTION	DRAWING	AMOUNT
A	*VHB TAPE		N/A
B	BRACKETS LH P9 BRACKETS RH P10		3 SETS
C	STAINLESS STEEL CYLINDRICAL HEAD ALLEN SCREW 8 x 30 mm		2 PCS
D	STAINLESS STEEL FLAT WASHER 5/16"		2 PCS
E	STAINLESS AIR DESIGN SUPER BOLT 6 x 20 mm		18 PCS
F	THREADLOCKER		1 PC
G	JACK NUTS 6 x 16 mm		4 PCS
H	ADHESION PROMOTER		2 PC
I	POLYURETHANE ADHESIVE 310 ml		1 PC
J	INSTALLER WRENCH		1 PC



The ideal temperature range of the part and the vehicle when installing must be 16°C (60°F) to 40°C (104°F), this guarantees a correct assembly.

FRONT FLAT HIGH TOP FLARE

1 CUT THE OEM BRACKETS

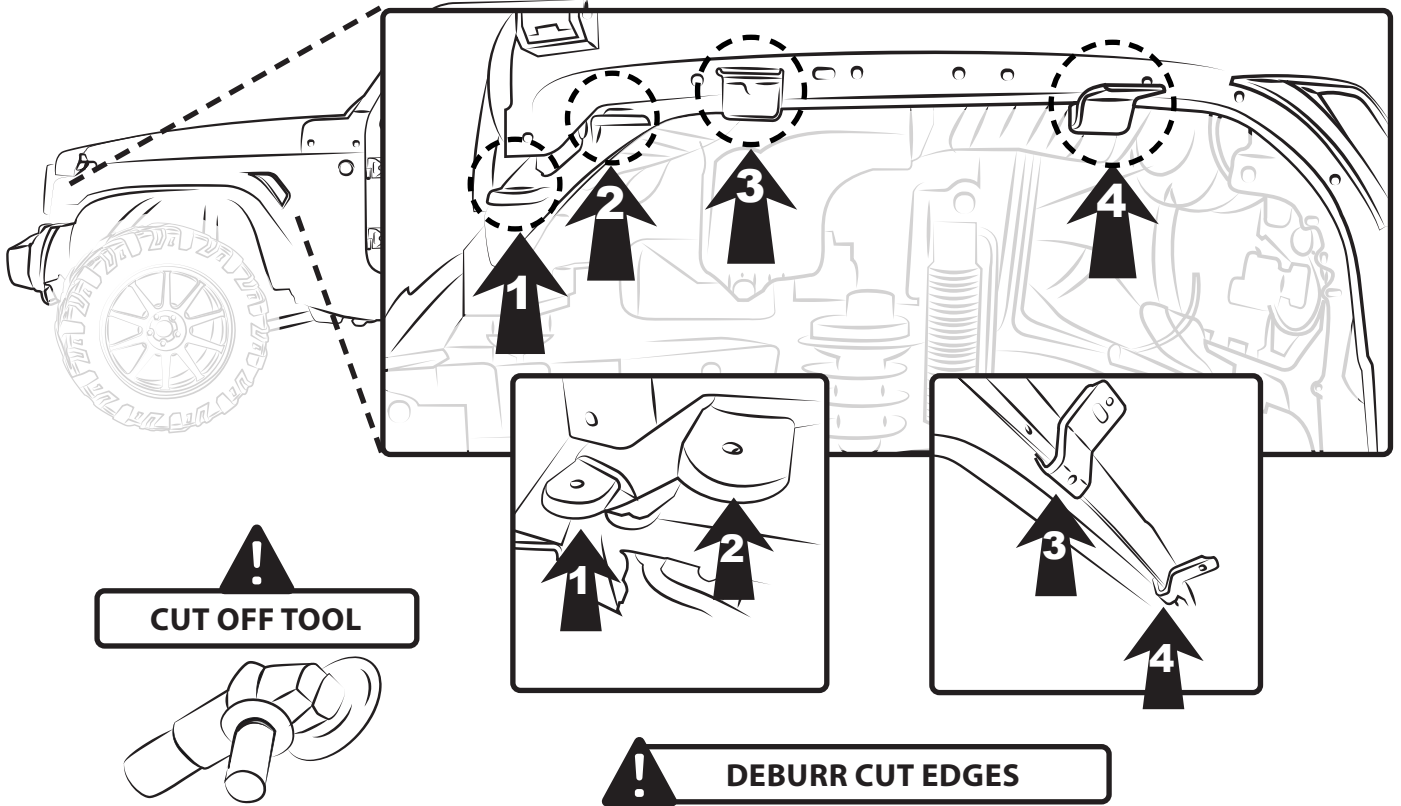

**OUTLINE WITH MASKING TAPE AND
APPLY CORROSION PROTECTOR**

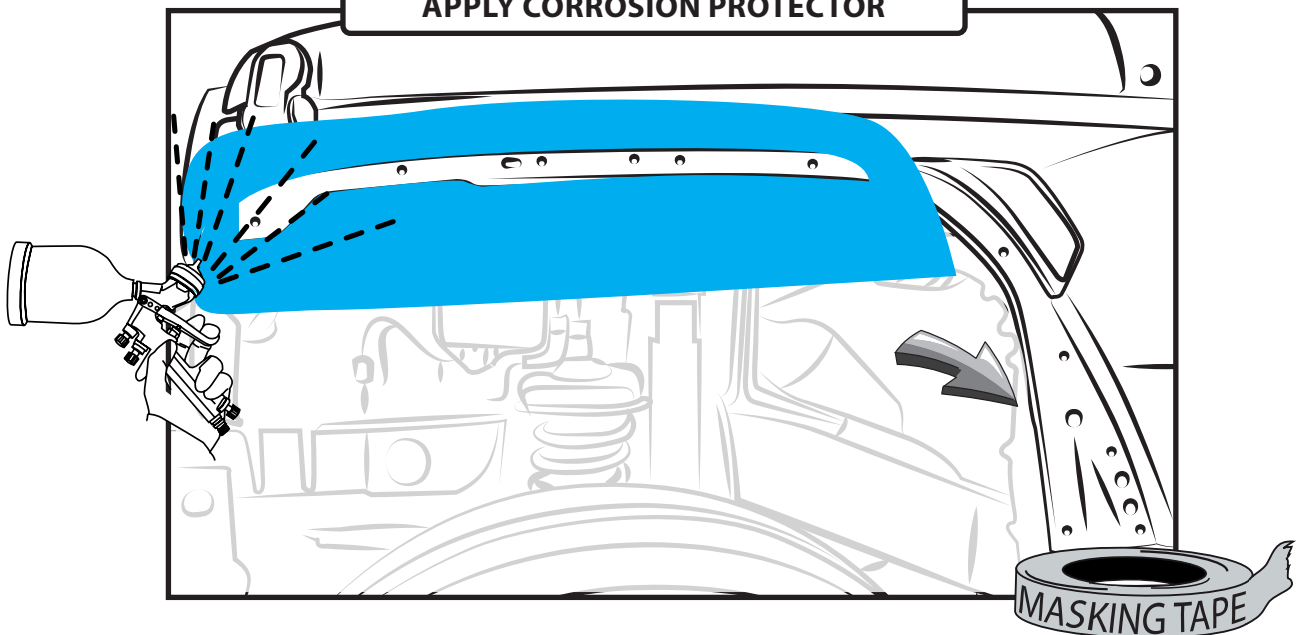

**REMOVE THE
MASKING TAPE**

FLAT HIGH TOP FLARE SET - WRANGLER JL 2018+ INSTALLATION MANUAL

2 CLEAN THE FENDER INNER ZONE

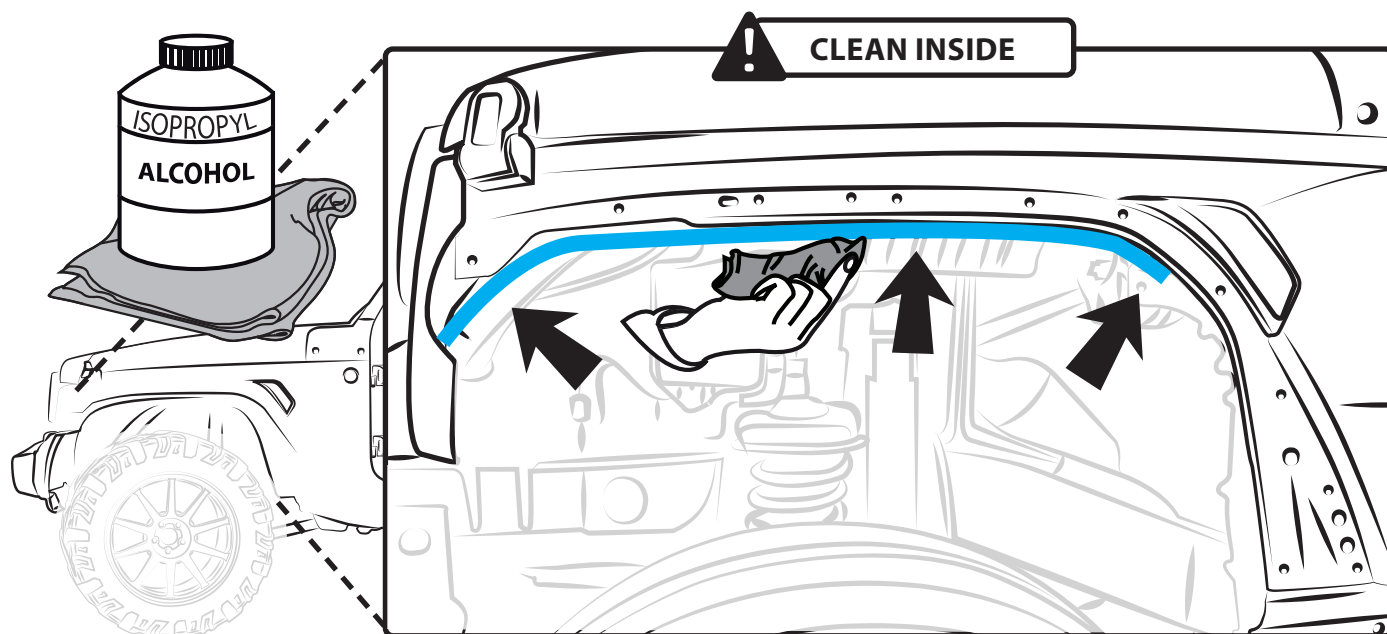

3 APPLY ADHESION PROMOTER ON THE FENDER INNER ZONE

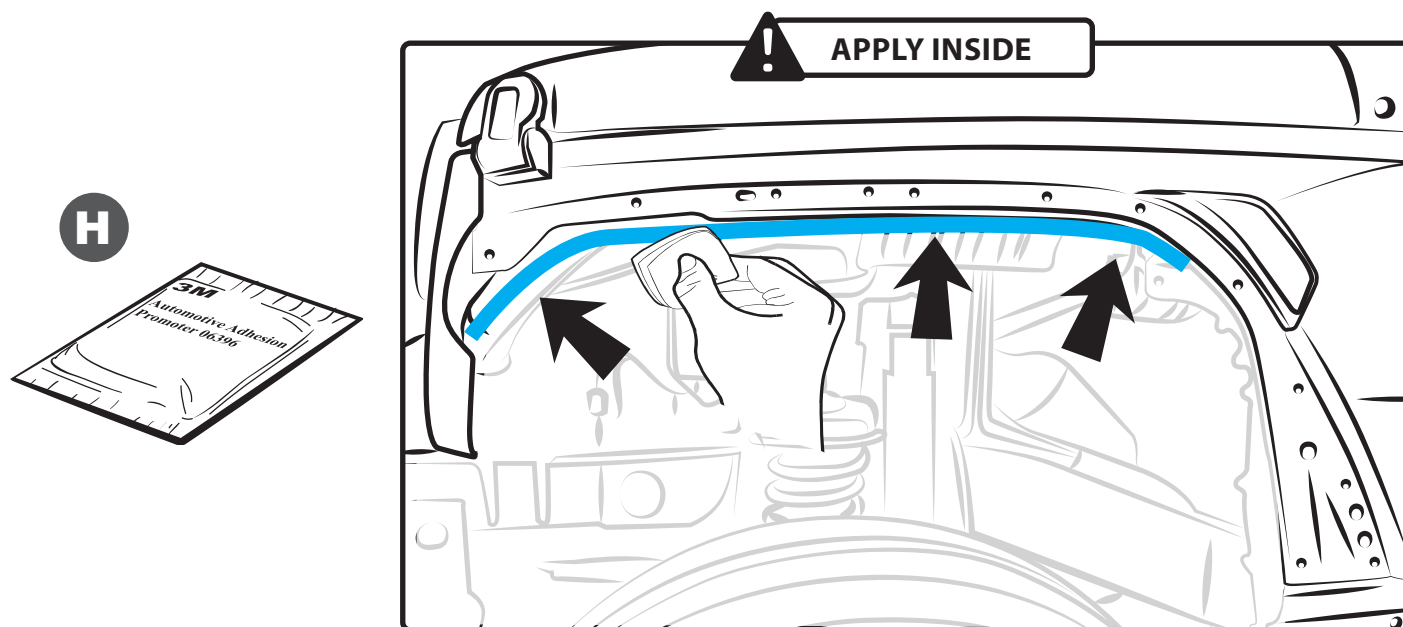

4 PEEL THE BRACKETS

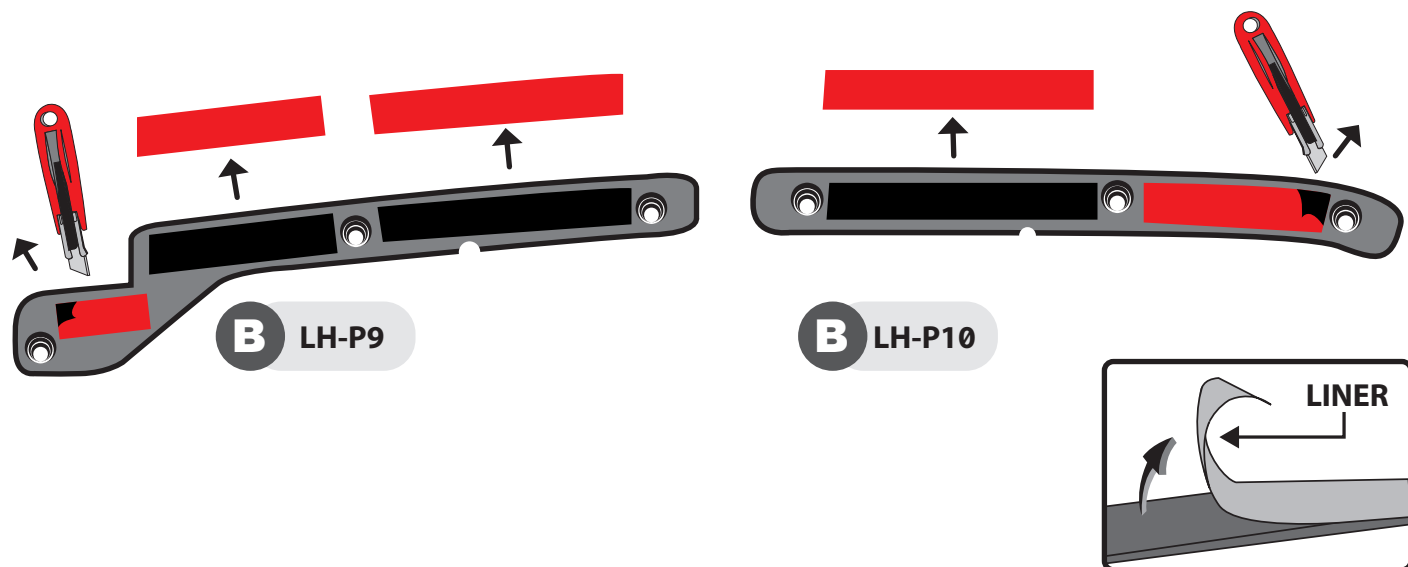

5 PLACE THE BRACKETS

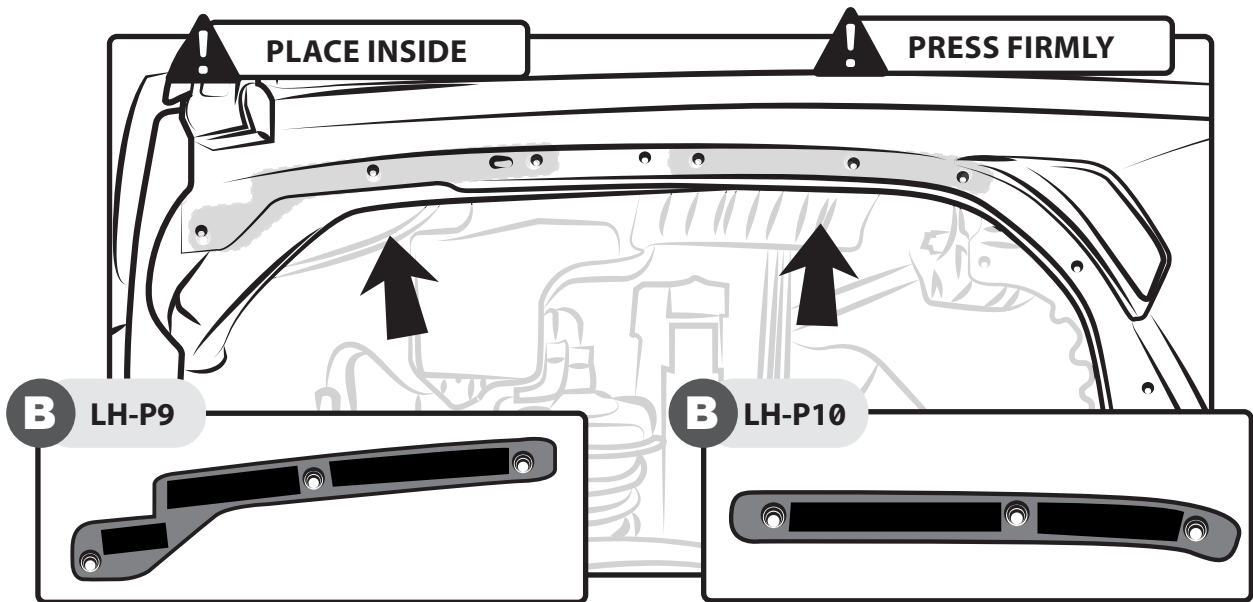

6 REMOVE THE FACTORY FASTENER

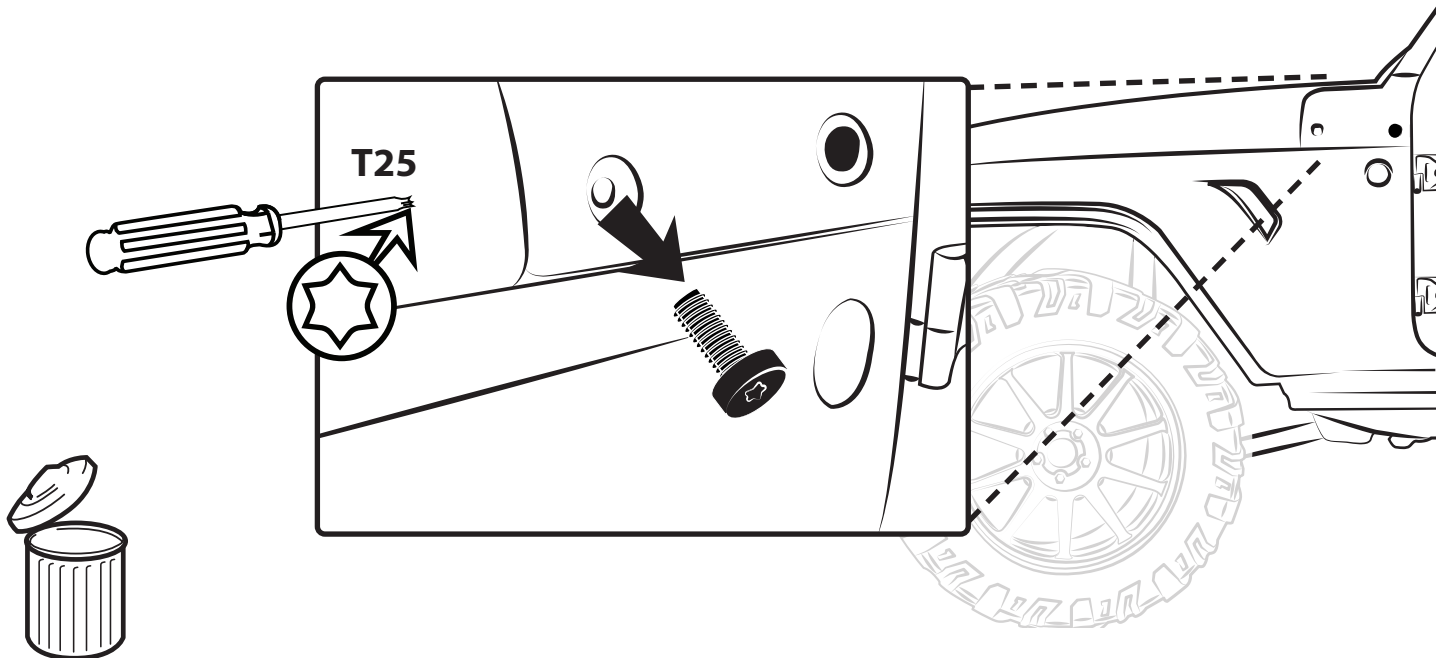

7 CLEAN THE INSTALLATION ZONE

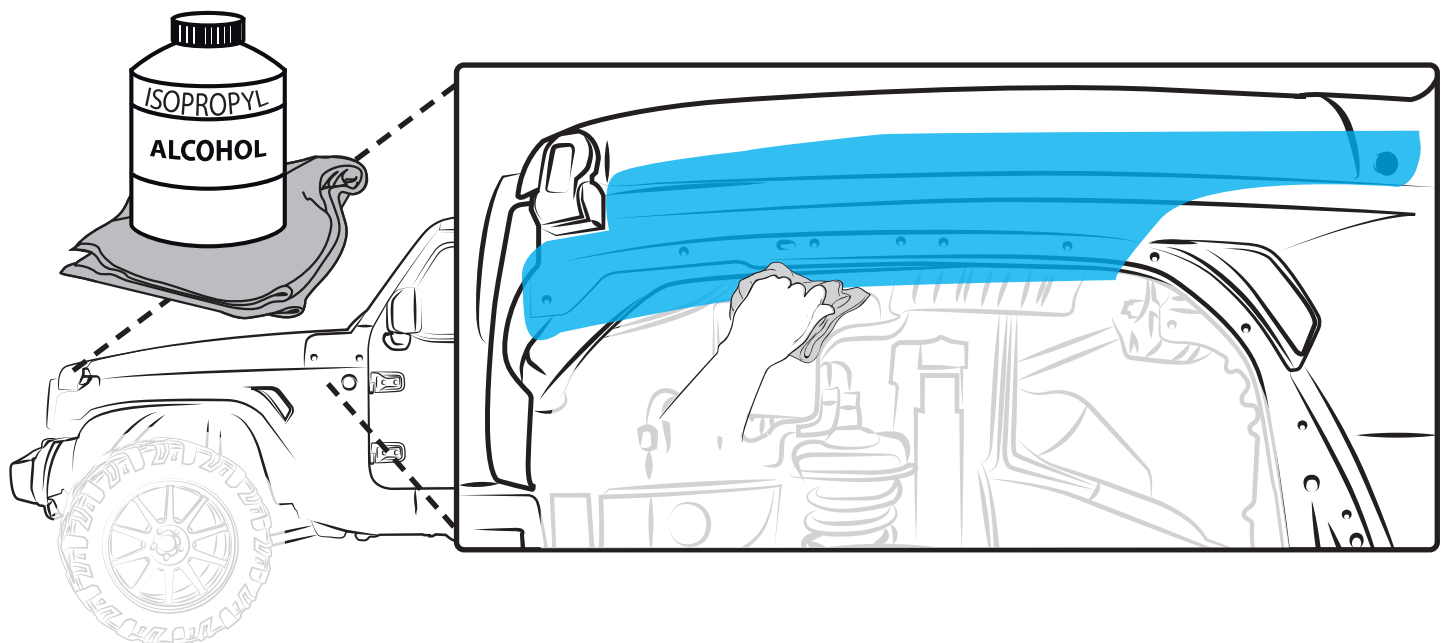

FLAT HIGH TOP FLARE SET - WRANGLER JL 2018+ INSTALLATION MANUAL

8 TEST FIT THE TOP FLARE

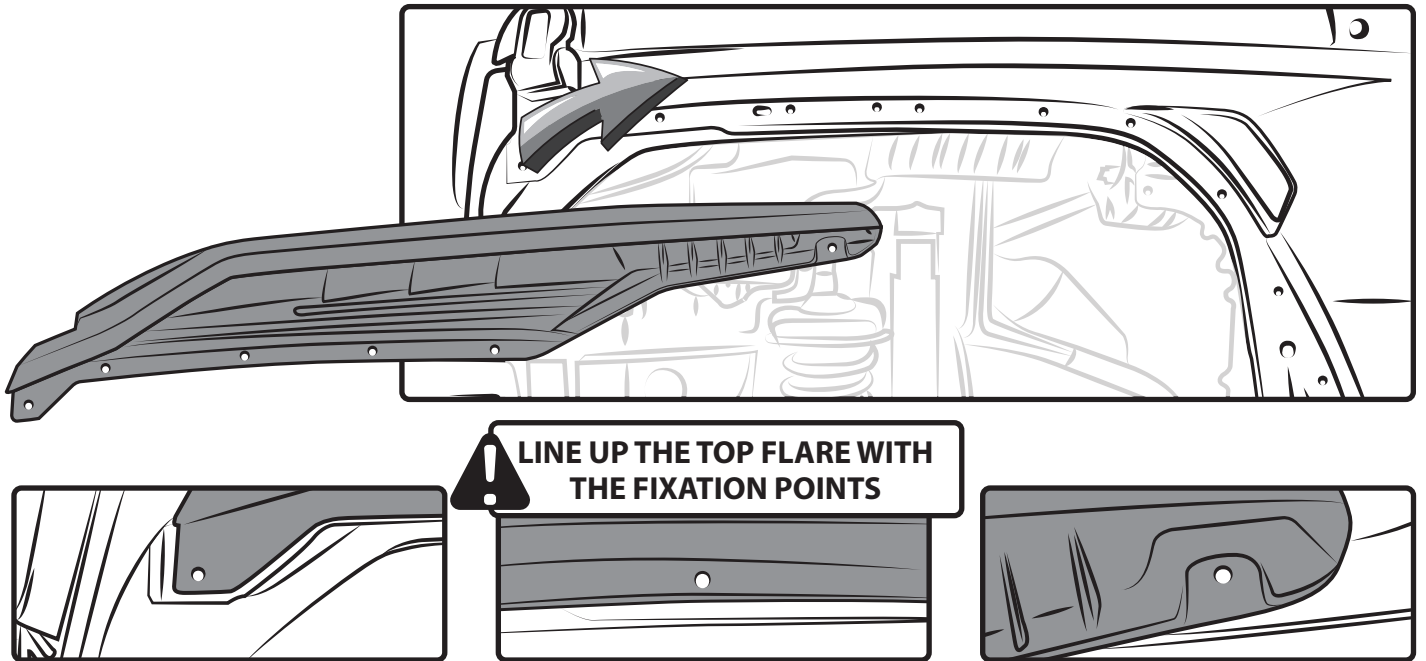

9 MARK AS SHOWN

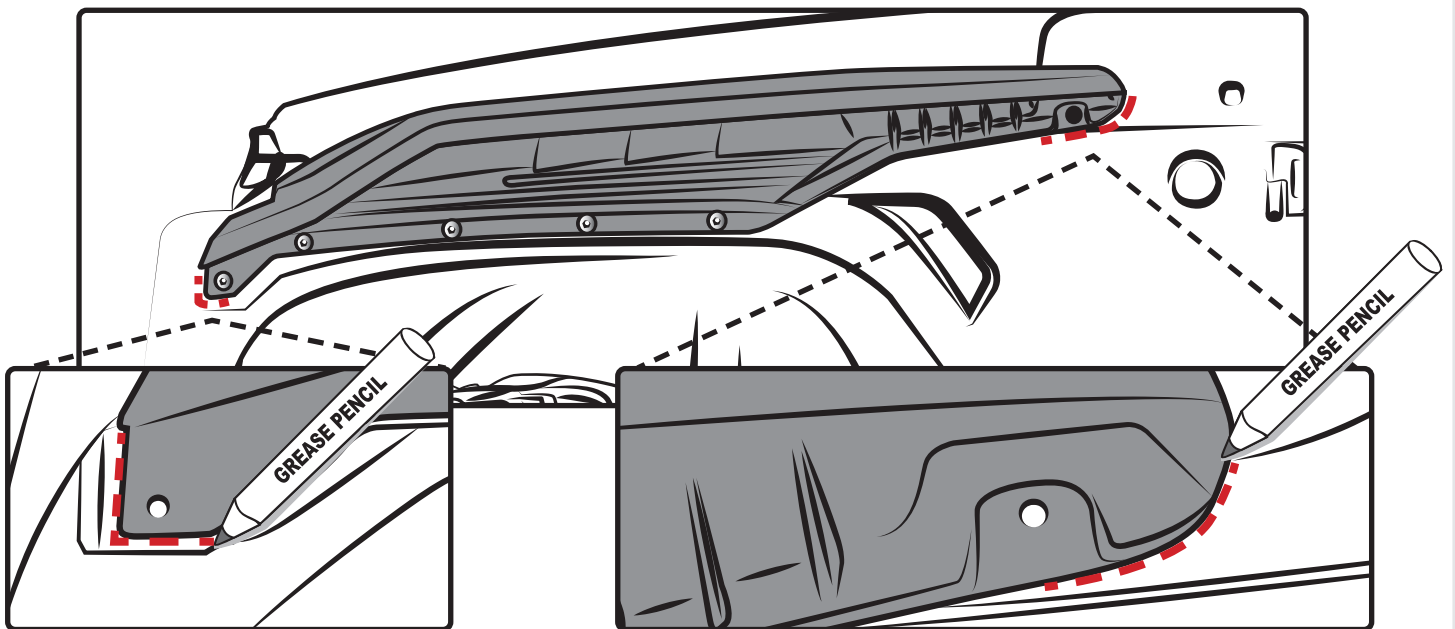

10 REMOVE THE TOP FLARE

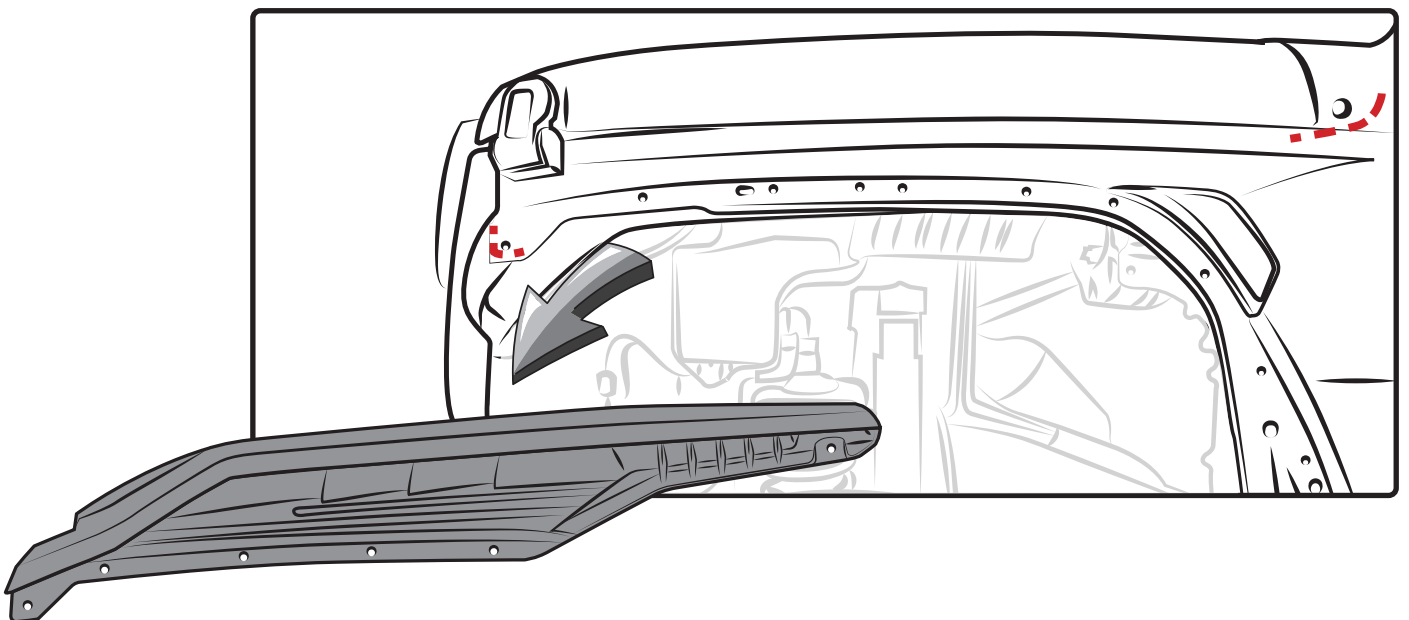

11 CLEAN THE ADHESIVE CHANNEL

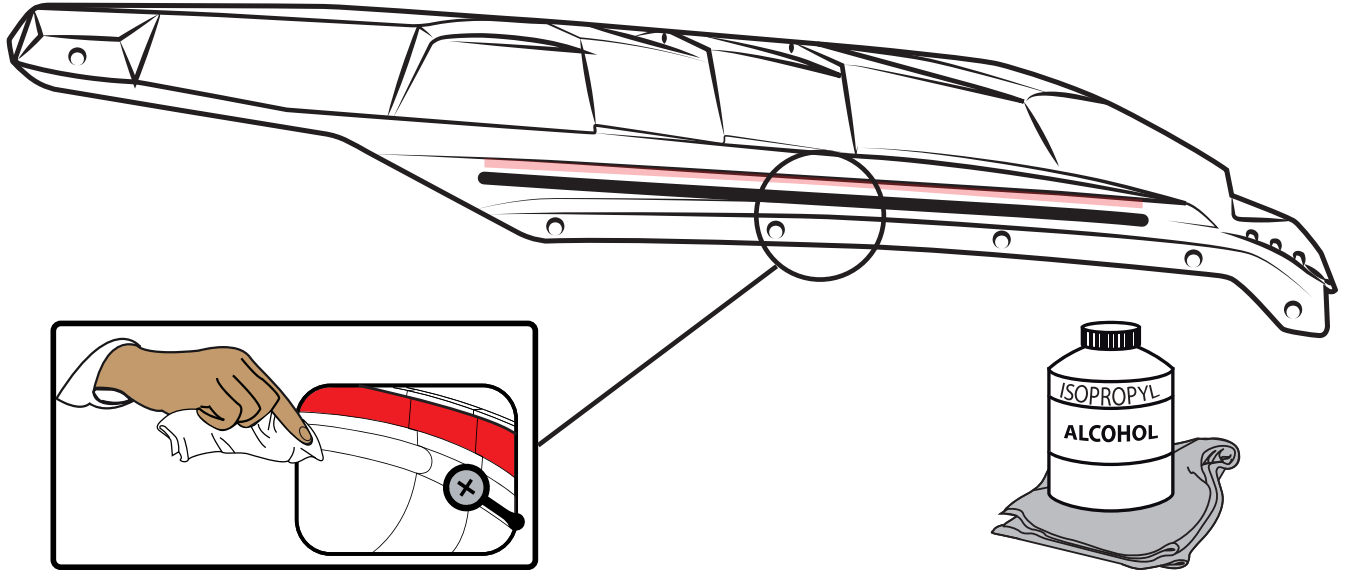

13 APPLY POLYURETHANE ADHESIVE

!
POLYURETHANE
ADHESIVE MUST
NEVER TOUCH THE
DOUBLE SIDED TAPE

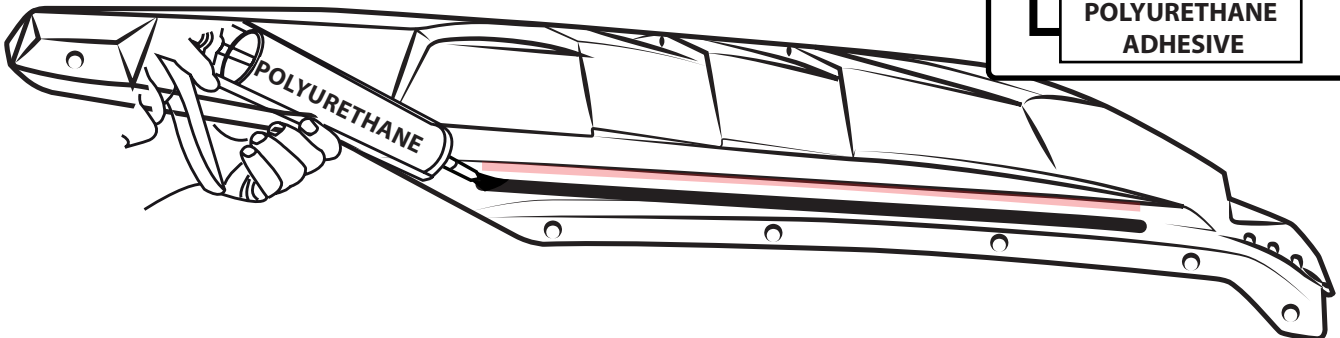
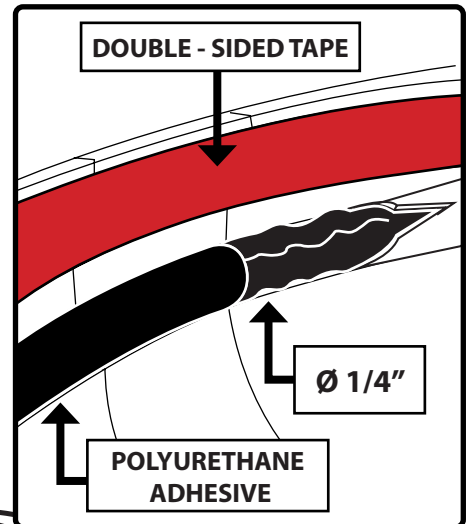
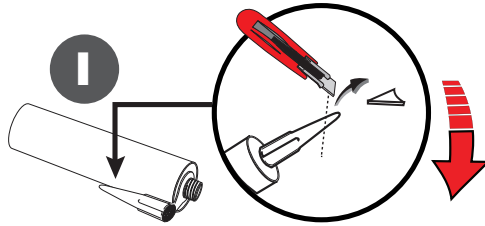

12 PEEL THE LINER LEADS

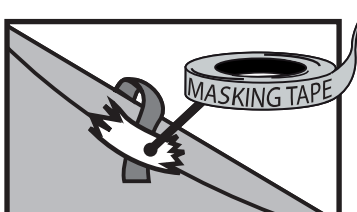
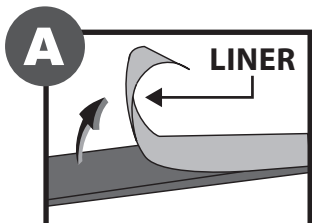
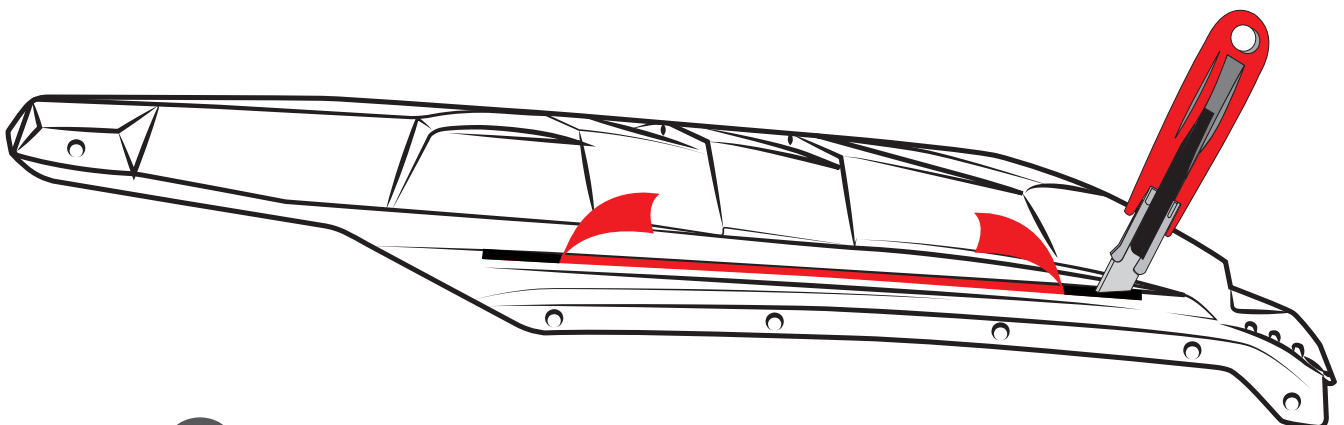

!
STICK THE LINER
LEAD ON THE
OUTSIDE

FLAT HIGH TOP FLARE SET - WRANGLER JL 2018+ INSTALLATION MANUAL

14 PLACE THE TOP FLARE

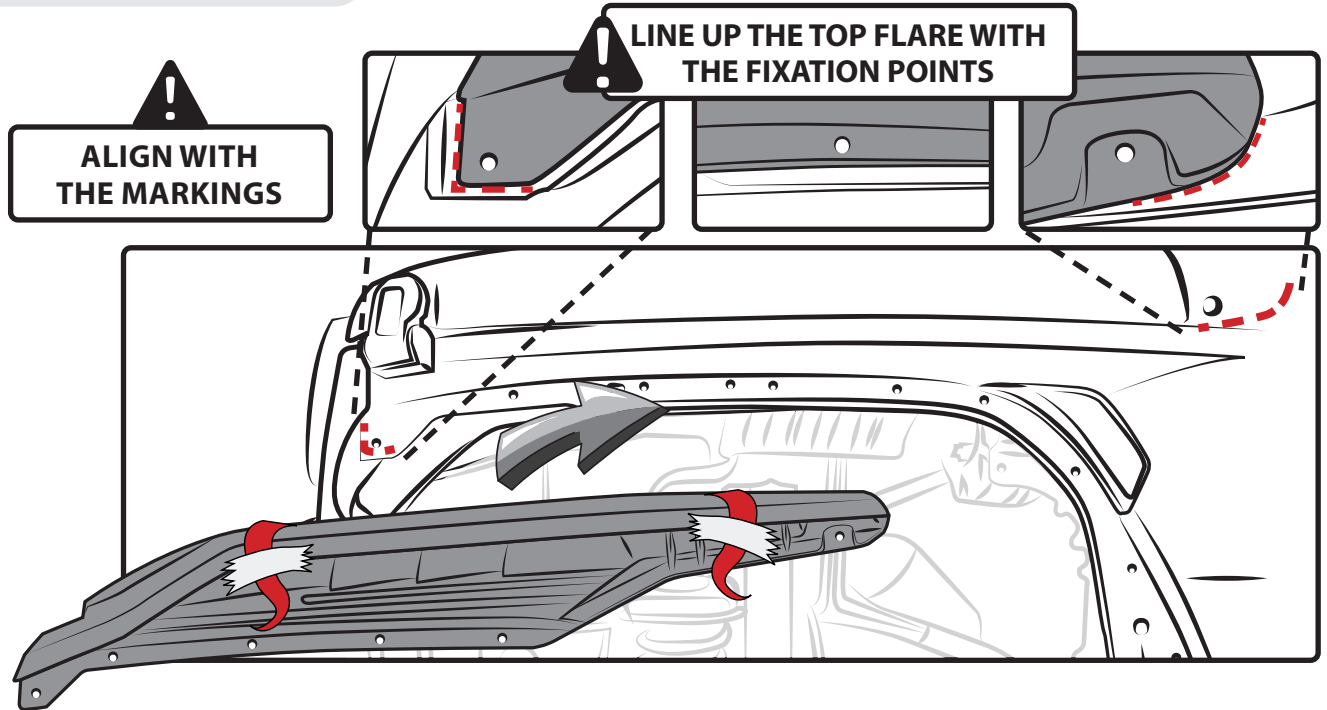

15 SCREW

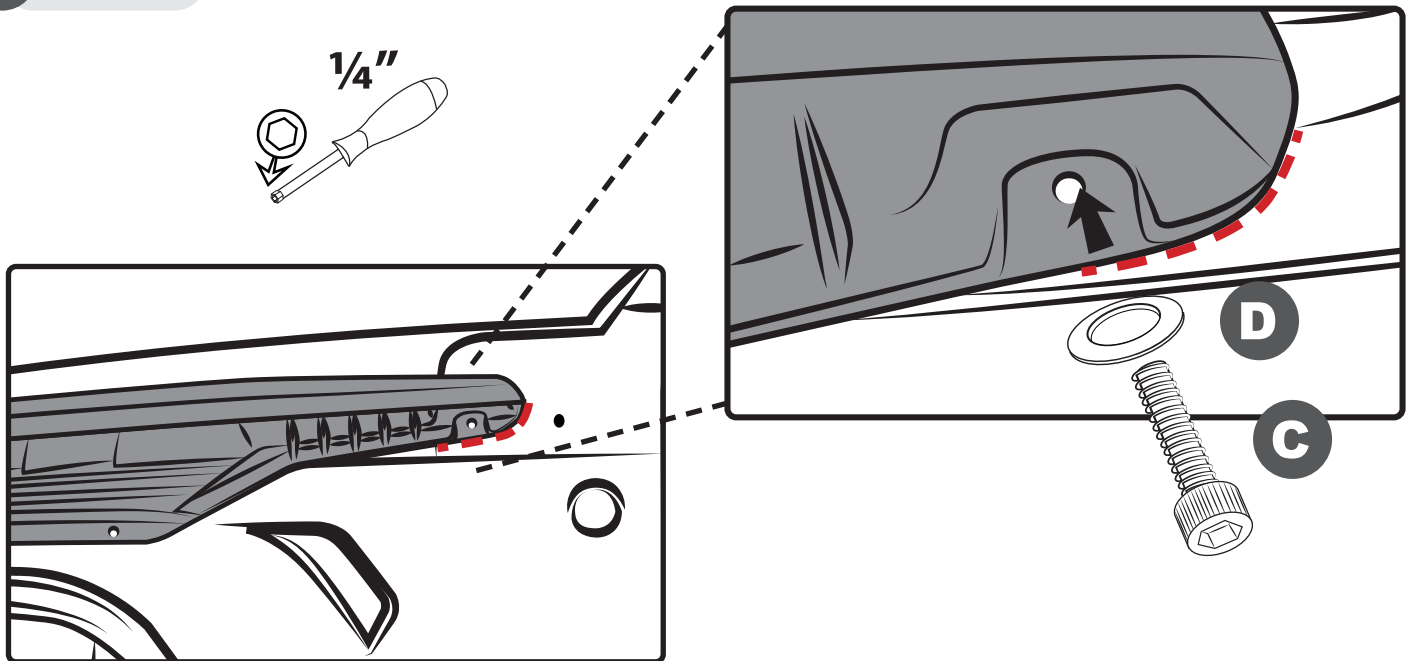

16 REMOVE THE LINER

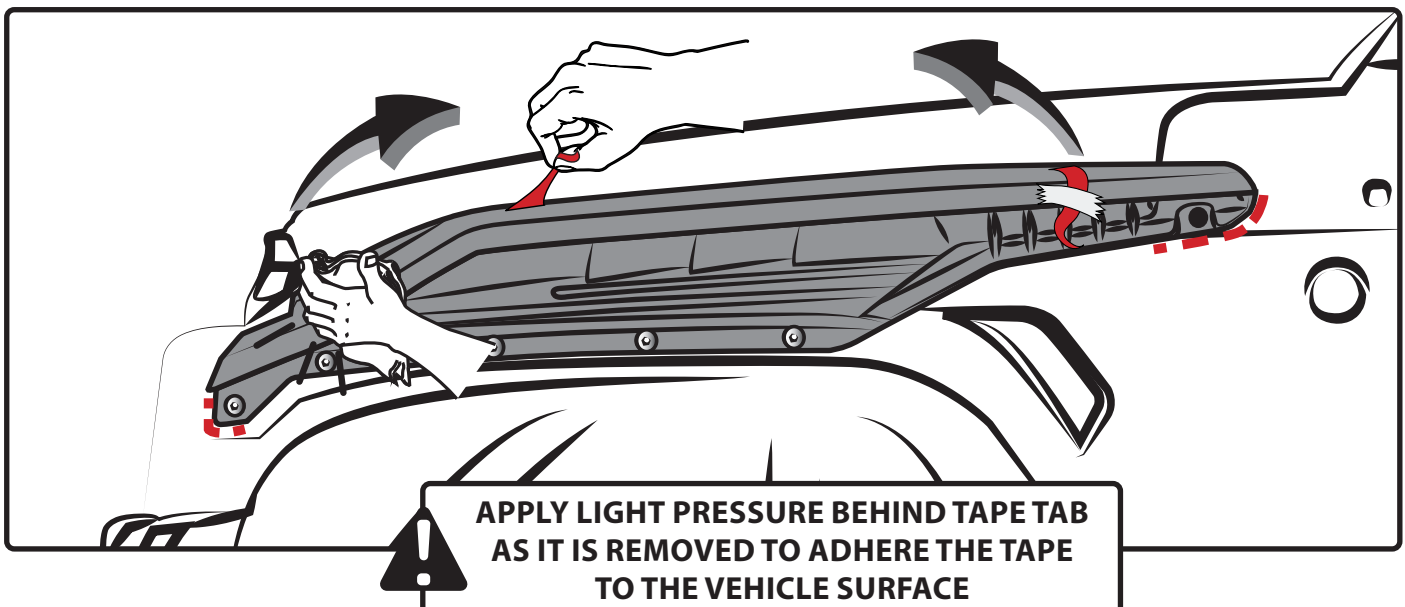

17 PRESS

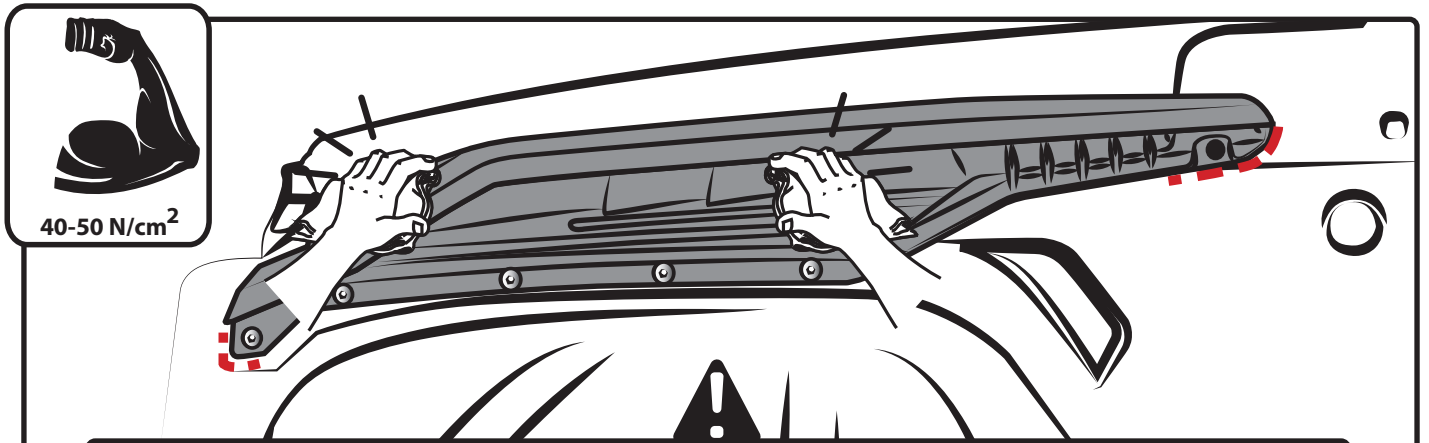

DURING APPLICATION, THE VEHICLE, ADD ON PARTS AND TAPE MUST BE AT OR ABOVE 16 °C OR 60 °F. A FULL SURFACE CONTACT BETWEEN TAPE AND SUBSTRATE IS IMPORTANT FOR GOOD ADHESION PERFORMANCE. CONTACT IS ACHIEVED BY APPLYING PRESSURE. IN PRACTICE, A PRESSURE BETWEEN 40 AND 50 N/CM² IS USUALLY NEEDED.

18 CLEAN THE MARKINGS

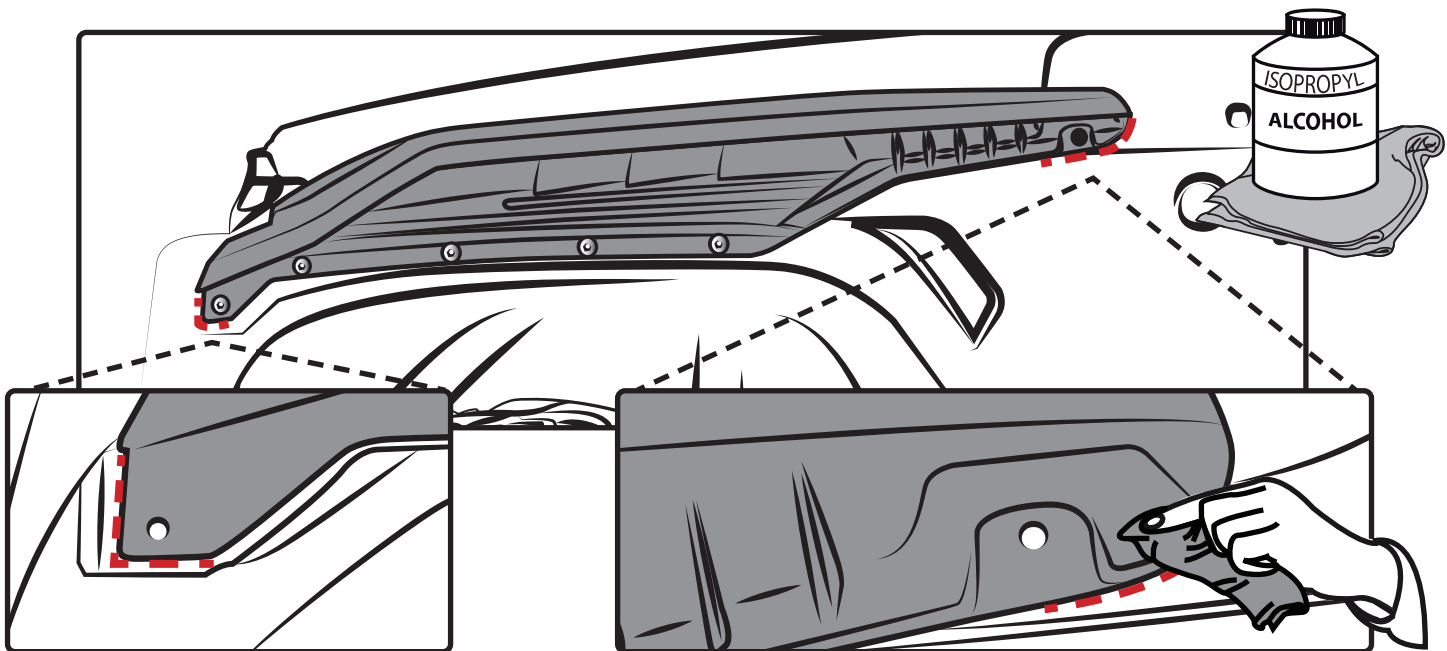

19 SECURE WITH AIR DESIGN SUPER BOLTS

! APPLY A SMALL AMOUNT OF THREAD LOCKER TO EACH BOLT AND SCREW

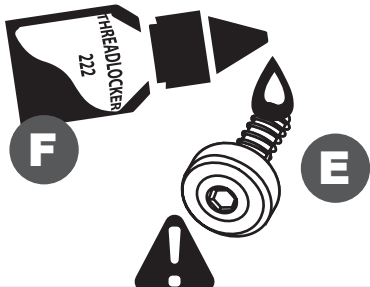

IF YOU ARE INSTALLING THE INNER FENDER LINER SET, DO NOT APPLY THREADLOCKER AT THIS POINT, BUT TEMPORARILY SECURE WITH AIR DESIGN SUPER BOLTS

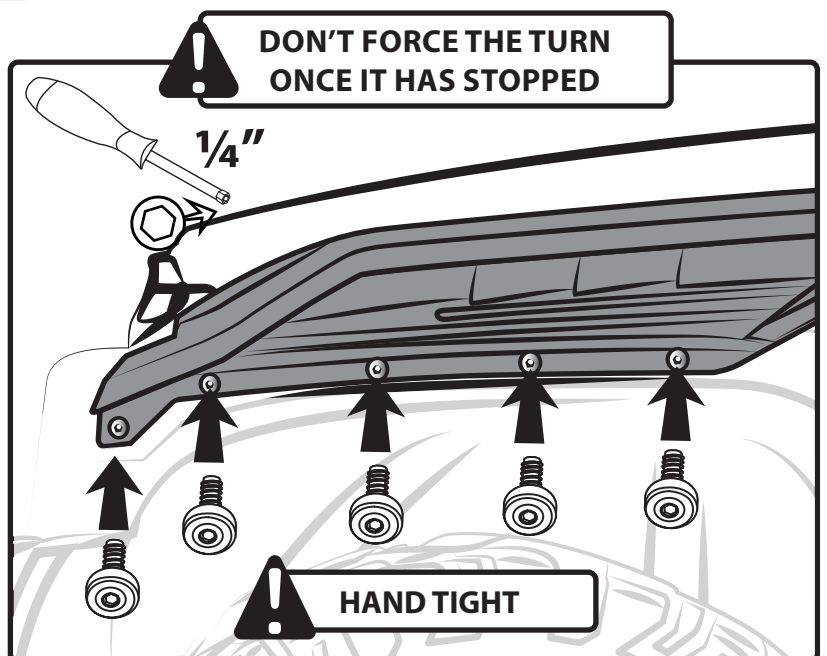

FLAT HIGH TOP FLARE SET - WRANGLER JL 2018+ INSTALLATION MANUAL

! The ideal temperature range of the part and the vehicle when installing must be 16°C (60°F) to 40°C (104°F), this guarantees a correct assembly.

REAR FLAT HIGH TOP FLARE

1 PLACE THE JACK NUTS

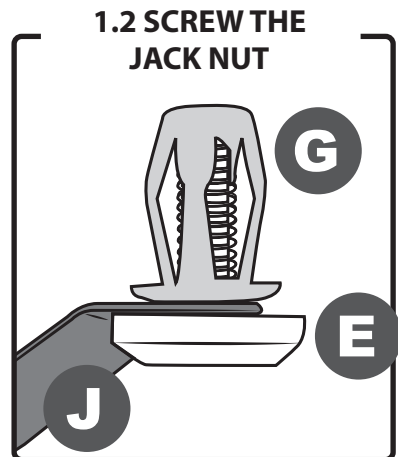
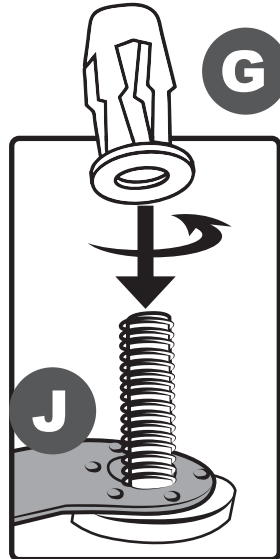
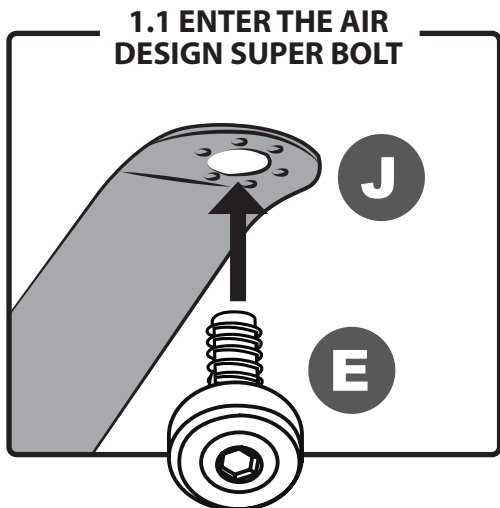
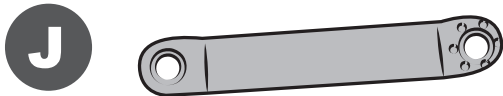
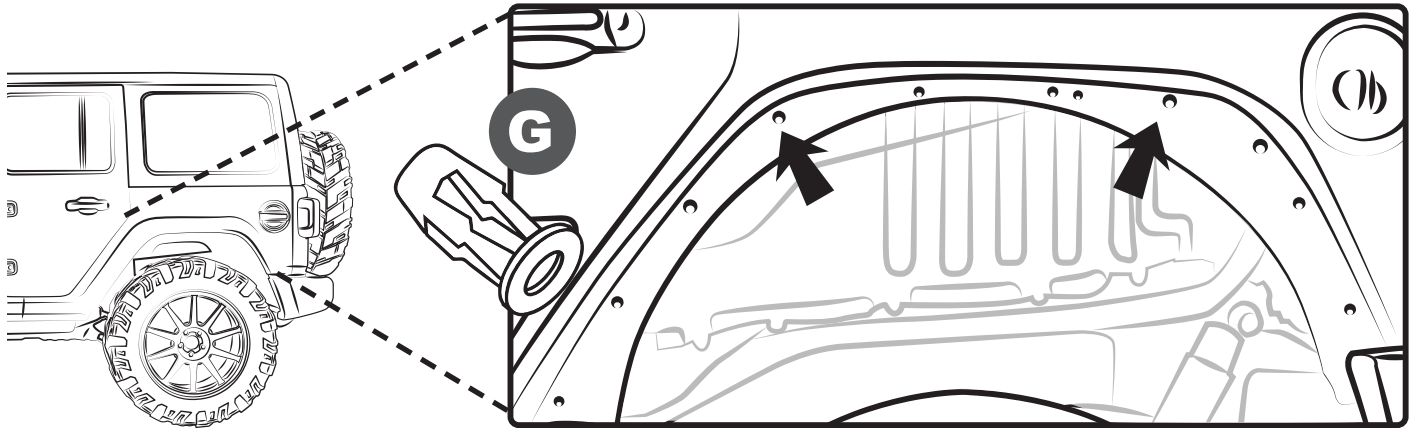

!
KEEP THE WRENCH
TILTED AND SCREW

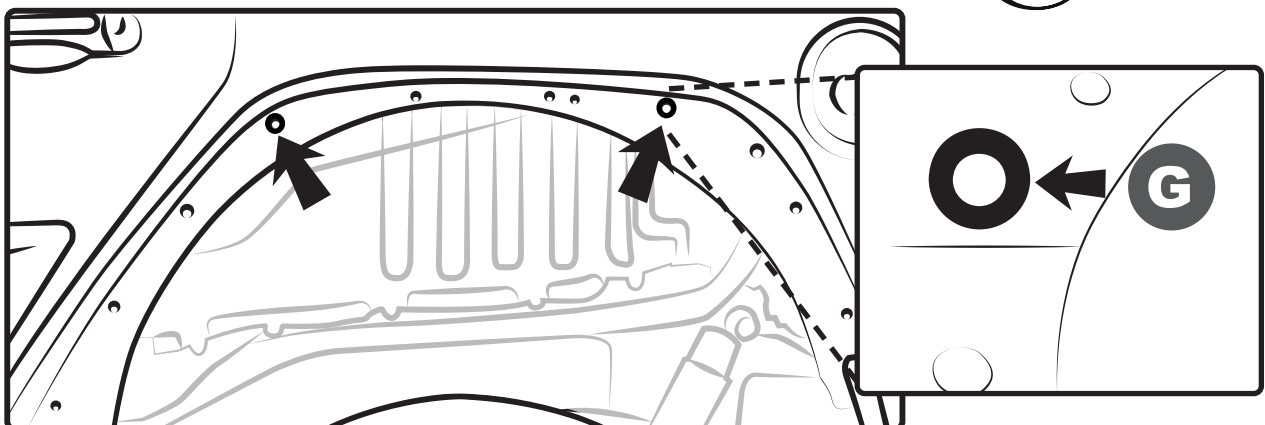
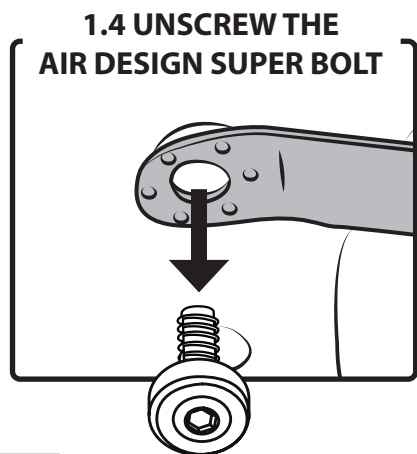
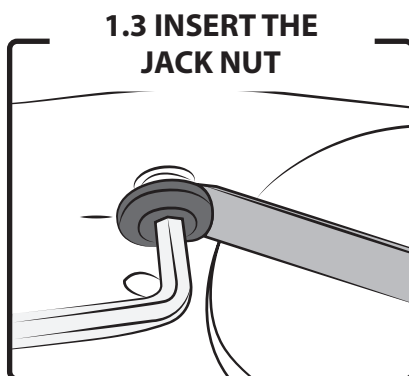
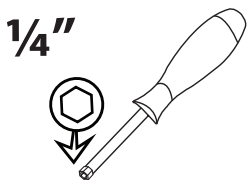

2 CLEAN THE FENDER INNER ZONE

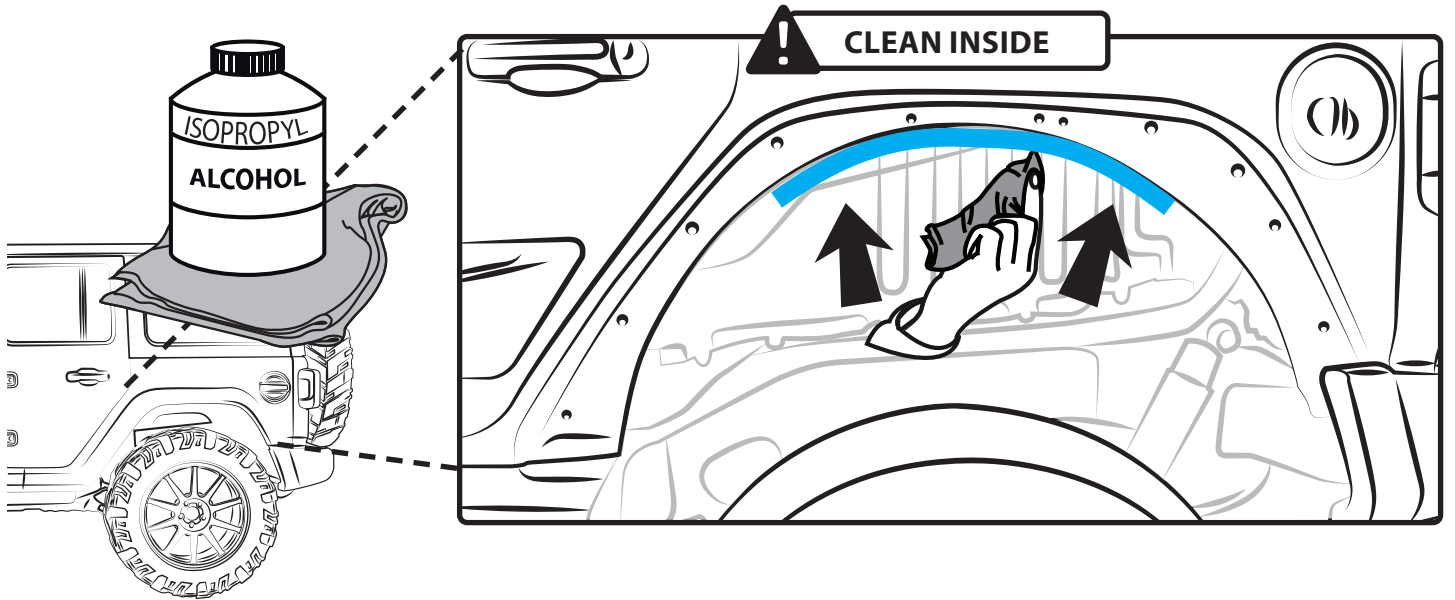

3 APPLY ADHESION PROMOTER ON THE FENDER INNER ZONE

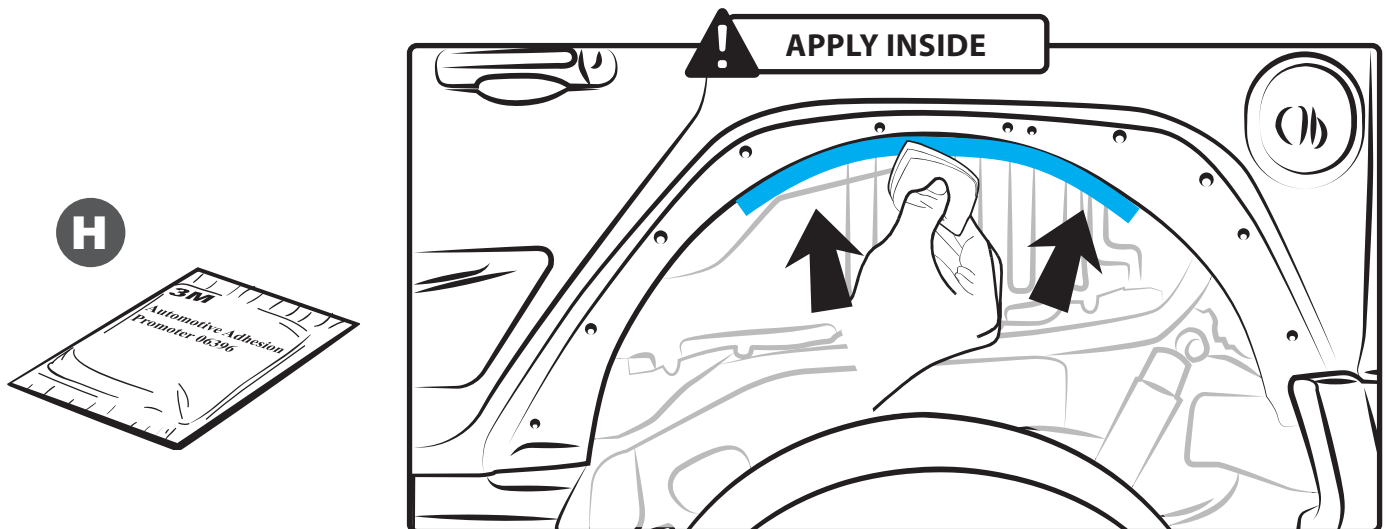

4 PEEL THE BRACKET

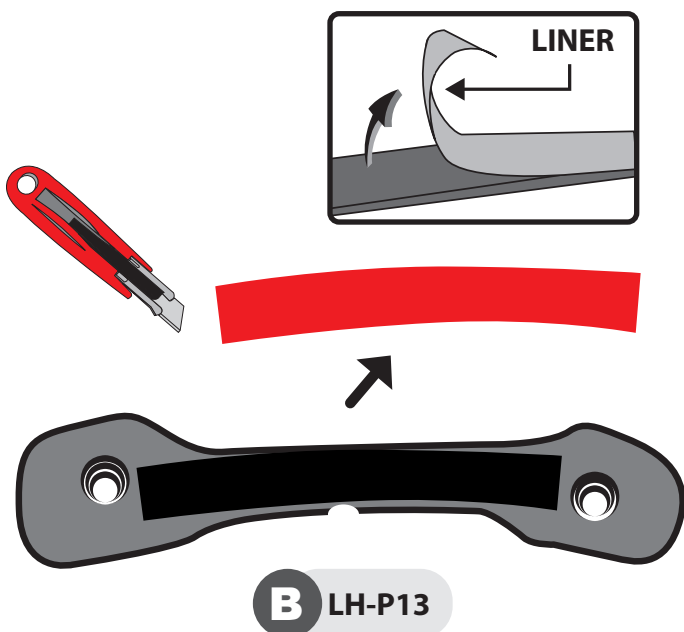

5 PLACE THE BRACKET

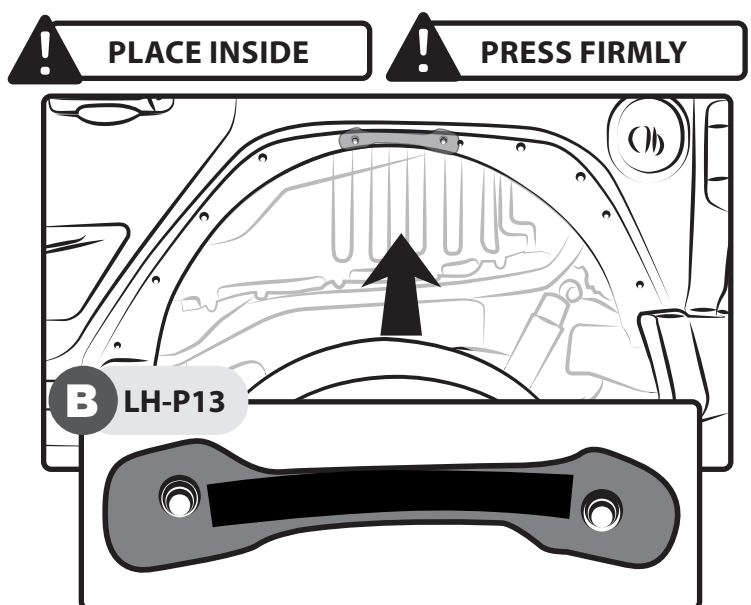

FLAT HIGH TOP FLARE SET - WRANGLER JL 2018+ INSTALLATION MANUAL

6 CLEAN THE INSTALLATION ZONE

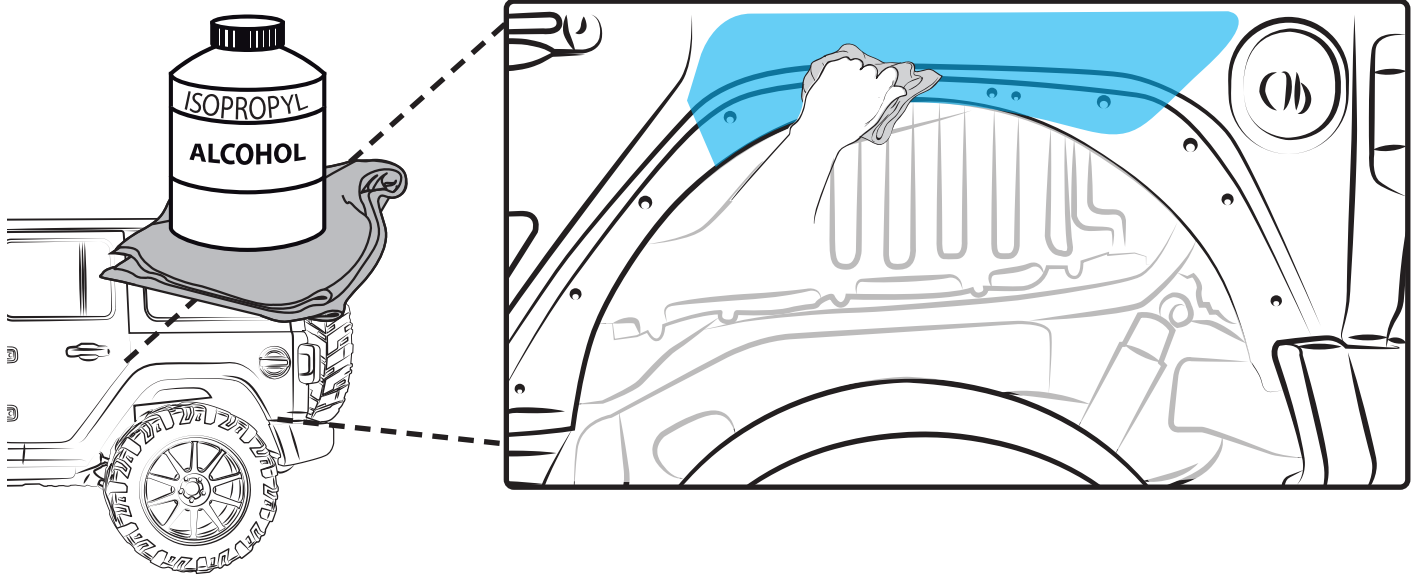

7 TEST FIT THE TOP FLARE

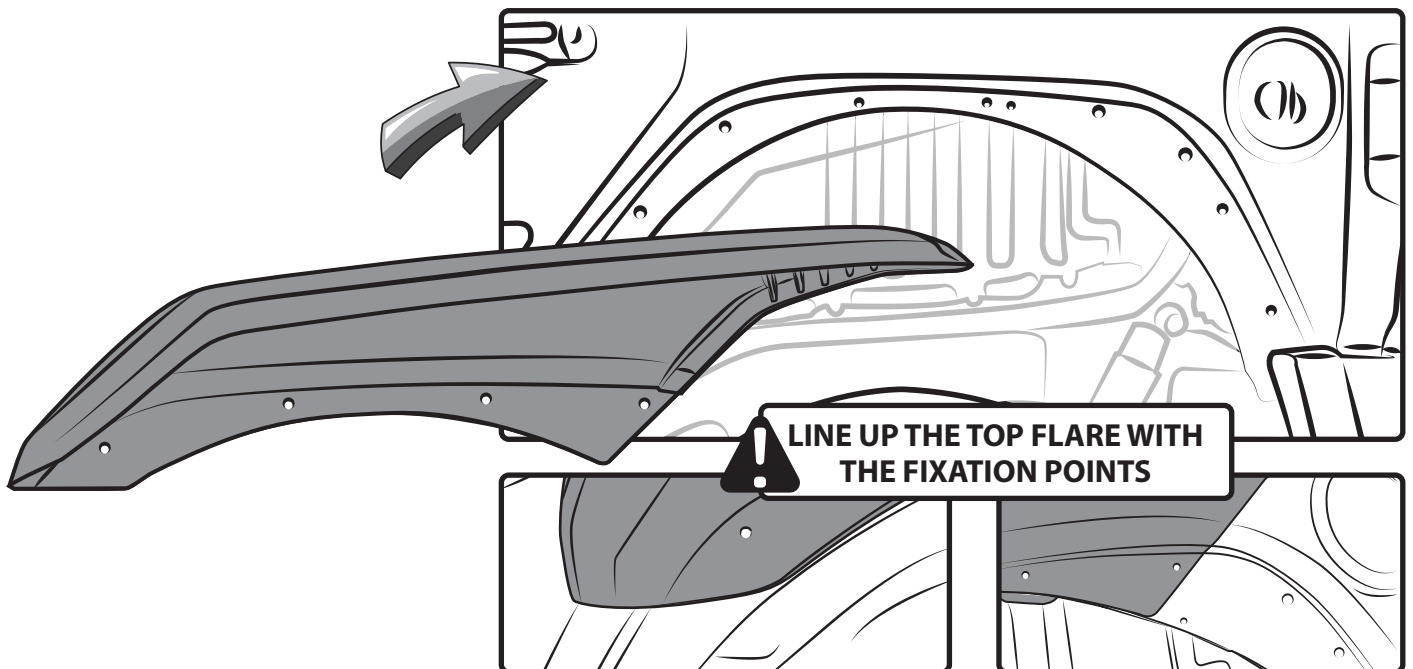

8 MARK AS SHOWN

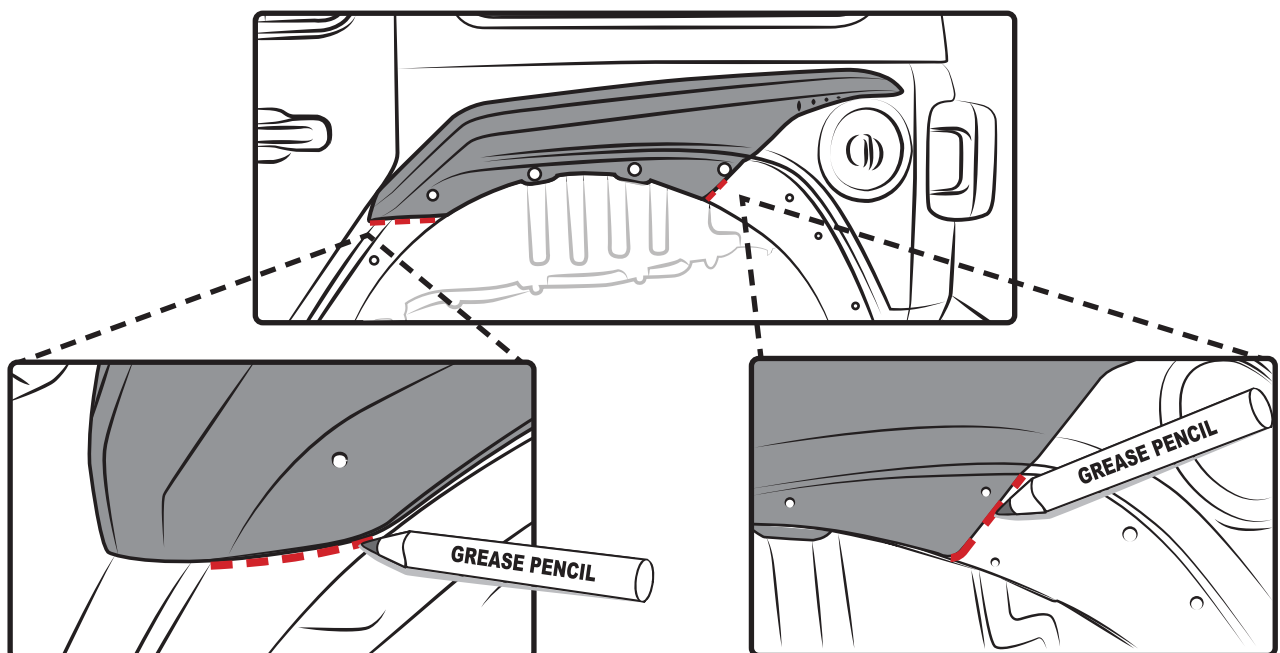

9 REMOVE THE TOP FLARE

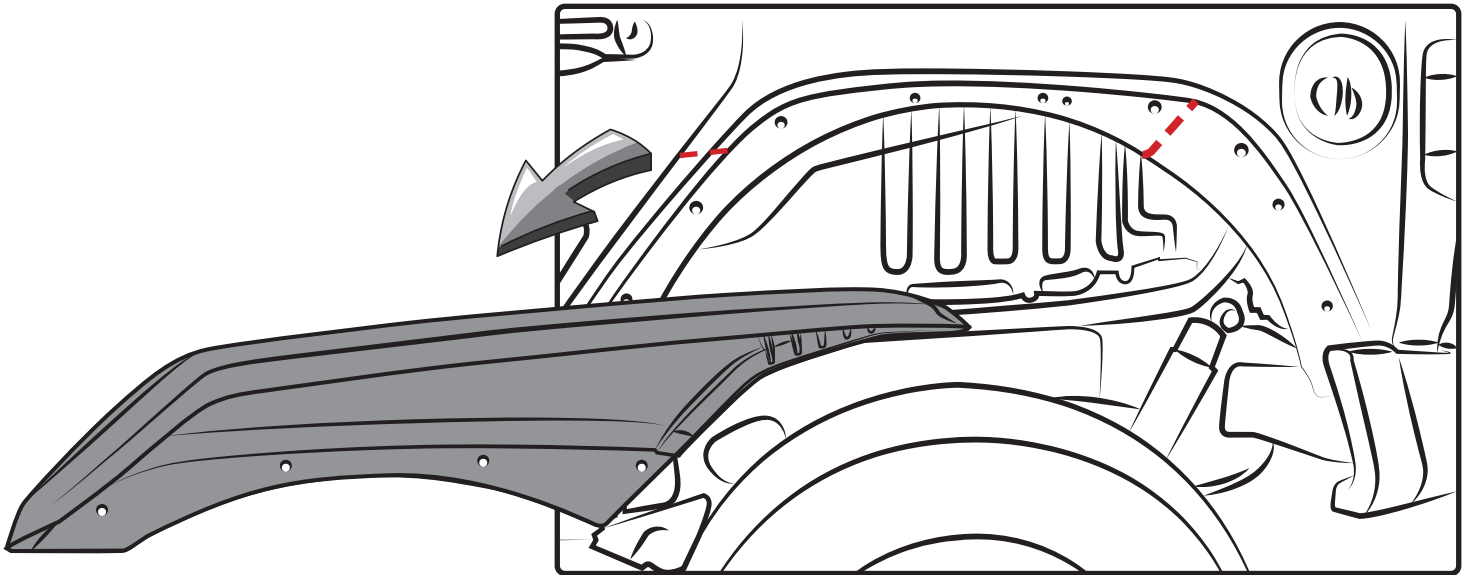

10 CLEAN THE ADHESIVE CHANNEL

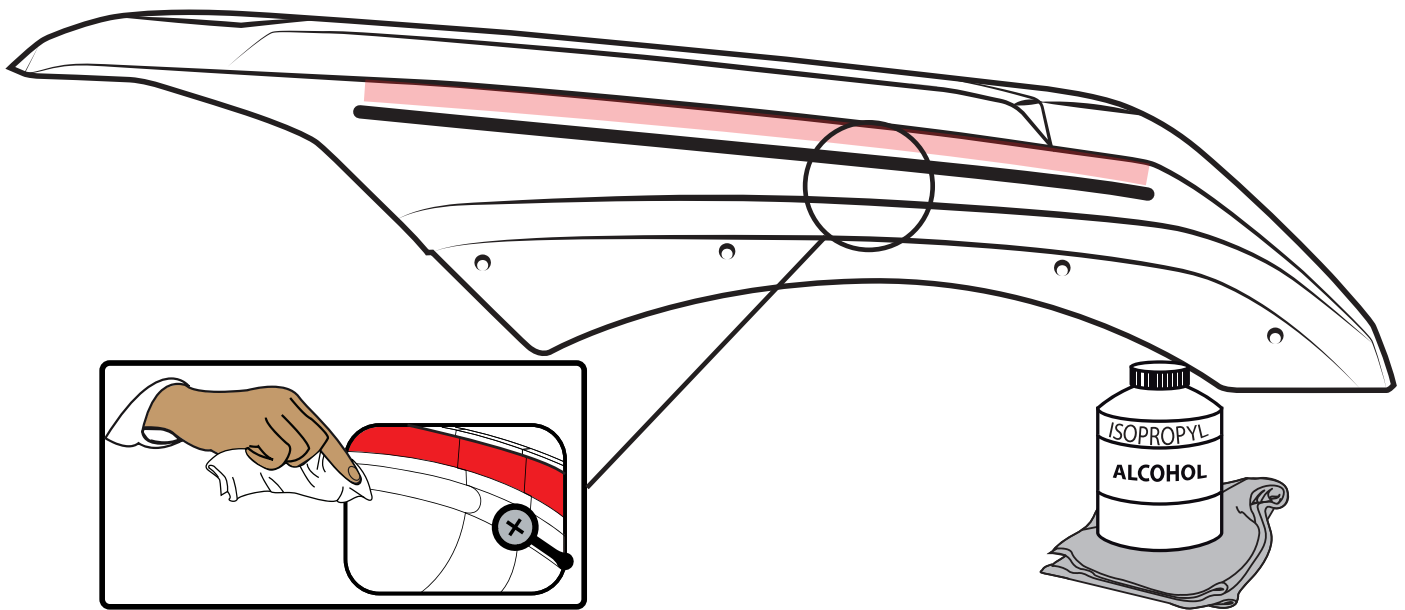

11 APPLY POLYURETHANE ADHESIVE

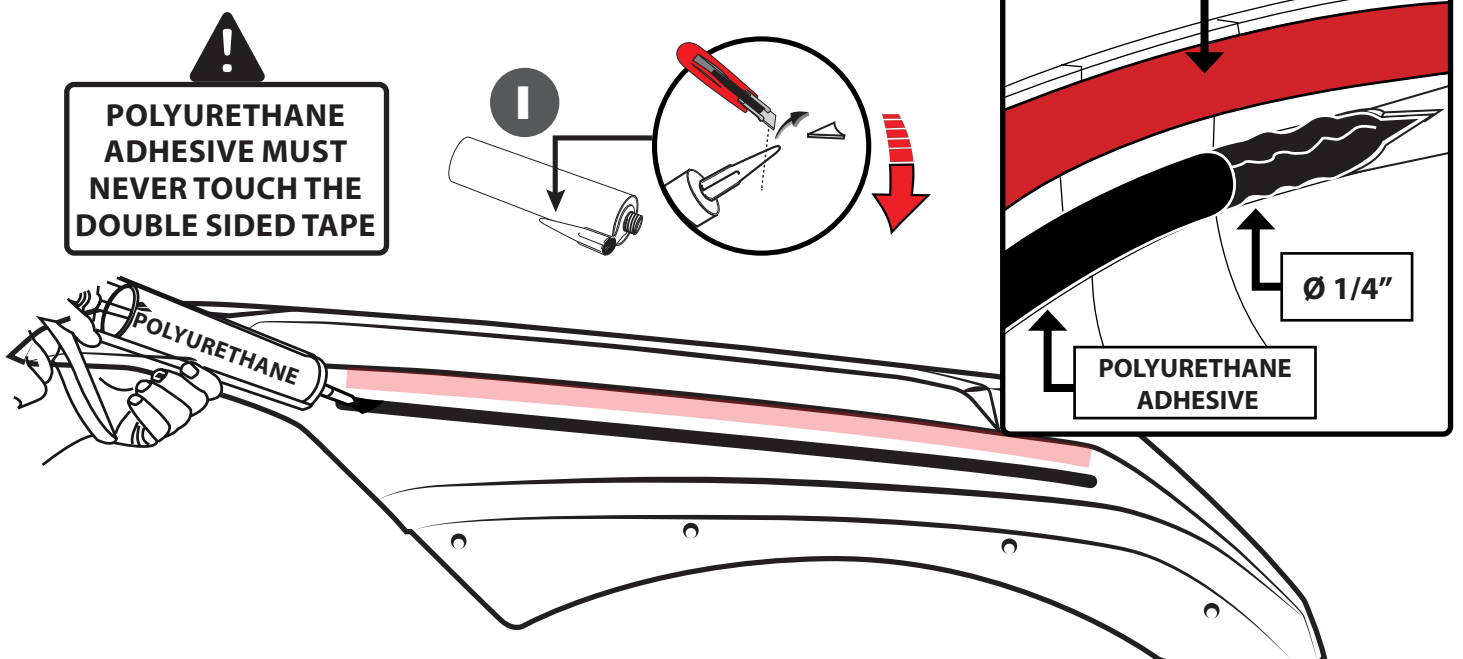

FLAT HIGH TOP FLARE SET - WRANGLER JL 2018+ INSTALLATION MANUAL

12 PEEL THE LINER LEADS

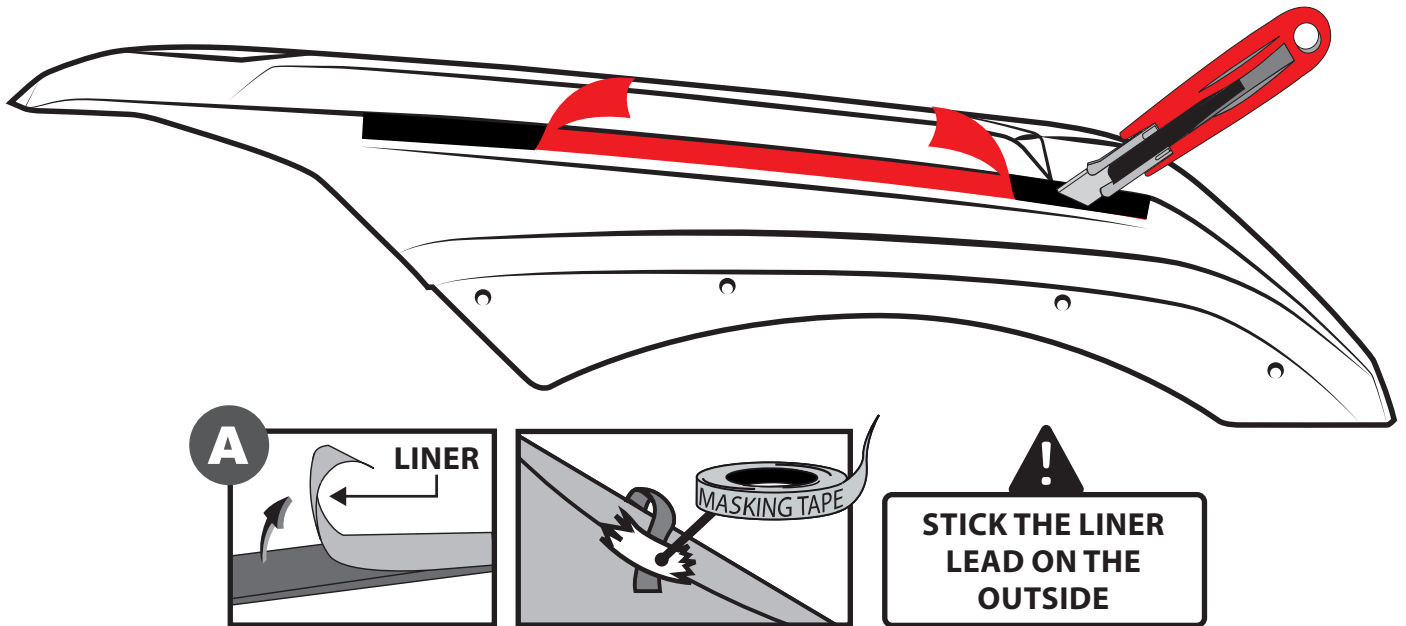

13 PLACE THE TOP FLARE

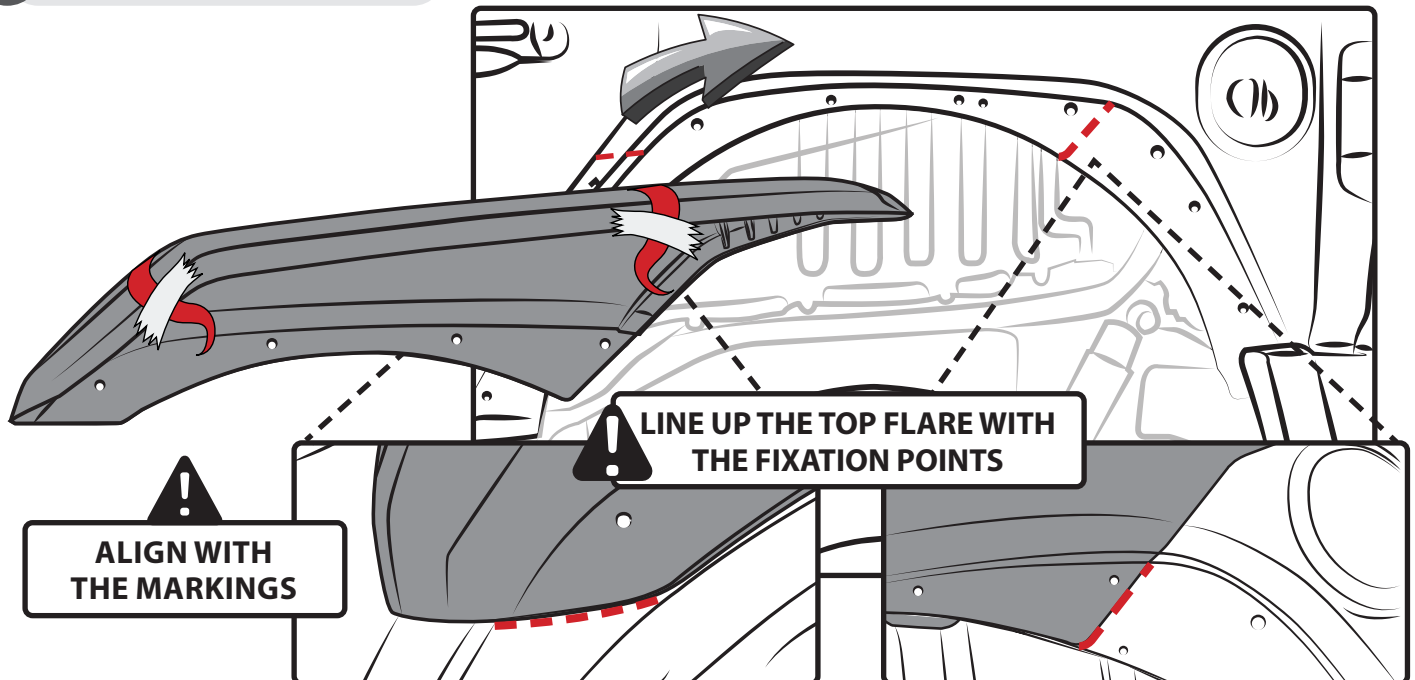

14 REMOVE THE LINER

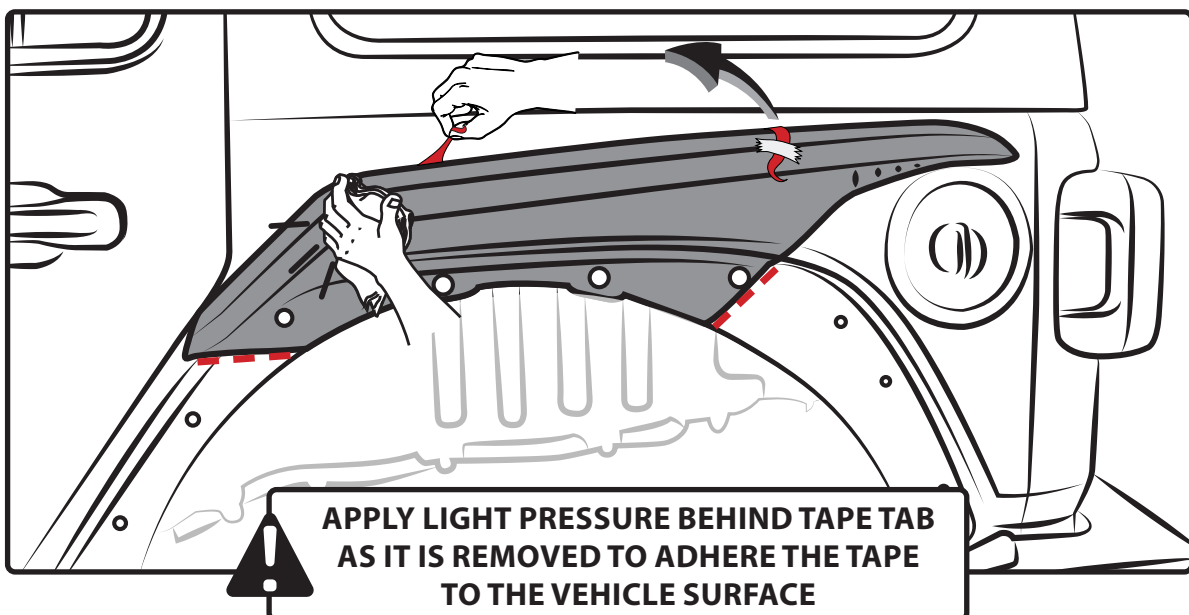

15 PRESS

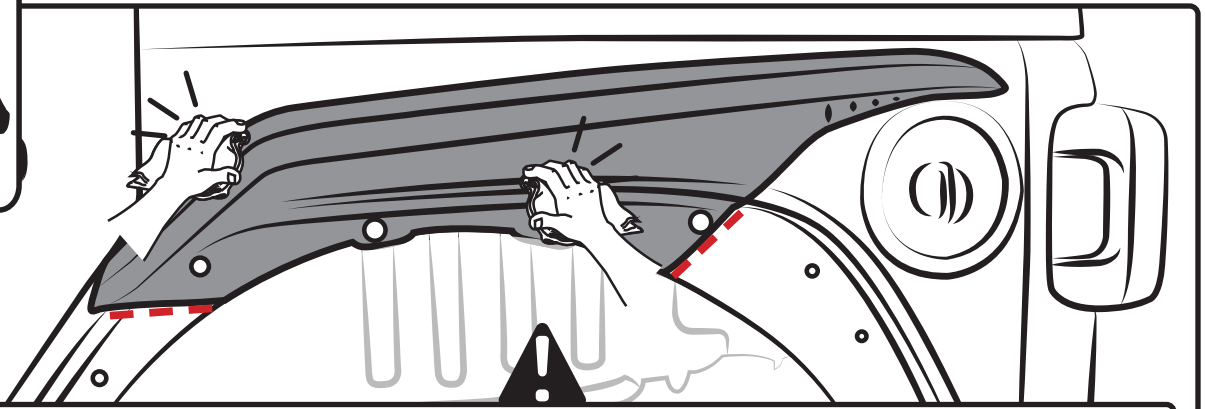

DURING APPLICATION, THE VEHICLE, ADD ON PARTS AND TAPE MUST BE AT OR ABOVE 16 °C OR 60 °F. A FULL SURFACE CONTACT BETWEEN TAPE AND SUBSTRATE IS IMPORTANT FOR GOOD ADHESION PERFORMANCE. CONTACT IS ACHIEVED BY APPLYING PRESSURE. IN PRACTICE, A PRESSURE BETWEEN 40 AND 50 N/CM² IS USUALLY NEEDED.

16 CLEAN THE MARKINGS

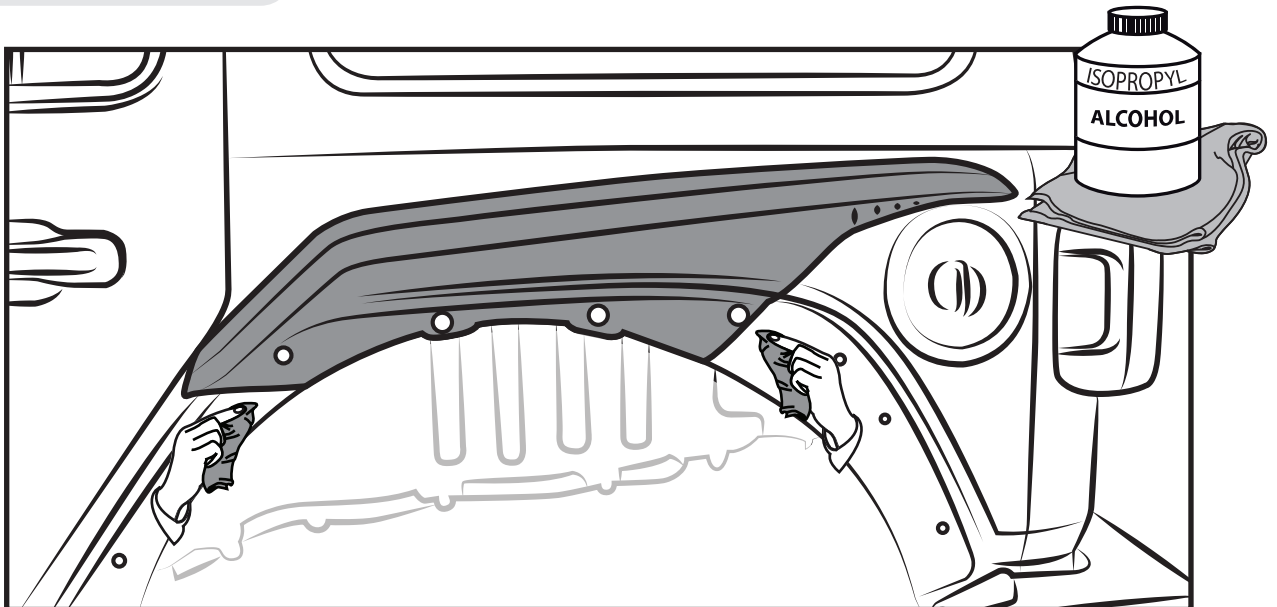

17 SECURE WITH AIR DESIGN SUPER BOLTS

! APPLY A SMALL AMOUNT OF THREAD LOCKER TO EACH BOLT AND SCREW

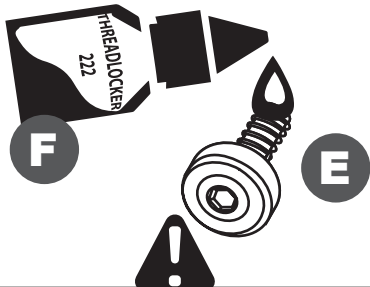

IF YOU ARE INSTALLING THE INNER FENDER LINER SET, DO NOT APPLY THREADLOCKER AT THIS POINT, BUT TEMPORARILY SECURE WITH AIR DESIGN SUPER BOLTS

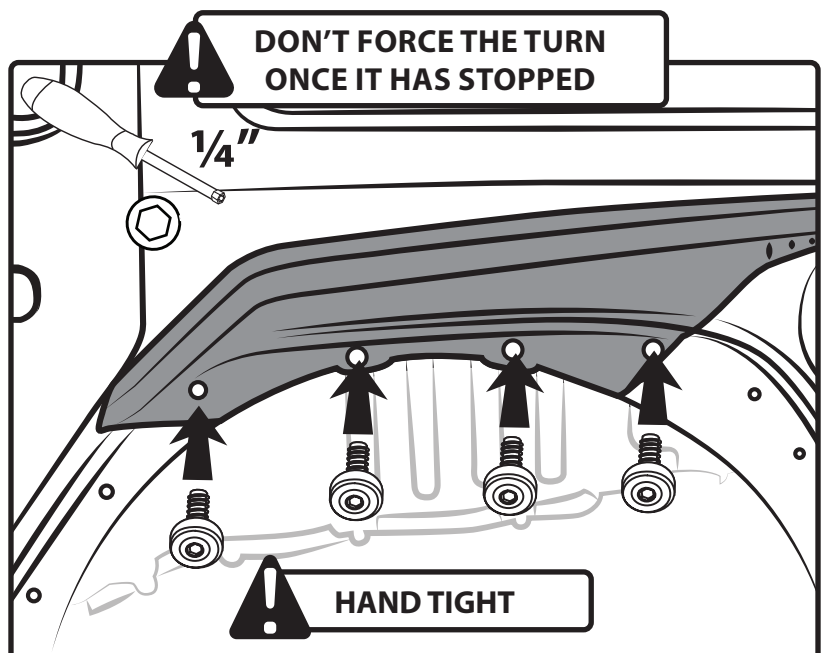

! HAND TIGHT

INSTALLED PART

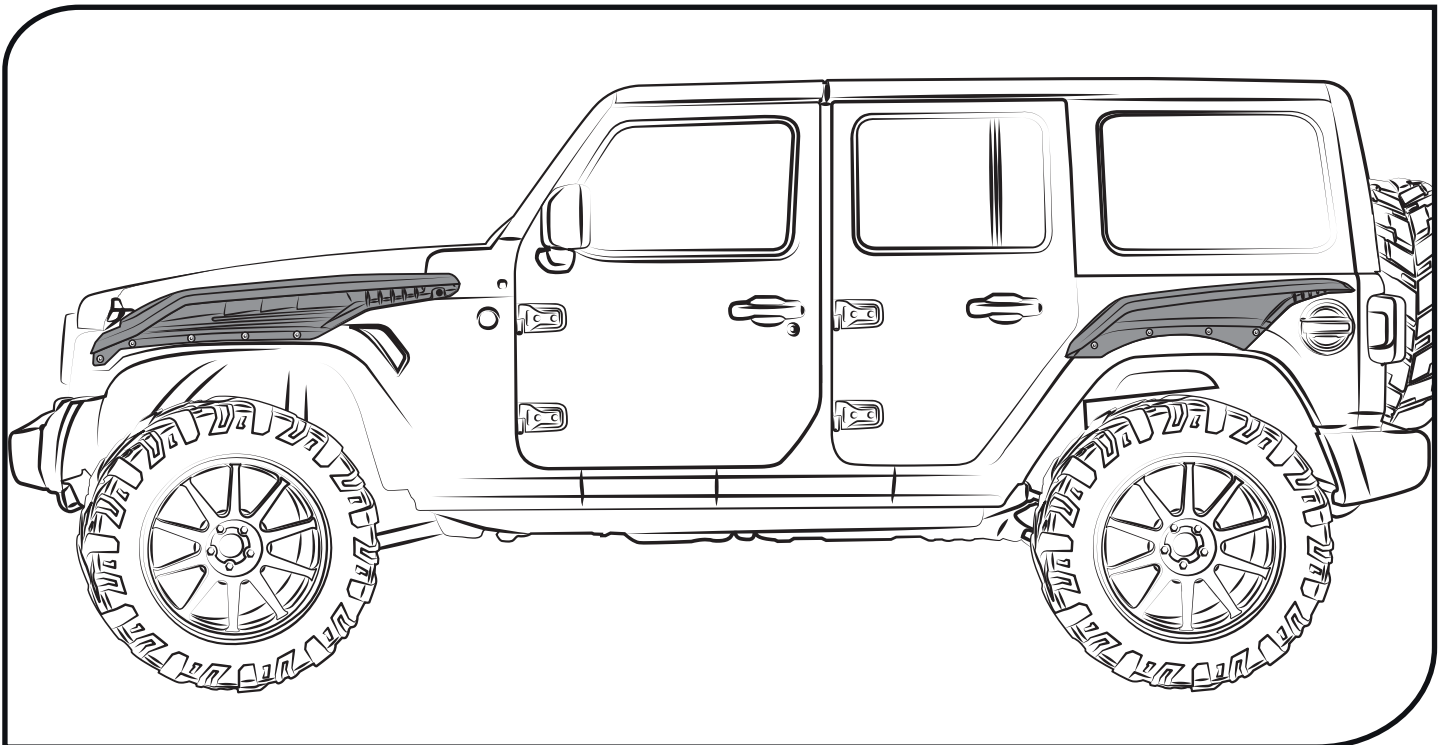

**REPEAT ALL STEPS
FOR RH SIDE**

JEEP-WRANGLER JL 2018+

GRIVE HIVE STYLE



AD - PART NUMBER: JE05A01

DOOR PANEL SET

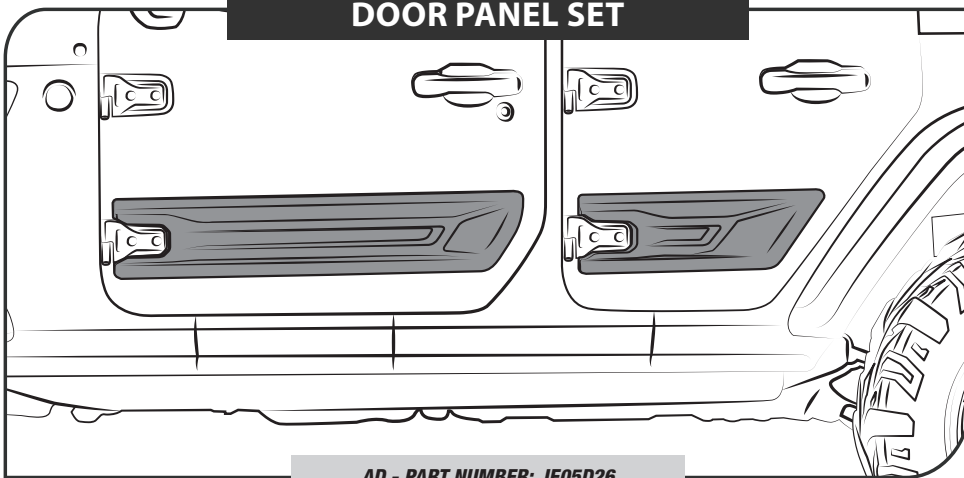

AD - PART NUMBER: JE05D26

IMPORTANT:

IF YOU INSTALL BOTH SETS, ALWAYS START WITH INSTALLATION FROM THE FLAT TOP HIGH FLARE SET

1. FLAT TOP HIGH FLARE SET

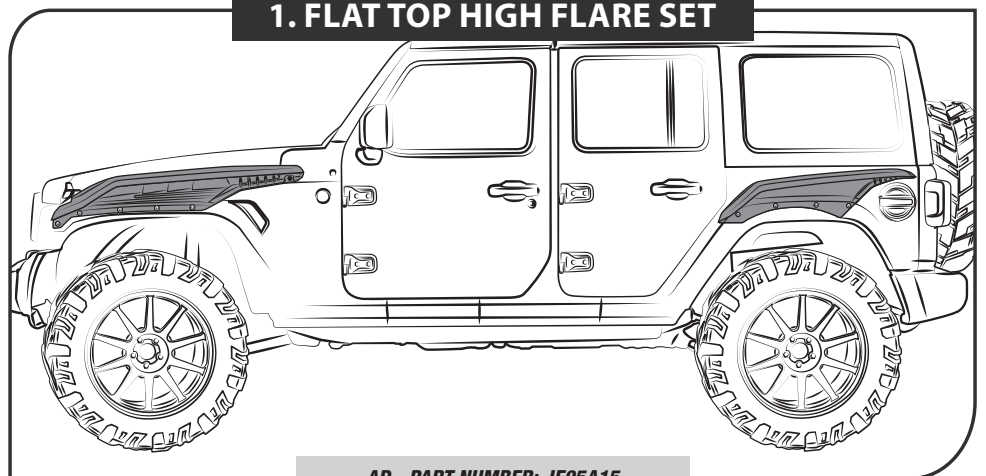

AD - PART NUMBER: JE05A15

2. INNER FENDER LINER SET

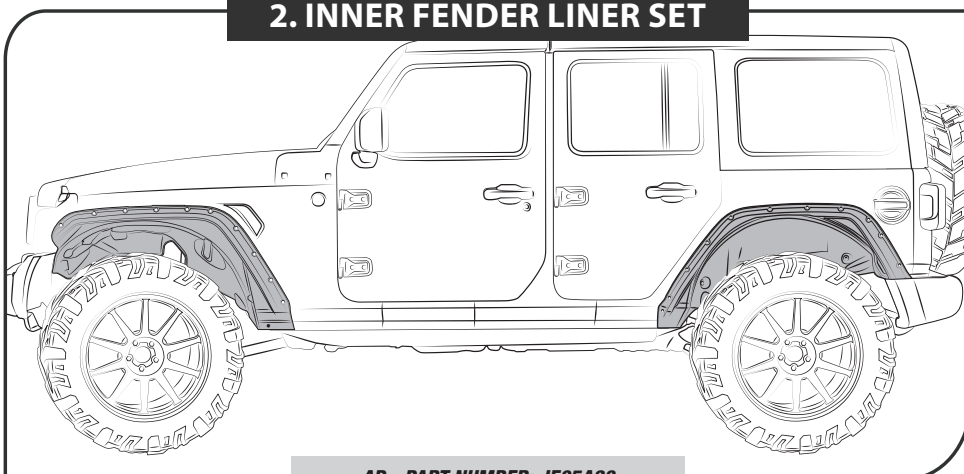

AD - PART NUMBER: JE05A20