



RS66128B Jeep Gladiator Crawler Short Arm System
 3 ½" Rubicon, 4 ½" NON-Rubicon Progressive Coils*
 Fits 2020 Jeep Gladiator JT Rubicon

*The addition of aftermarket bumpers, sliders, winches, etc. will net differences in lift height

Some boxes in this kit may contain separate Installation Instructions. Follow Installation Instructions for the kit you are installing (see parts list).

This suspension system was developed using 38x13.5xR17 tires. Before installing any other size tire, consult your local tire and wheel specialist. See page 4.



Pictured with:
 Milestar Patagonia M/T 38X13.50R17
 Vision Nemesis 17" x 9" -12 wheel (4.5" backspacing)

⚠ WARNING

Carefully read, understand and follow the instructions provided in this manual, and keep it in a safe place for future reference. If you have any doubt whatsoever regarding the installation or maintenance of your Rancho suspension system, please see your retailer for assistance or advice. Failure to follow the warnings and instructions provided herein can result in the failure of the suspension system, or can cause you to lose control of your vehicle, resulting in an accident, severe personal injury or death.

These instructions should remain in the vehicle glove box for future reference.

⚠ WARNING: READ ALL INSTRUCTIONS THOROUGHLY FROM START TO FINISH BEFORE BEGINNING INSTALLATION. Failure to follow the warnings and instructions provided herein can result in an accident, severe personal injury or death.

PRELIMINARY

This manual presumes that all persons installing this suspension system have a high level of mechanical training and experience, and have available to them all necessary tools and safety equipment. This manual is not and should not be construed as an exhaustive list of all required safety measures. Personnel should rely primarily on their training and experience, as well as on their own common sense.

This Manual is to be read as a supplement to, and must not be construed as a substitute for, the owner's manual and/or shop manual that originally accompanied the vehicle. Refer to such use, operation, maintenance and safety manuals as necessary, and especially after installation is complete, to insure proper vehicle operation.

The following terminology has been used in this Manual:

ACCIDENT: Any event which could cause personal injury or death to anyone installing or using the suspension system, as well as to passengers and bystanders, or otherwise may result in property damage.

PRE-INSTALLATION WARNINGS and INSTRUCTIONS

⚠ WARNING: Only the following wheel / tire size may be used with this suspension system: Milestar Patagonia M/T 38X13.50R17, 17" x 9" -12 wheel (4.5" backspacing).

Use of any other rim/tire combination increases the risk of a roll-over and/or accident, resulting in severe personal injury or death.

⚠ WARNING: This suspension system will enhance the off-road performance of your vehicle. It will handle differently; both on and off-road, from a factory equipped passenger car or truck. Failure to drive this vehicle safely may result in serious injury or death to the driver and passengers. ALWAYS WEAR your seat belts, REDUCE your speed, and AVOID sharp turns and other abrupt maneuvers.

1) Service and repair tasks require specialized knowledge, training, tools, and experience. General mechanical aptitude may not be sufficient to properly install this suspension system. If you have any doubt whatsoever regarding your ability to properly install the suspension system, please consult a qualified mechanic.

2) Your brake lines and fuel lines should remain undisturbed during and after installation. If you think you need to modify these components in any way, you are mistaken. You are installing the lift improperly and will be creating a significant risk of an accident. In case of any doubt, consult a qualified mechanic.

3) If any component does not fit properly, something is wrong. You are installing the lift kit improperly and will be creating a significant risk of an accident. Never modify any component of the vehicle or suspension system, except as instructed herein. Do not continue with installation until you have identified the problem.

4) Several of the procedures described herein require at least two (2) persons to safely complete the task. If you have any doubt about your ability to complete any operation by yourself, always ask for help from a qualified assistant.

5) Before starting any operation, confirm that all personal safety devices and safety equipment are in proper condition and position.

6) Give your work undivided attention. Looking around, carrying on a conversation and "horse-play" are careless acts that can result in an error in installation and/or serious injury.

7) Install only tires approved by the United States Department of Transportation ("DOT approved"). Make sure the rim and tire size are properly matched.

8) If any components of the vehicle or suspension system are damaged in any way during installation, immediately replace the component.

9) During installation, carefully inspect all parts of the vehicle and replace anything that is worn or damaged.

10) Nip points present the risk of the catching, lacerating, crushing and/or amputating fingers, hands, limbs and other body parts during operations. Always keep clear. Wear protective gloves.

11) Oil and hydraulic fluids are poisonous, dangerous to health and are known to the State of California to cause cancer, birth defects or other reproductive harm. Do not inhale vapors or swallow. Do not allow contact with the eyes or skin. Should any oil or fluids be swallowed or inhaled or come into contact with the eyes, immediately follow the safety precautions on the label or call a poison control center immediately. Should any of the oil or fluids contact your skin, immediately wash thoroughly.

12) Never install the suspension system if you are under the effects of alcohol, medications and/or drugs. If you are taking prescription or over the counter medication, you must consult a medical professional regarding any side effects of the medication that could hinder your ability to work safely.

AFTER INSTALLATION WARNINGS AND INSTRUCTIONS

13) After installation is complete, drive the vehicle slowly in an area free from heavy traffic for at least three (3) miles. Likewise, before traveling on any highways or at a high rate of speed, drive the vehicle for ten (10) miles on side roads at moderate speed. If you hear any strange noise or feel unusual vibration, if a component of the suspension system is not operating properly, or if any warning lights illuminate or buzzers sound, stop the vehicle immediately. Identify the cause and take any necessary remedial action.

14) Confirm that all components of the vehicle, including all lights (headlights, turn signals, brake lights, etc.), linkages (accelerator, etc.), electrical switches and controls (windshield wipers and defoggers, etc.), and other warning devices (low tire pressure monitoring systems) are fully operational.

15) Your headlights will need to be readjusted before the vehicle is used on the roads. Consult the vehicle owners' manual.

16) The speedometer and odometer will need to be recalibrated after installation. See your dealer.

17) Confirm proper rear view and side view while seated in the driver seat. Install supplemental mirrors as necessary.

18) Your original low tire pressure monitoring system may be re-installed in your new wheels. However, if you choose to purchase a new system, see your dealer to have them properly calibrated. Proper tire pressure is critical to safe operation of the vehicle.

OPERATION

19) Because it has been modified, the vehicle will not handle, turn, accelerate or stop in the same manner as an unmodified vehicle. In addition, the crash protection systems designed in the vehicle may operate differently from an unmodified vehicle. For example, turning and evasive maneuvers must be executed at a slower rate of speed. Further, there is a greater risk that the vehicle could roll over. These differences could result in an increased possibility of an accident, personal injury or death. Learn the vehicle's operations and handling characterizes and drive accordantly.

IMPORTANT NOTES

- A. Before installing this system, have the vehicle's alignment and frame checked by a certified technician. The alignment must be within factory specifications and the frame of the vehicle must be sound (no cracks, damage or corrosion). Have all suspension, steering and driveline components inspected and replaced if worn or damaged
- B. The components of Rancho's suspension system are designed as a single integrated system. To avoid compromises in terms of safety, performance, durability or function, do not install a body lift kit with Rancho's suspension system or interchange parts from this system with components from another manufacturer. Use of other components will result in the forfeiture of any type of warranty on the vehicle/suspension system.
- C. Some components required for the installation of this kit may need to be purchased separately. See "SPECIFICATIONS & REQUIREMENTS" on next page of this manual.
- D. Compare the contents of this system with the parts list in these instructions. If any parts are missing, contact the Rancho Technical Department at 1-800-325-8886.
- E. Do not powder-coat or plate any of the components in this system. To change the appearance of components, automotive paint can be applied over the original coating.
- F. Each hardware kit in this system contains fasteners of high strength and specific size. Do not mix hardware kits or substitute a fastener of lesser strength. See bolt identification table at end of instruction.
- G. Install all nuts and bolts with a flat washer. When both SAE (small OD) and USS (large OD) washers are used in a fastener assembly, place the USS washer against the slotted hole and the SAE washer against the round hole.
- H. Apply a drop of thread locking compound to all bolts during installation. ⚠ CAUTION: Thread locking compound may irritate sensitive skin. Read warning label on container before use.
- I. Unless otherwise specified, tighten all nuts and bolts to the standard torque specifications shown in the table at end of instruction. USE A TORQUE WRENCH for accurate measurements.
- J. Do not weld anything to these components, and do not weld any of these components to the vehicle unless specifically stated in the instructions. Welding on a vehicle creates an electrical charge throughout the body and frame. Disconnect the vehicle's battery prior to any welding. Place welding ground clamps as near as possible to the weld. Never use a vehicle suspension component as a welding ground point.
- K. It is extremely important to replace coil springs, axle flanges, and drive shaft/pinion relationships as original. Be sure to mark left/right, front/rear, and indexing of mating parts before disassembly. A paint marker or light colored nail polish is handy for this.
- L. Suspension components that use rubber or urethane bushings should be tightened with the vehicle at normal ride height unless otherwise specified. This will prevent premature failure of the bushing and maintain ride comfort.
- M. Some of the service procedures require the use of special tools designed for specific procedures. If you do not know how to safely use any of these tools, or do not have them, stop the project and consult a qualified mechanic. See "Tools and Supplies" on next page of this manual
- N. The required installation time for this system is approximately 4 to 5 hours for two people. Check off the box (☐) at the beginning of each step when you finish it. Then when you stop during the installation, it will be easier to find where you need to continue from.
- O. Important information for the end user is contained in the consumer/installer information pack. If you are installing this system for someone else, place the information pack on the driver's seat. Please include the installation instructions when you finish.
- P. The lifespan of Rancho products depends on many factors. Improper use, abuse or harsh use in general may compromise the integrity of the suspension system and significantly reduce its lifespan. The suspension system is also subject to wear over time. Have the suspension system regularly inspected and maintained by qualified mechanics. If the inspection reveals any damage or excessive wear, no matter how slight, immediately replace or repair the component. The suspension system must be regularly maintained in order to optimize its safe and efficient use. The more severe the conditions under which the suspension system is operated, the more often it must be inspected and maintained.
- Q. If any component breaks or bends, contact your local Rancho dealer or Rancho for replacement parts or, contact the Rancho Technical Department at 1-800-325-8886.

Thank you for purchasing the best suspension system available. For the best installed system, follow these instructions. If you do not have the tools or are unsure of your abilities, have this system installed by a certified technician. RANCHO IS NOT RESPONSIBLE FOR DAMAGE OR FAILURE RESULTING FROM AN IMPROPER INSTALLATION

The driver of this suspension system recognizes and agrees that there are risks inherent in driving a vehicle with a lifted suspension system, including but not limited to the risk that you could be involved in an accident that would not occur in an unmodified vehicle. By his/her purchase and use of this suspension system, the user expressly, voluntarily and knowingly accepts and assumes these risks, and agrees to hold DRiV, Inc. and its related companies harmless to the fullest extent permitted by law against any resulting damages.

SPECIFICATIONS & REQUIREMENTS

Average lift heights on OE vehicle with no additional accessories or load:

Rubicon: 3 ½" Front, 2 ½" Rear

NON-Rubicon: 4 ½" Front, 3 ½" Rear

Optional HD Rear Coil Available (MUST BE PURCHASED SEPARATELY)

For constant loads over 500lbs,

RS80139 X-Lander Rear Lift Progressive Coil Spring kit is available separately, and provides 3 ½" Rear lift (unloaded).

Required Components and Modifications (MUST BE PURCHASED SEPARATELY)

Shock Absorbers:

New Rancho shock absorbers must be used with this kit, and must be purchased separately

Do not reuse OE shock absorbers

⚠️WARNING Use of the wrong shock absorbers can cause damage to vehicle without the damage being visible to you, resulting in loss of vehicle control and an accident

Required Rancho Shock Absorbers

Front	Rear
RS55065	RS55070
RS999065	RS999070
RS55067*	
RS999067*	

*Requires replacement front driveshaft (see below)

Wheels and Tires

This suspension system was developed using the following tire & wheel combination:

Tire: Milestar Patagonia M/T 38X13.50R17

Wheel: Vision Nemesis 17" x 9" -12 wheel (4.5" backsparing)

Total backsparing 6"

Maximum total backsparing is 6.8".

Before installing any other combination, consult your local tire and wheel specialist.

Compatible With OE Wheels	Development Tire Size ^{2,3} (Actual)	Alternate Tire Size ³ (Actual)	Wheel Size (Backspacing)
Yes ¹	38x13.50R17	37x12.50R17	17x9
OE Tires ONLY	(37.5"x13.5")	(36.5"x12.5")	(4.5")

¹ OE wheels compatible with stock size tires only.

² May requires slight trimming fenders and fender well liner.

³ Requires removal of front bumper plastic side trim. See page 9.

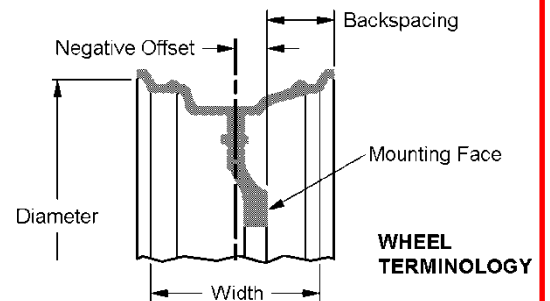

WHEEL TERMINOLOGY

Tools and Supplies (BECAUSE OF VEHICLE VARIATIONS, THIS MAY NOT BE A COMPLETE LIST)

Jeep Service Manual	3/8" and 1/2" Drive Ratchet and Socket Sets	File
Hydraulic Floor Jack	Combination Wrenches	Red Loctite
Heavy Duty Jack stands	Wire Brush (to clean mounting surfaces)	Penetrating Lube (to aid removal of corroded and frozen hardware)
Wheel Chocks (Wooden Blocks)	Body Clip Removal Tool	Safety Glasses--
Torque Wrench (250 FT-LB capacity)	Hammer	Wear safety glasses at all times
Heavy Duty Spring Compressor	Pliers	

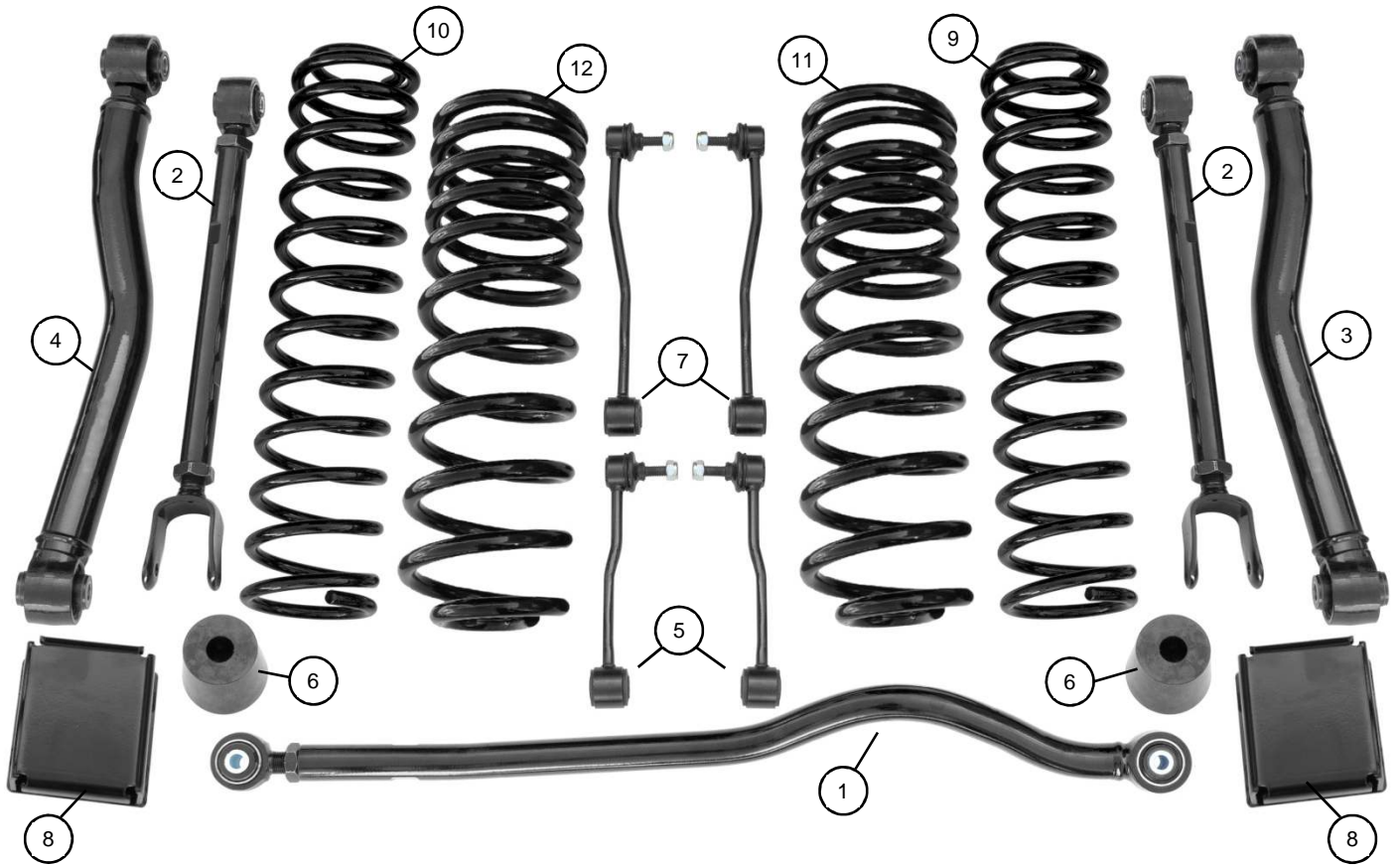

Parts List

ITEM	P/N	DESCRIPTION	QTY
	RS66128B-1	Box 1, Front Components	1
1	RS881030B	Front Track Bar	1
2	RS881031B	Front Upper Control Arm	2
3	RS881032BL	Front Left Lower Control Arm	1
4	RS881032BR	Front Right Lower Control Arm	1
5	RS176901	Front Sway Bar End Link	2
6	RS176802	Front Bump Stop 3"	2
	RS860851	Sub Assy, Front Bump Stop	1
	RS603602	HHCS, 3/8-16 X 1.75	2
	RS7604	Nut, 3/8-16 Nylock	2
	RS603508	Washer, 3/8 SAE	4
	RS860874	Sub Assy, Front Sway Bar End Link	1
	RS7719	Washer, 1/2" USS	1
	RS89125	Instructions – RS66125B	1
	RS94180	Information Pack	1
	RS94177	Rollover Warning Label	1
	RS94119	Consumer/Warranty Information	1
	R-RM0082-1112	Warranty Tag	1
	RS780281	Rancho Decal - Color	1
	RS780294	Red Rancho Die Cut Decal	1
	RS780294B	Black Rancho Die Cut Decal	1

ITEM	P/N	DESCRIPTION	QTY
	RS66128B-2	Box 2, Rear Components	1
7	RS176902	Rear Sway Bar End Link	2
8	RS176960	Rear Bump Stop spacer, 2.50"	2
	RS860830	Sub Assy - Bump Stop Hardware	1
	RS770127	HHCS M8-1.25X20MM	4
	RS770128	Washer M8 (Hardened)	8
	RS603112	Nut 8mm-1.25 Nylock	4
	RS86128	Instructions – RS66128	1
	RS66128B-3	Box 3, Front Coil Springs	1
9	RS869B	Left Front Coil Spring	1
10	RS870B	Right Front Coil Spring	1
	RS66128B-4	Box 3, Rear Coil Springs	1
11	RS881B	Left Rear Coil Spring	1
12	RS882B	Right Rear Coil Spring	1
	RS88138	Instructions – RS80138	2

FRONT SUSPENSION

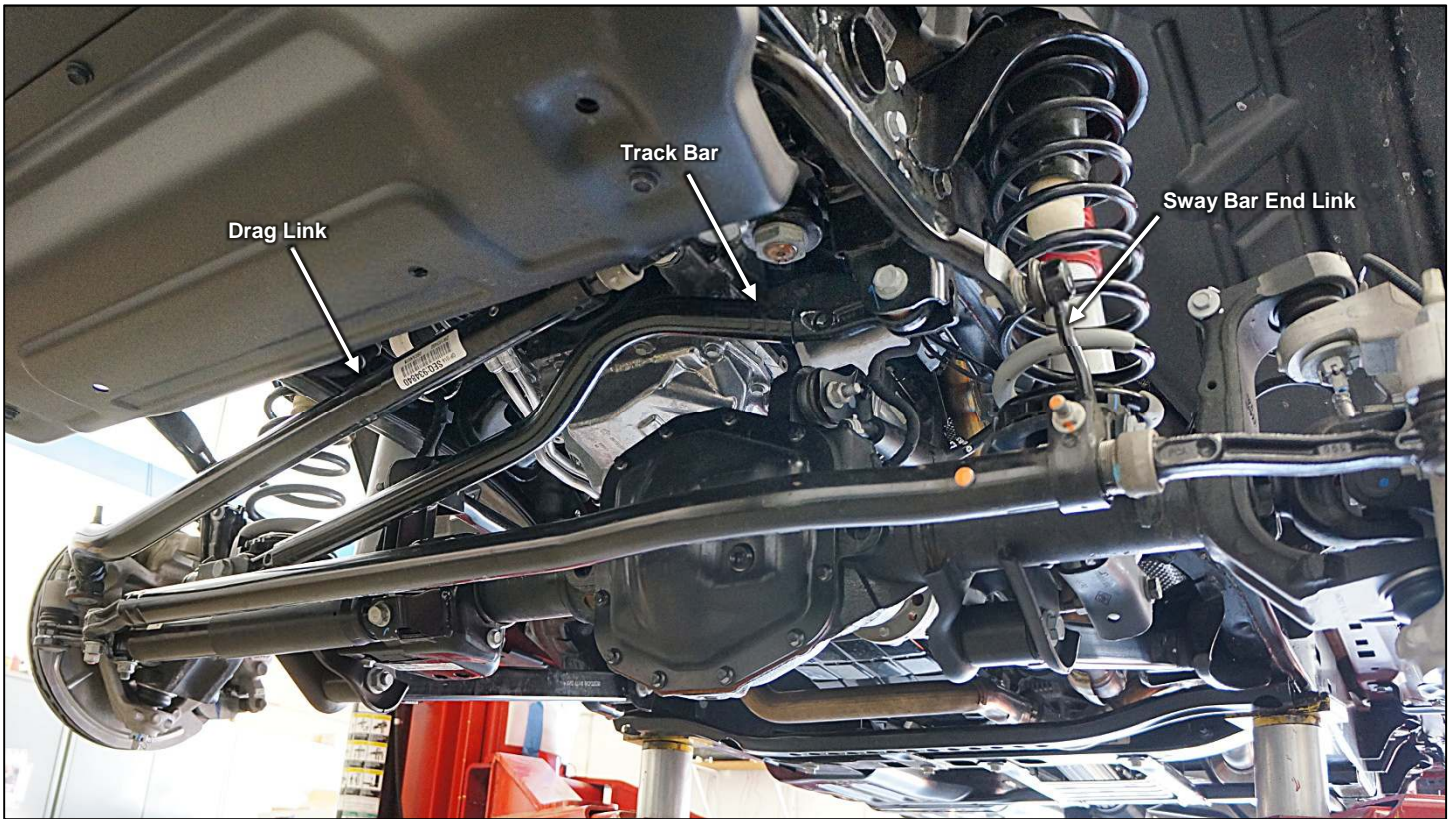

Illustration 1

SHOCK ABSORBER & COIL SPRING REMOVAL

- 1) Park vehicle on a level surface. Set the parking brake and chock rear wheels. Disconnect the negative ground cable from the battery.
- 2) Measure and record the distance from the center of each wheel to the top of the fender opening. See Illustration 2.

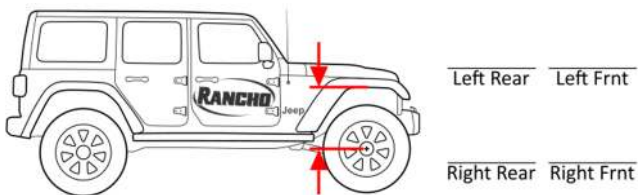

Illustration 2

- 3) Remove the track bar to frame bracket nut and bolt. See Illustration 1.
- 4) Raise the front of the vehicle and support the frame with jack stands. Remove the front wheels and set them aside.
- 5) Remove the sway bar end links. To avoid mixing the different thread pitches used, thread nuts back onto ball stud and mounting bolt and save for later use.
- 6) Remove nut and separate the brake hose bracket from the lower control arm. See Illustration 3.

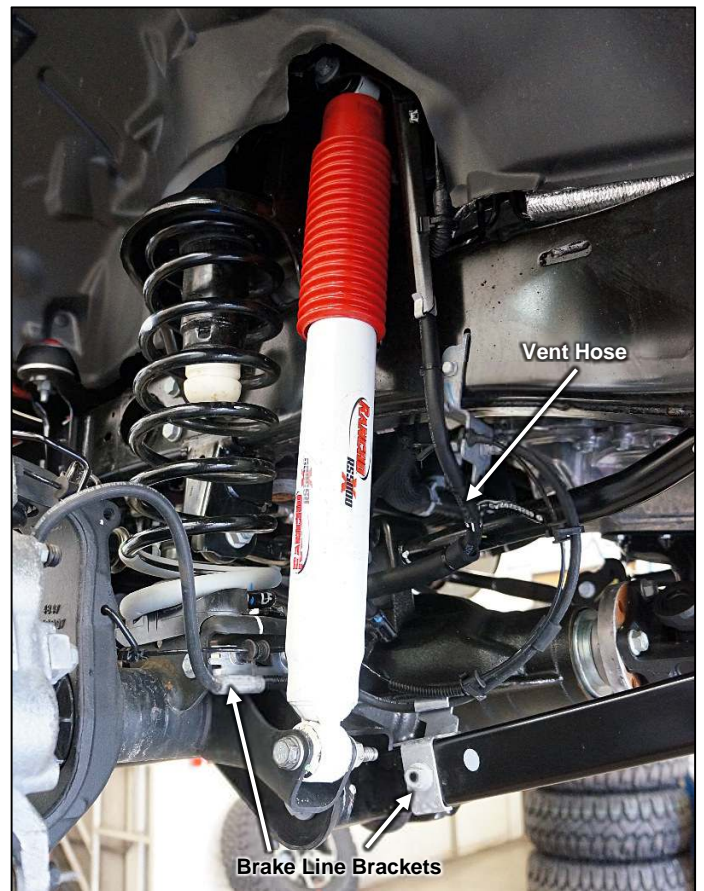

Illustration 3

7) Remove bolt and separate the brake hose bracket from the axle. See Illustration 3.

8) Disconnect any vent hoses.

9) Disconnect any electrical wiring from the axle by sliding out the plug lock and pulling plug out. Detach wire clips from axle and upper control arms. See Illustration 4.

CAUTION: DO NOT PULL BY WIRES!

10) Reference mark the drive shaft to the front pinion flange (at axle). Disconnect the drive shaft from the pinion flange. Support drive shaft with a tie wrap or wire. See Illustration 5.

Take care not to damage driveshaft CV boot at transfer case.

11) Remove heat shields on upper control arm frame mount. See Illustration 5.

12) Loosen, but DO NOT REMOVE upper and lower control arm bolts

13) Support the front axle with a floor jack.

14) Remove the shock absorber lower nut and bolt.

15) Remove the shock absorber upper bolt. Remove the front shock absorbers.

DO NOT REUSE ORIGINAL SHOCK ABSORBERS.

16) Carefully lower the front axle and remove the coil springs. Push down on axle if necessary.

⚠ WARNING: Do not allow the axle to hang by any hoses or cables. You could damage the hose or cable, without this damage being visible to you, resulting in sudden and unexpected failure and an accident.

CONTROL ARM REPLACEMENT

1) Adjust Rancho upper control arms to 20.3" (20-5/16") from center to center of mounting holes.

Note: Thread both ends fully into control arm and adjust by turning center tube while holding ends stationary. Upper control arm is adjustable without removing from the vehicle by turning center tube. Check tightness of jam nuts after 50 miles, then every oil change or when used off road.

2) Adjust Rancho lower control arms to 24.35" (24-3/8") from center to center of mounting sleeves.

TIP: Measure from edge to edge of sleeve See Illustration 6.

3) Raise axle up 4-5 inches.

⚠ WARNING: Perform next steps slowly and carefully to make sure axle does not twist off jack!

NOTE: Do not tighten control arm hardware until the end of the installation procedure. The upper front axle mount must be tightened with vehicle on the ground at ride height.

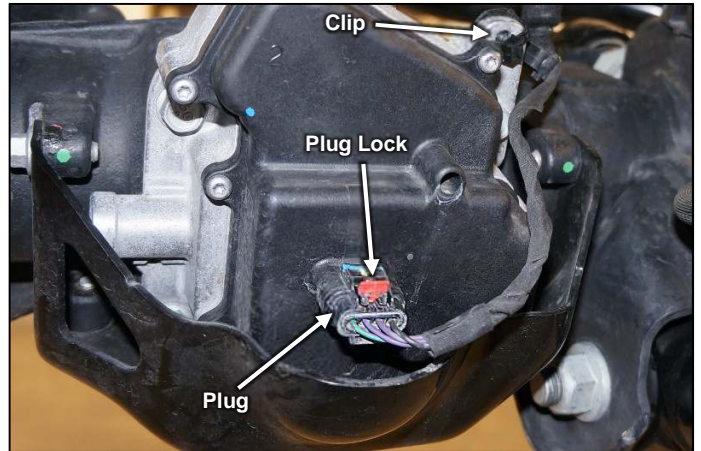

Illustration 4

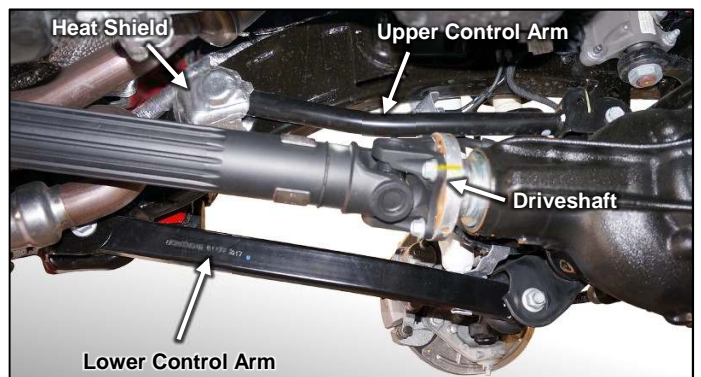

Illustration 5

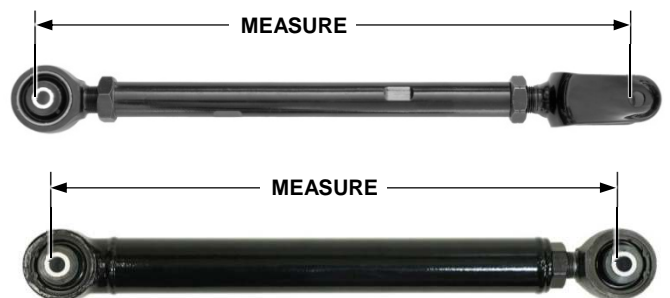

Illustration 6



Illustration 7

4) Remove the driver side upper control arm from the frame and axle brackets. If bolts are too tight to remove, raise axle until bolts spin with only a few pounds of torque, then remove.

5) Remove the driver side lower control arm from the frame and axle brackets.

6) Attach the bushing end of the upper control arm to the frame bracket with original. Attach clevis end of upper control arm to the axle bracket with the original hardware. See Illustration 7.

7) Attach the non-adjustable side of the lower control arm to the driver side axle bracket with the original hardware. The bend of the arm goes to the inside to provide clearance for tire. See Illustration 7.

8) Attach the adjustable end of the lower control arm to the frame bracket with original hardware.

9) If lower control arm cannot be lined up with mounting hole:

Support differential pinion with a jack and carefully disconnect the passenger side upper control arm from axle.

⚠ WARNING: Work slowly and carefully to make sure axle does not twist off jacks!

Use jack under pinion to align driver side upper lower arm with mount.

10) Repeat steps 5 through 9 to install control arms on the passenger side.

11) Torque lower arm mounting hardware to 190 lb-ft. Torque jam nut to 150 lb-ft.

12) Torque upper arm to frame bracket mounting hardware to 80 lb-ft. Torque jam nut to 150 lb-ft.

Do not tighten upper arm to axle mount bolts until vehicle is at normal ride height.

13) Re-install heat shields to upper control arm frame mounts.

BUMP STOP SPACER, COIL SPRING & SHOCK ABSORBER INSTALLATION

Front coils springs will need to be compressed to install. Use a quality spring compressor and follow manufacturer's instructions and warnings.

⚠ WARNING: a compressed coil spring is very dangerous. Be extremely careful; never stick your fingers, hands or other body parts anywhere that they may be pinched or smashed.

A sudden release of a compressed coil spring can result in injury or death!

1) Install original rubber isolator in driver side upper

coil mount. Align and insert the isolator's alignment pins in the holes in the upper mount.

2) Place 3" bump stop spacer inside the coil spring 869B-LF.

3) Compress coil spring 4".

4) Lower axle if required and insert the compressed spring with bump stop spacer into the upper pocket and onto the axle pad. Align pigtail with groove in axle pad. See Illustration 8.

⚠ WARNING: Do not allow the axle to hang by any hoses or cables. You could damage the hose or cable, without this damage being visible to you, resulting in sudden and unexpected failure and an accident.

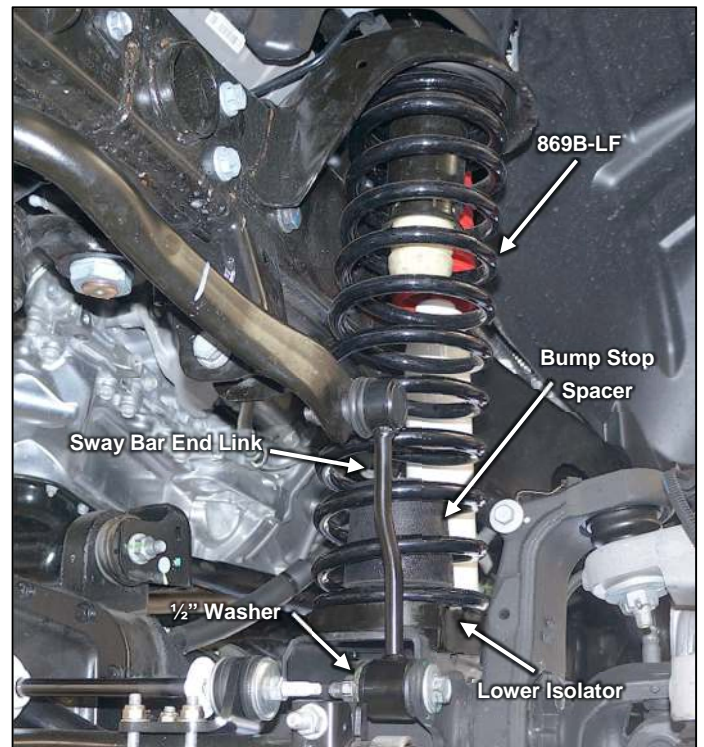

Illustration 8

5) Slowly release spring compressor and check for proper coil alignment.

6) Attach the bump stop spacer to the axle pad with supplied 9/16" hardware. Torque to 20 lb-ft.

7) Repeat steps 1 through 8 for the passenger side using spring 870B-RF.

To prevent shock bolt from contacting control arm in articulation, grind about 1/8" off end of bolt. See Illustration 9.

8) Install NEW Rancho shock absorber on the upper mount using OE bolt. Torque to 80 lb-ft.

9) Raise front axle and re-attach the brake line bracket to the axle using original hardware.

10) Attach shock lower mounts to axle brackets with the original hardware. Torque to 75 lb-ft.

11) Reattach drive shaft to pinion flange using OE hardware and blue Loctite. Torque to 81 lb-ft.

12)

13) Reattach vent hose and electrical wiring if necessary.

14) Attach brake line bracket to control arms using OE hardware. Bend brackets up slightly if needed to create slack in hose. See Illustration 9.

ADJUSTABLE TRACK BAR INSTALLATION.

1) Remove track bar axle mount nut & bolt, remove OE track bar.

2) Adjust Rancho track bar to 34.4 in. from center to center of mounting sleeves.

3) Attach adjustable end of track bar to axle mount using OE hardware. Torque bolt to 110 lb-ft.

NOTE: Frame end of track bar will be attached after lowering vehicle to ground.

SWAY BAR END LINK INSTALLATION.

End link ball stud and lower mounting bolt each use a different thread pitch. Be careful not to mix them!

1) Attach ball stud of new front end links to sway bar with the supplied nut. Torque to 60 lb-ft. See Illustration 8.

2) Attach passenger side end link to axle brackets with OE hardware.

3) Attach driver side end link to axle brackets with OE hardware and ½" USS washer from bag RS860874 between nut and end link. See Illustration 8.

4) Torque both end links to 60 lb-ft.

REMOVE BUMPER TRIM (IF REQUIRED)

Remove the bumper side trim if installing larger than 33" tires.

1) Remove the seven screws and one clip holding the trim to bumper. See Illustration 10 and Illustration 11.

2) Repeat for other side.

LOWER VEHICLE

1) With the suspension at maximum extension (full droop), inspect and rotate all axles and drive shafts. Check for binding and proper slip yoke insertion. The slip yoke should be inserted a minimum of one inch into the transfer case and/or transmission.

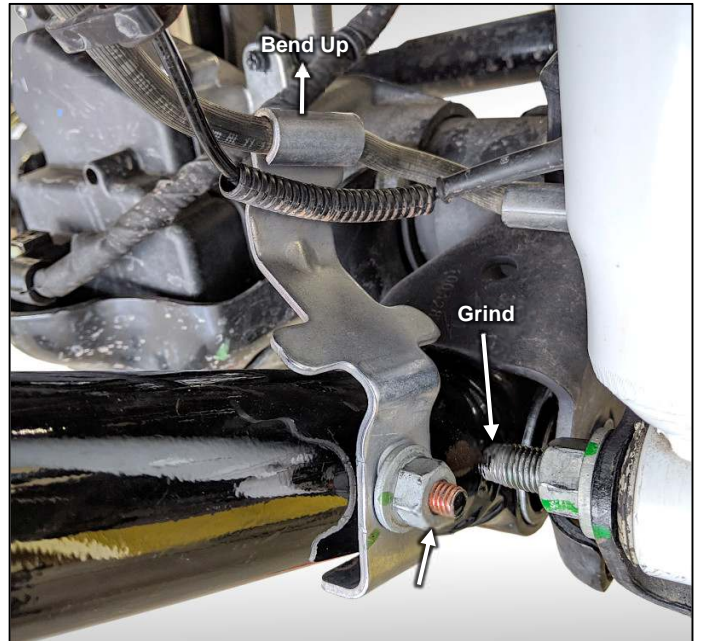

Illustration 9



Illustration 10

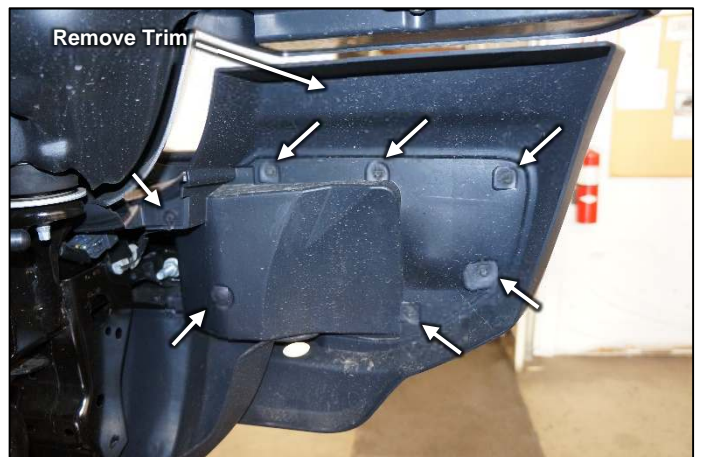

Illustration 11

- 2) Install front wheels and lower vehicle to the ground. Torque lug nuts to 130 lb-ft.
- 3) Torque upper control arm at axle mount to 80 lb-ft.
- 4) Attach track bar to frame mount using OE hardware.

Note: If track bar does not align with bracket, have an assistant slowly turn steering wheel to align holes.

- 5) Torque upper track bar bolt to 110 lb-ft. Torque Jam nut to 150 lb-ft.

REAR SUSPENSION

COIL SPRING REMOVAL

- 1) Park vehicle on a level surface. Set the parking brake and chock front wheels.
- 2) With vehicle on the ground, remove track bar bolt at axle. See Illustration 12.
- 3) Raise the rear of the vehicle and support the frame with jack stands. Remove the rear wheels.
- 4) Loosen, but do not remove, track bar bolt at frame.
- 5) Loosen, but do not remove, upper and lower control arm bolts at frame and axle. See Illustration 12.
- 6) Remove bolts and separate the ABS wire brackets from the axle. Unclip ABS wire from brake line and brake line bracket.
- 7) Remove the sway bar end links from frame mount.
- 8) Mark location of upper coil isolators to frame mount. See Illustration 13.
- 9) Support the rear axle with a floor jack.
- 10) Remove the shock absorbers at axle.
- 11) Remove the shock absorbers at frame
- 12) Carefully lower the rear axle until the coil springs are free from the upper mount seat.

Check any wires or hoses to make sure they are not pulled tight and damaged.

Take care not to over stretch and damage drive shaft boot.

⚠ WARNING: Do not allow the rear axle to hang by any hoses or cables. You could damage the hose or cable, without this damage being visible to you, resulting in sudden and unexpected failure and an accident.

- 13) Remove the coil springs

COIL SPRING INSTALLATION

- 1) Lower axle more to install new coil springs.

Check any wires or hoses to make sure they are not pull tight and damaged.

Take care not to over stretch and damage drive shaft boot.

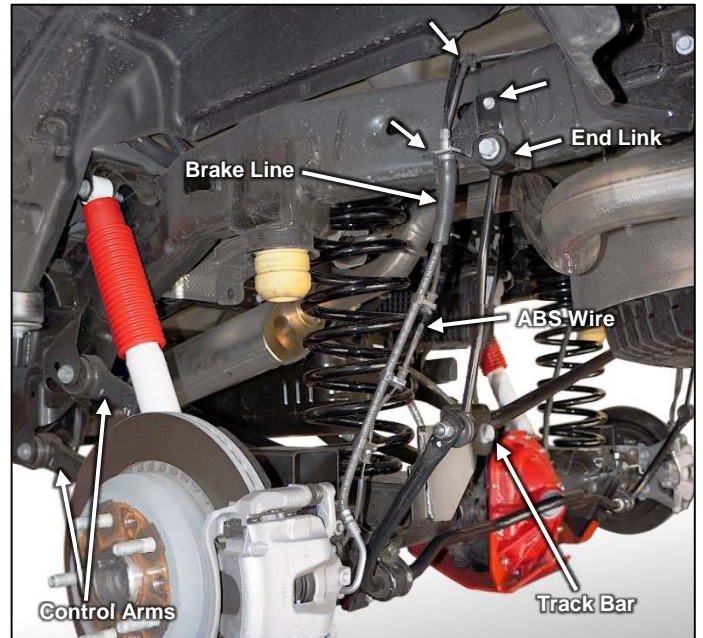

Illustration 12

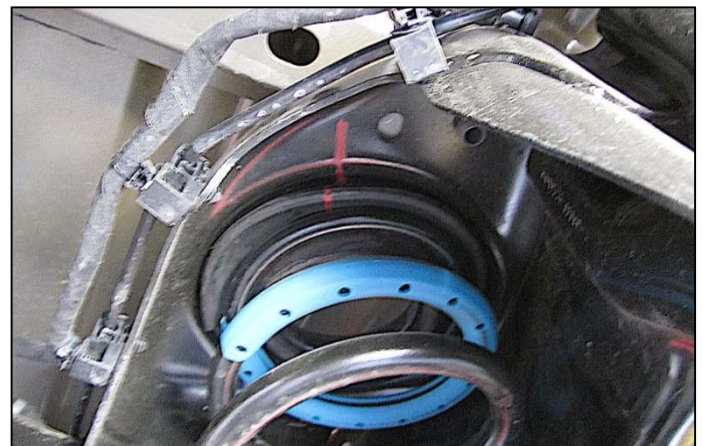

Illustration 13

⚠ WARNING: Do not allow the rear axle to hang by any hoses or cables. You could damage the hose or cable, without this damage being visible to you, resulting in sudden and unexpected failure and an accident.

- 2) Install new coils using OE isolators. Raise rear axle and make sure coils and isolators are seated properly.

Coils are side specific - RS881B Left, RS882B Right

Make sure locating pin of upper isolator in hole of upper mount and coil pigtail is seated in isolator. Use marks to help align isolators.

- 3) Install new Rancho shock absorbers to frame mount with OE hardware. Torque to 100 lb-ft.
- 4) Raise axle and attach shocks to axle mount using OE hardware. Torque to 100 lb-ft.
- 5) Install rear bump stop spacer RS176960 to axle pad using hardware from bag RS860830. The bump stop spacer fits with the longer slot to the front and the shorter slot to that rear. See Illustration 14 and Illustration 15.
- 6) With the suspension at maximum extension (full droop), inspect and rotate all axles and drive shafts. Check for binding and proper slip yoke insertion. Check for adequate length of any wires, hoses and links. Verify adequate tire, wheel, brake hose and ABS wire clearance. Inspect steering and suspension for tightness and proper operation.
- 7) Install wheels and lower vehicle to ground. Torque wheels to 130 lb-ft.
- 8) Install track bar and torque both ends to 120 lb-ft. If holes do not line up, have an assistant pull or push the body or frame to one side to align holes.
- 9) Torque upper and lower control arms to 190 lb-ft.
- 10) Repeat step 6 with suspension at ride height and full articulation.
- 11) Reconnect the negative ground cable to the battery

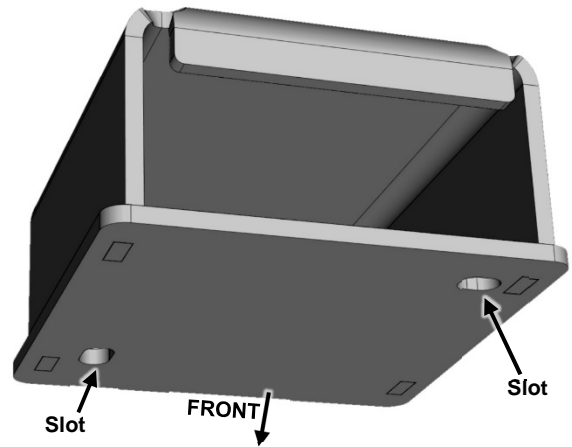

Illustration 14



Illustration 15

FINAL CHECKS & ADJUSTMENTS

- 1) Turn the front wheels completely left then right. Verify adequate tire, wheel, brake hose and ABS wire clearance. Inspect steering and suspension for tightness and proper operation.
- 2) Ensure that the vehicle brake system operates correctly. If new brake hoses were installed, verify that each hose allows for full suspension movement.

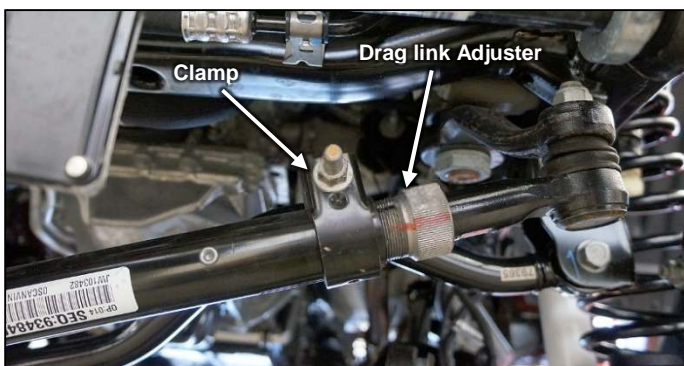

Illustration 16

- 3) Center steering wheel and axle.

Whenever track bar length is adjusted, the steering wheel must be centered to ensure that the ESP system operates correctly.

- Slowly (under 15 mph) drive vehicle 50-100 ft to settle suspension.
 - If front axle needs to be centered, remove track bar adjustable end and adjust length by HALF the amount axle is off center.
 - Reattach track bar and torque to 110 lb-ft. Torque Jam nut to 150 lb-ft.
 - To center the steering wheel, loosen drag link adjuster clamp and turn the drag link adjuster in desired direction. Torque clamp bolt to 26 lb-ft. See Illustration 16.
- 4) Readjust headlamps.

5) Have vehicle aligned to manufacturer's specifications.

Alignment Specifications:

Caster	4.8° ± 1.0°
Camber (fixed angle)	-0.25° ± 0.37°
Toe-In, Each Wheel	0.0° – 0.12°
Toe-In, Total	0.0° – 0.20°
Thrust Angle	0° - 0.20°

6) Park the vehicle on a level surface. Measure and record the distance from the center of each wheel to the top of the fender opening. See Illustration 17.

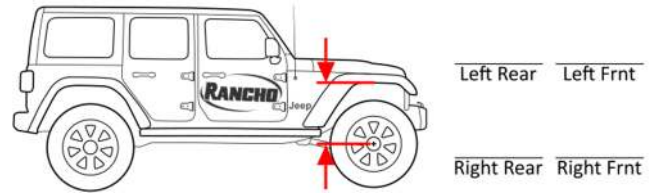

Illustration 17

⚠ WARNING:

Periodically check tightness of all components.
Check tightness of control arm and track bar jam nuts after 50 miles, then every oil change or after driving off-road.

Torque Specs

Front Components

Upper Control Arm	80 lb-ft
Lower Control Arm	190 lb-ft
Control Arm Adjuster Jam Nut	150 lb-ft
Front Bump Stop Spacer	20 lb-ft
Shock Absorber Upper Mount	80 lb-ft
Shock Absorber Lower Mount	75 lb-ft
Front Drive Shaft to Pinion Flange	81 lb-ft
Sway Bar End Link	60 lb-ft
Track Bar	110 lb-ft
Track Bar Jam Nut	150 lb-ft
Drag Link Adjustment Sleeve Clamp	26 lb-ft
Wheels (Lug Nuts)	130 lb-ft.

Rear Components

Upper Control Arm	190 lb-ft
Lower Control Arm	190 lb-ft
Rear Bump Stop Spacer	20 lb-ft
Shock Absorber Upper Mount	100 lb-ft
Shock Absorber Lower Mount	100 lb-ft
Track Bar	120 lb-ft
Sway Bar End Link	55 lb-ft
Wheels (Lug Nuts)	130 lb-ft

STANDARD BOLT TORQUE & IDENTIFICATION

INCH SYSTEM			METRIC SYSTEM			
Bolt Size	Grade 5	Grade 8	Bolt Size	Class 8.8	Class 10.9	Class 12.9
5/16	15 LB-FT	20 LB-FT	M6	5 LB-FT	9 LB-FT	12 LB-FT
3/8	30 LB-FT	35 LB-FT	M8	18 LB-FT	23 LB-FT	27 LB-FT
7/16	45 LB-FT	60 LB-FT	M10	32 LB-FT	45 LB-FT	50 LB-FT
1/2	65 LB-FT	90 LB-FT	M12	55 LB-FT	75 LB-FT	90 LB-FT
9/16	95 LB-FT	130 LB-FT	M14	85 LB-FT	120 LB-FT	145 LB-FT
5/8	135 LB-FT	175 LB-FT	M16	130 LB-FT	165 LB-FT	210 LB-FT
3/4	185 LB-FT	280 LB-FT	M18	170 LB-FT	240 LB-FT	290 LB-FT

1/2-13x1.75 HHCS

D T L X

G = Grade Marking (bolt strength) L = Length (inches)
D = Nominal Diameter (inches) X = Description (hex head cap screw)
T = Thread Pitch (threads per inch)

M12-1.25x50 HHCS

D T L X

P = Property Class (bolt strength) L = Length (millimeters)
D = Nominal Diameter (millimeters) X = Description (hex head cap screw)
T = Thread Pitch (thread width, mm)



www.gorancho.com

Rancho Technical Department 1-800-325-8886.