

GT
MOMENTUM™

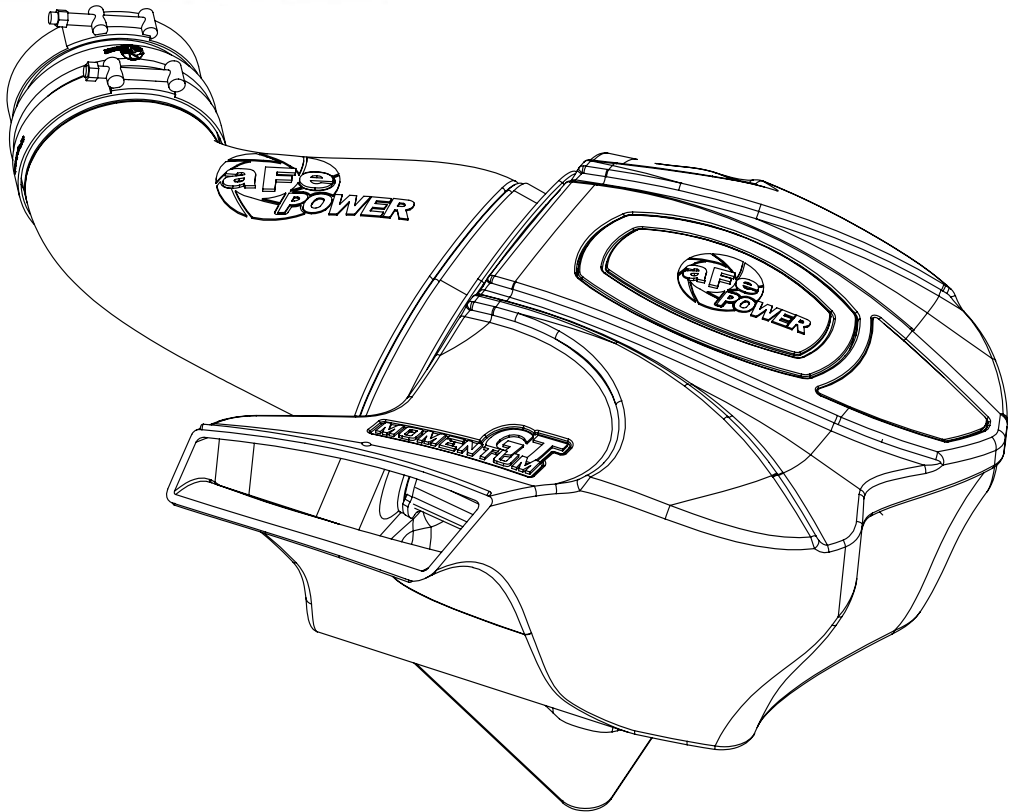

advanced FLOW engineering Momentum GT Cold Air Intake System

Instruction Manual P/N: 51-76206-1 / 54-76206-1

Make: **Jeep** Model: **Grand Cherokee (WK2) SRT-8/SRT** Year: **2012-2019** Engine: **V8-6.4L HEMI**
Make: **Dodge** Model: **Durango SRT** Year: **2018-2019** Engine: **V8-6.4L HEMI**



- Please read the entire instruction manual before proceeding.
- Ensure all components listed are present.
- If you are missing any of the components, call customer support at 951-493-7100.
- Ensure you have all necessary tools before proceeding.
- Do not attempt to work on your vehicle when the engine is hot.
- Disconnect the negative battery terminal before proceeding.
- Retain factory parts for future use.

Label	Qty.	Description	Part Number
A1	1	Air Filter (Pro 5R)	24-91101
A2	1	Air Filter (Pro DRY S)	21-91101
B	1	Tube	05-76206B1
C	1	Housing	05-76206B2
D	1	Clamp, T-Bolt (4-1/8" - 4-1/2")	03-50262
E	1	Coupling, Silicone Hump	05-01386
F	1	Clamp, T-Bolt (3-9/16" - 3-7/8")	03-50498
G	1	Grommet, Air Temp Sensor	03-50167
H	1	Hose, Fuel: 5/8" (7")	05-00069
I	1	Fitting Air Temp Sensor	05-01454
J	1	Clamp, Mini	03-50078

Tools Needed: 8mm nut driver, 10mm nut driver, 10mm deep socket, 1/4" ratchet, flat head screw driver.

Recommended: Panel clip pliers or panel popper, silicone lubricant.

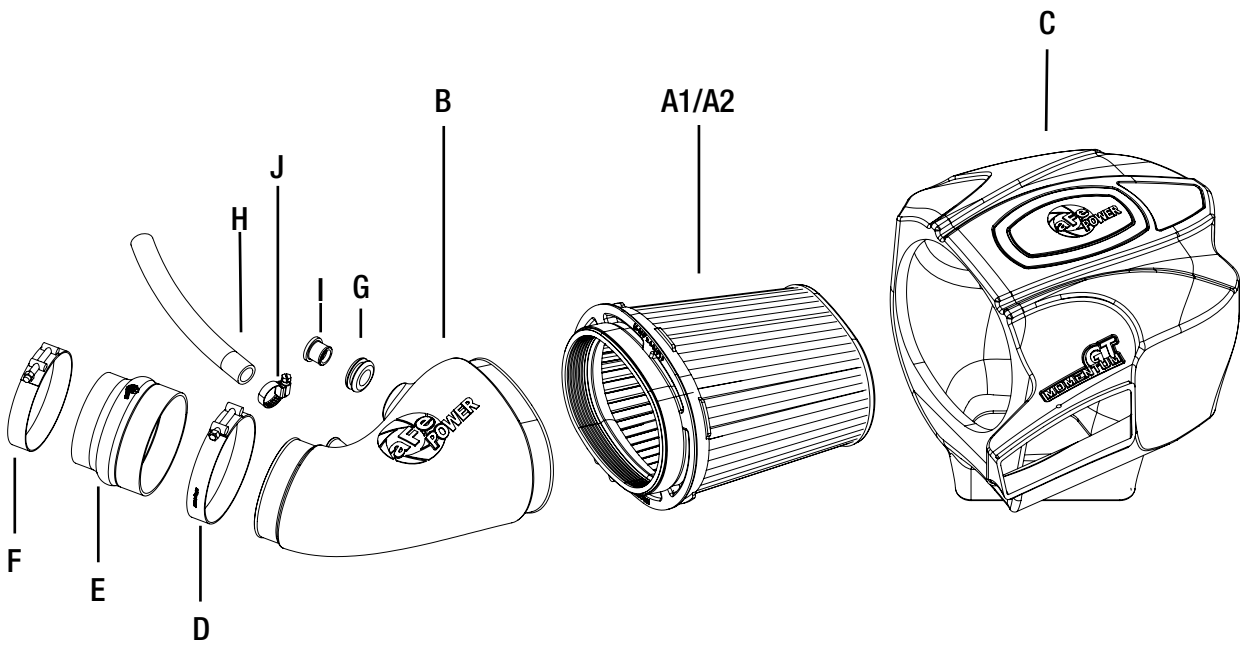



Refer to Figure A for Step 1

Step 1: Remove engine cover trim (1). Removal of the oil cap may be necessary.



Figure B

Refer to Figure B for Steps 2-5

Step 2: Disconnect the temperature sensor harness (2) from the OE intake tube.

Step 3: Disconnect the Crank Case Vent (CCV) hose (3) from the engine valve cover.

Step 4: Using an 8mm nut driver, loosen the clamp (4) at the throttle body end of the OE tube.

Step 5: Lift and remove the entire intake assembly at this time.



Refer to Figure C for Steps 6-8

Step 6: Pull back the factory rubber trim seal (5) to where you can see a green plastic push clip, as shown in the inset picture.

Step 7: Using panel clip pliers (recommended), carefully remove the trim from the plastic block off plate.

*Take care not to damage these clips as they will be reinstalled.

Step 8: Remove 2-3 clips on either side of the center.

**Figure D****Refer to Figure D for Steps 9-11**

Step 9: First pull the center of the black plastic push clips up (6) as shown.

Step 10: Then carefully remove each push clip.

Step 11: Lift and remove the plastic block off plate.



Figure E

Refer to Figure E for Steps 12-14

- Step 12: Partially pull the plastic liner up so the wire shown ⑦ can be tucked behind.
- Step 13: Tuck the wire below the plastic intake mounting stud as shown in the inset picture.
- Step 14: Place the plastic liner back in its original position.



Figure F

Refer to Figure F for Step 15

Step 15: Using the provided rubber hose, connect one end to the engine Crank Case Vent (CCV) fitting

⑧ as shown.

Note: It may help to apply a small amount of lubricant on the inside of the rubber hose to slip over the CCV fitting.

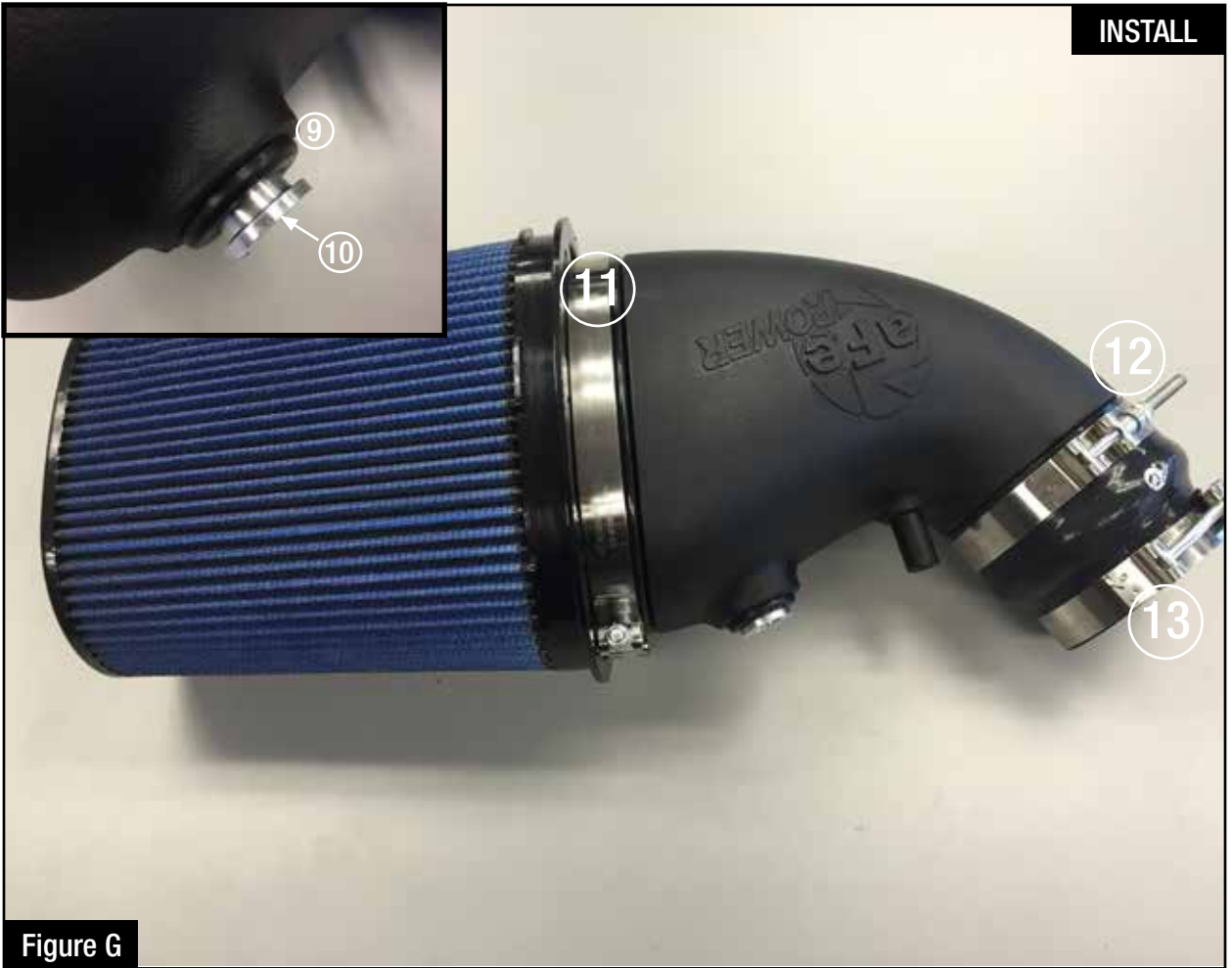

Figure G

Refer to Figure G for Steps 16-21

Step 16: Insert the provided rubber grommet (9) into the tube.

Step 17: Press the aluminum temperature sensor fitting (10) into the rubber grommet.

Note: A small amount of lubricant on the inside of the rubber grommet may help hose to slip over the CCV fitting.

Step 18: Insert the rotomold tube into the filter (11) until there is no gap between them.

Step 19: Slide the reducer hump coupling over the tube as shown (12), followed by the larger 03-50262 T-bolt clamp.

Step 20: Position the clamp as shown in the photot and then tighten the 03-50262 T-bolt clamp at this time.

Step 21: Slide the smaller 03-50498 T-bolt clamp over the coupling (13) but, do not tighten at this time.

**Figure H****Refer to Figure H for Step 22**

Step 22: Insert the tube/filter assembly into the housing (14) as shown. Press until you feel or hear all 6 of the tabs seat themselves in the housing. Gently pull on the tube to verify is properly seated.

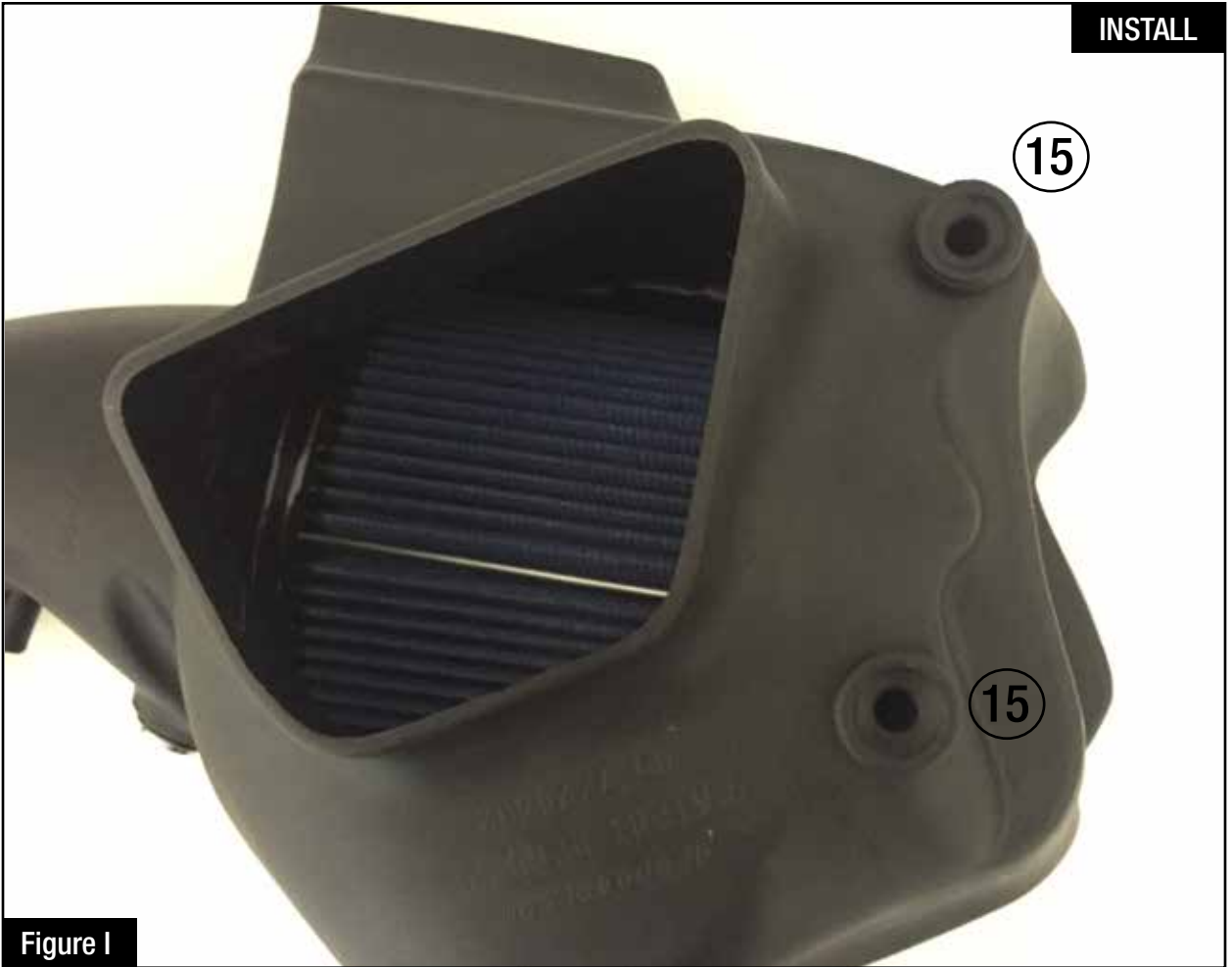

Figure I

Refer to Figure I for Step 23

Step 23: Remove 2 of the 3 grommets from the bottom of the OE housing and insert in the bottom of the aFe rotomold housing (15) as shown above.



Figure J

Refer to Figure J for Steps 24-28

Step 24: While holding the intake assembly; first slide the coupling over the throttle body, then compress the silicone coupling and lower the intake onto the OE mounting locations. Press down firmly to securely seat the housing.

Step 25: Attach the other end of the CCV hose to the aFe tube (16).

Note: Optional Mini clamp provided for use over hose if needed.

Step 26: Insert the OE temp sensor into the the aluminum fitting and secure by turning clockwise. (17)

Step 27: Reconnect the temperature sensor wiring harness.

Step 28: Reinstall rubber trim seal into the factory locations and into the aFe housing (18).



Figure K

Refer to Figure K for Steps 29-30

Step 29. Align tube where there are no gaps and tighten all clamps.

NOTE: Notice the cutout on the bottom of the intake tube...on some vehicles the AC line may need to be moved to give more clearance under the tube and fit in this area. Do this by gently moving the line left or right through its mounting bushing ①9.

Step 30. Reinstall engine cover. Your installation is now complete.

NOTE: Place enclosed CARB EO sticker on or near the device on a smooth/clean surface. EO identification label is required to pass the smog test inspection.

Pro DRY S Air Filter



P/N: 21-91101

Pro 5R Air Filter



P/N: 24-91101

Pro DRY S Restore Kit



P/N: 90-59999

Blue Squeeze Restore Kit



P/N: 90-50501

Cat-Back Exhaust



P/N: 49-38058 (No Reson.)
49-38059 (w/ Reson.)

Long Tube Headers



P/N: 48-36211-YC (Street)

Sprint Booster V3



P/N: 77-16204

To purchase any of the items above, view airflow charts, dyno graphs, photos, and video; please go to aFepower.com.



Page left blank intentionally.

Page left blank intentionally.



Page left blank intentionally.

Warranty

General Terms:

- aFe warrants their products to be free from manufacturer's defects due to workmanship and material.
- This warranty applies only to the original purchaser of the product and is nontransferable.
- Proof of purchase of the aFe product is required for all warranty claims.
- Warranty is valid provided aFe instructions for installation and/or cleaning were properly followed.
- Proper maintenance with regular inspections of product is required to insure warranty coverage.
- Damage due to improper installation, abuse, unauthorized repair or alteration is not warranted.
- Incidental or consequential damages or cost, including installation and removal of part, incurred due to failure of aFe product is not covered under this warranty.
- All warranty is limited to the repair and/or replacement of the aFe part. To request Return Goods Authorization ("RGA"), email RGA@afepower.com or call (951)493-7100. Upon receipt of the RGA, you must return the product to the address provided in the RGA, freight prepaid and accompanied with a dated proof of purchase and the RGA. Upon receipt of the defective product and upon verification of proof of purchase, aFe will either repair or replace the defective product within a reasonable time, not to exceed thirty days.

Product Category	P/N Prefix	Warranty duration
Direct OE Replacement Filters	10, 11, 30, 31, 71, 73	Life of the vehicle
Racing Filters	18	1 year
Universal	21, 24, 72	2 years
Air Intake Systems	50, 51, 54, 55, 75	2 years
Exhaust Systems	49	2 years
Intercoolers & Intercooler Tubes	46-2	2 years
Intake Manifolds	46-1	2 years
Differential Cover	46-7	Life of the vehicle
Exhaust Manifolds	46	2 years
Throttle Body Spacers	46-3	2 years
Fluid Filters	44	90 days
Pre-Filters	28	2 years
Heavy Duty OE Replacement	70	2 years
PowerSports OE Replacement	81, 87	2 years
PowerSports Intake Systems	85	2 years

No other warranty expressed or implied applies nor is any person or advanced FLOW engineering authorized to assume any other warranty. Some States do not allow the exclusion or limitation of incidental or consequential damages or do not allow limitations on how long an implied warranty lasts, so the above limitations or exclusions may not apply to you. This warranty gives you specific legal rights, and you may also have other rights which vary from State to State.

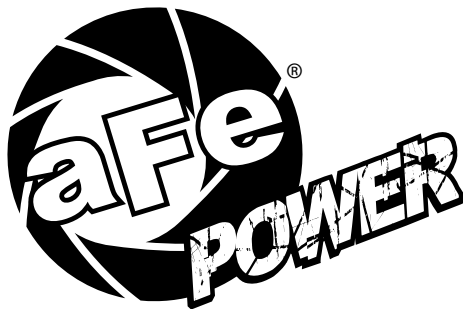

advanced FLOW engineering, inc.

252 Granite Street Corona, CA 92879

TEL: 951.493.7100 • TECH: 951.493.7134