

MAGNUSON

SUPERCHARGERS

Installation Instructions for:
2012 + Jeep Wrangler 3.6L V-6
INTERCOOLED SUPERCHARGER SYSTEM



PREMIUM GASOLINE FUEL REQUIRED

ATTENTION!

Your MAGNUSON SUPERCHARGER kit
is sensitive to corrosion!



Use only the vehicle manufacturer
recommended coolant for your engine
in the intercooler system as well.

Magnuson Superchargers
1990 Knoll Drive, Bldg A, Ventura, CA 93003
(805) 642-8833
magnusonsuperchargers.com

Magnuson Supercharger Kit JEEP Wrangler 3.6L V-6 Engine

Please take a few moments to review this manual thoroughly before you begin work: Make a quick parts check to make certain your kit is complete (see shipper parts list in this package). If you discover shipping damage or shortage, please call your dealer immediately. Take a look at exactly what you are going to need in terms of tools, time, and experience. Review our limited warranty with care. When unpacking the supercharger kit **DO NOT** lift the supercharger assembly by the black plastic bypass actuator. This is pre-set from the factory and can be altered if used as a lifting point!

Caution: Relieve the fuel system pressure before servicing fuel system components in order to reduce the risk of fire and personal injury. After relieving the system pressure, a small amount of fuel may be released when servicing the fuel lines or connections. In order to reduce the risk of personal injury, cover the regulator and fuel line fittings with a shop towel before disconnecting. This will catch any fuel that may leak out. Place the towel in an approved container when the job is complete.

Use only premium gasoline fuel, 91 octane or better.

Magnuson Superchargers recommend that you run a minimum of one (1) tank of premium fuel through your vehicle prior to installation of the system to prevent any possible damage that may occur due to running the supercharged engine on lower octane fuel.

Magnuson Superchargers systems are designed for engines and vehicles in “GOOD” mechanical condition. Magnuson Superchargers recommend that a basic engine system “Health Check” be performed prior to the installation of this supercharger system. Be sure to check for any pending or actual OBDII codes and fix/repair any of the stock systems/components causing these codes. If there are codes prior to the installation they will be there after the installation.

Magnuson Superchargers also recommend the following services to be performed on your vehicle before starting and running the vehicle post supercharger system installation:

- Fuel Filter change
- Engine oil and oil filter change using brand name oil (organic or synthetic) and filter
NOTE: 2012-2013 Model year kits come with cleanable 2-stage oil filter elements.

Note: It is **VERY IMPORTANT** to use the factory specified oil viscosity. The original equipment manufacturer has selected this grade of oil to work with your other engine systems such as hydraulic chain tensioners and variable cam controls. Deviation from this specification may cause these systems to fail or not function properly. Please refer to your owner’s manual for the recommended oil viscosity for your engine and application.

- On newer vehicles not requiring new spark plugs it is important to verify the spark plug air gap.

On older vehicles Magnuson Superchargers recommend these additional services to be performed:

- New stock spark plugs with the air gap set at the factory specifications OR new specifications if required by the installation manual.
- Coolant system pressure test, flush and refill. **NOTE: YOU MUST USE JEEP SPECIFIED COOLANT MIX-TURE!**

WARNING: Non “Magnuson Approved” calibrations or “tuning” will Void ALL warranties and CARB certification.

Safety glasses

Stock spark plugs and stock plug gap is recommended

Drive belt = Gates K061120 **NOTE: High altitude kits come with smaller pulley and Gates K06115 belt.**

Tools Required:

Metric wrench set

¼” - 3/8” and ½” drive metric socket set (Standard & Deep)

3/8” and ½” drive Foot pound and inch pound torque wrenches

Phillips and flat head screwdrivers

Hose cutters, Tree Clip Removal Tool

Hose Clamp pliers, Telescoping Magnet

Metric Allen socket set 3/8” drive

Shop vacuum cleaner

Blue Loctite 242

A photograph of a Jeep JK driving on a dirt road in a desert landscape. The Jeep is in the foreground, moving towards the right, with its front end and wheels visible. The background shows rolling hills and mountains under a clear sky. The text is overlaid on the image.

ATTENTION

Prior to installing this supercharger kit, there are several things to be aware of regarding how your Jeep JK calculates transmission shift points, and procedures to follow to ensure that your Jeep shifts correctly.

The Jeep JK engine controller (ECU) uses the vehicle wheel speed to calculate transmission shift points and tell the Transmission Control Module (TCM) when to shift. There is currently no aftermarket programmer or controller that allows access to the Jeep JK TCM. If you have changed your wheel and tire sizes, you must do the following:

- If you have installed larger wheels and tires, we highly recommend you also install new gearing to maintain the factory drive ratio. If you increase tire size, you will need a lower gear (numerically higher). There are several calculators and charts available online that can guide you in choosing the correct gear ratio for your tire size
- If you have used an aftermarket programmer, such as an AEV ProCal, a Diablo tuner, or Superchips, to adjust for your larger tire size prior to installing your supercharger, you must set your calibration back to stock before applying the supplied Magnuson tune. You can then either adjust the wheel and tire size using an AEV Procal device. If you apply the tire-size adjustment without first removing the previous tune, it will stack the tire calibration. The vehicle will think it will have much larger tires than it does, and the transmission shift points will be incorrect. If in doubt, contact the shop that installed the wheels and tires, and find out how they calibrated the ECU for the larger tires

Also be aware that the Jeep JK transmission has a tendency to hang onto gears, especially under load. Larger wheels and tires, adding weight such as vehicle accessories or heavier bumpers, driving up grades, towing a trailer, or driving at wide-open throttle may cause the transmission to hang in gear and take longer to shift than you would expect. There is currently no fix for this, or any modifications we can make to the ECU to correct this. There are a few workarounds, however, such as using the manual shift mode, or lifting off the throttle slightly.

NOTES: For the purpose of these instructions, all references to left hand side or right hand side shall be interpreted as if being seated in the driver seat of the vehicle.

1. Prior to beginning the installation of your supercharger system we recommend that you schedule your vehicle at the dealership to have the most recent stock calibration loaded. This **MUST** be done before proceeding any further.



2. Open up the supplied programmer package and follow the instructions for programming the vehicle prior to disconnecting the battery and beginning the installation of the supercharger system. This **MUST** be done before proceeding any further to insure that you have all the benefits of the latest level of updated software from the manufacturer. The handheld tuner may not look like the one shown.



3. Your supercharger system is sensitive to corrosion. Use only the OEM recommended coolant mixture for your supercharger system as well as your engine.



4. It is **IMPORTANT** to utilize **91 Octane** gasoline or better with your supercharger system. Before starting this installation, on an empty tank, fill your tank to full with 91 Octane gasoline or better. Never add Octane booster to your fuel. If you have used Octane Booster in the past, replace your spark plugs and check your O2 sensor before completing your supercharger install.



5. Remove the gas cap to relieve gas tank pressure.



6. Locate the fuse box in the engine bay.



7. Remove the # 37 - 10A fuse labeled "ABS, Fuel Pump Relay, Sway Bar" using the fuse removal tool in the fuse box.



8. Start your vehicle to bleed off any residual pressure in your fuel line, run the vehicle until it dies, then try to start a couple more times just to be sure there is no more pressure in the fuel line.



9. Remove the negative battery terminal using a 10mm wrench. Slide the battery cable out of the way and apply some insulation material like tape to it so that it cannot make accidental contact with the battery terminal.



10. Pull up on the engine cover to remove from the vehicle. This will not be reused but you may want to have these parts available to return to factory condition.



11. **NOTE: For model years 2012-2013 follow the next 6 oil filter steps. For model years 2014+ skip these steps.** Use a 24mm socket to loosen the oil filter casing lid. This is spring loaded, and loosening the cap allows the oil to drain down into the engine from the filter. **NOTE: Model years 2012-13 see additional note at end of instructions.**



12. After a couple of minutes, pull up on the casing and remove the existing filter element which will be snapped into the cap.



13. Pull the cap off the OEM filter element.



14. This shows the provided new two piece filter element orientation. **Notice that the element with no extrusion has an attached rubber gasket.** This gasket points up and rests between the two halves of the split filter. The other element has the extrusion pointed up.



15. Place a thin film of new oil on the lower filter element gasket and slide into the oil filter casing on the engine with the gasket pointing up.



16. The upper filter element with the extrusion gets pressed into the oil filter casing cap with the extrusion going into the cap. This will “snap” into place holding the element to the cap.



17. Replace the oil filter casing cap onto the filter housing and torque to 18 ft-lbs using a 24mm socket.



18. Use a tree clip removal tool to remove the two tree connectors that hold the manifold insulation to the back of the upper intake manifold.

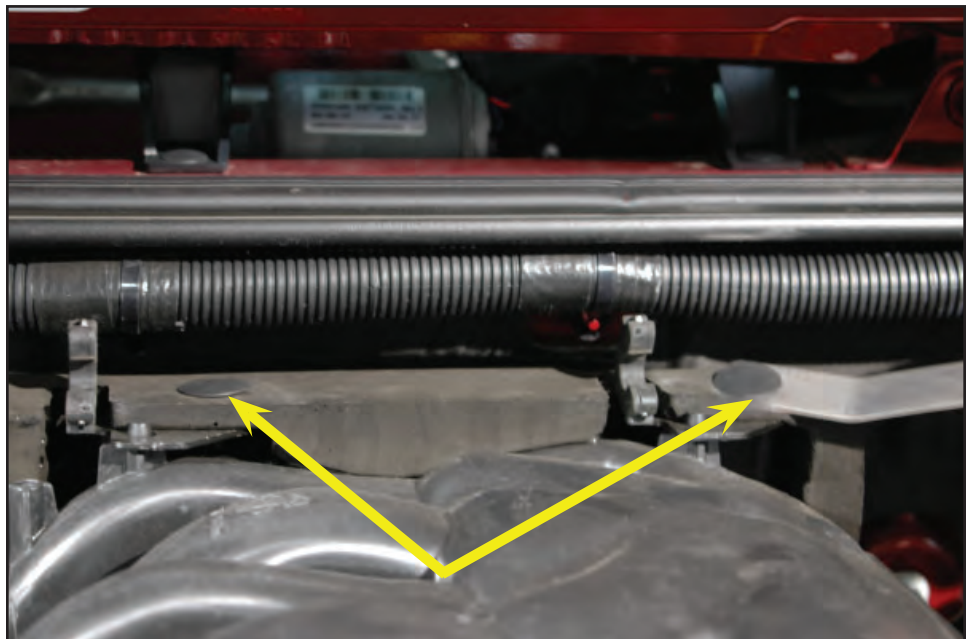

19. Use a 10mm wrench to remove the two plastic fasteners and brackets below the manifold insulation at the back of the upper intake manifold. Remove these brackets.



20. Pull the insulation away from the manifold.



21. Disconnect the windshield washer tube from its connector on the left side of the firewall



22. We found it easiest to install the supercharger with the hood resting against the roof. Carefully lift the hood back against the top of the window frame. Using the insulation removed two steps ago as a buffer between the hood and the roof as shown



23. Pull the radiator overflow hose from the clamps at the front of the air intake tube. Use a 10mm socket to remove the two air box mounting fasteners.



24. Use an 8mm socket to loosen the throttle body mounting clamp at the air tube to throttle body connection.



25. Use an 8mm socket to loosen the air tube mounting clamp at the air box.



26. Disconnect the IAT electrical connection leaving the OEM IAT sensor in place.

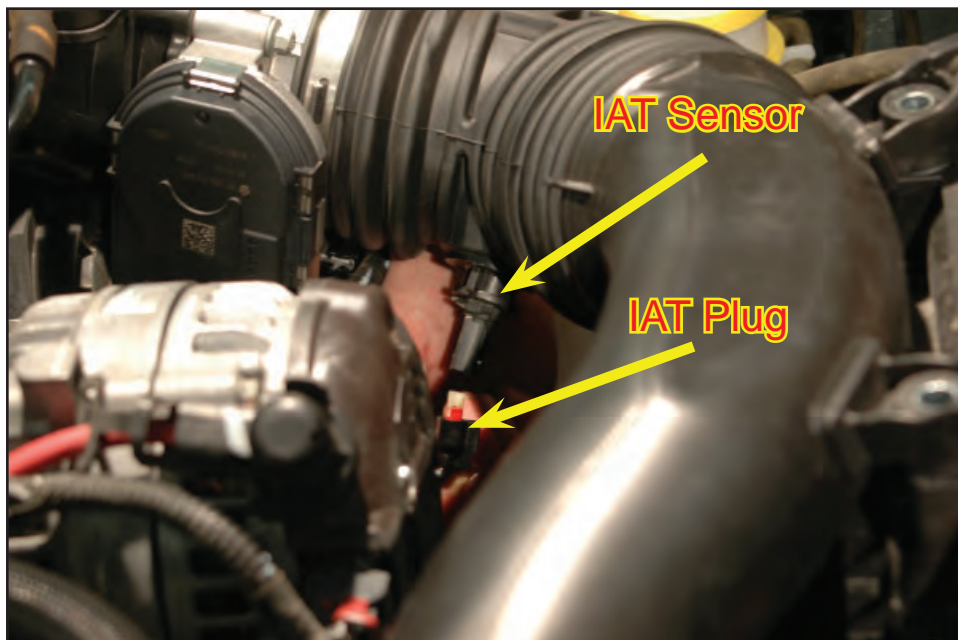

27. Carefully pull the air tube off the throttle body and air box. Set aside for later reinstall.



28. Pull the vacuum hose from the side wall hose barb on the air box.



29. Pull up on the air box to remove the assembly from the vehicle. Set aside for later reinstall.



30. Disconnect the harness clip from the tab/boss on the throttle body. Pull out on the red throttle body control locking pin, and then press down on the exposed end to release the plug from the throttle body.

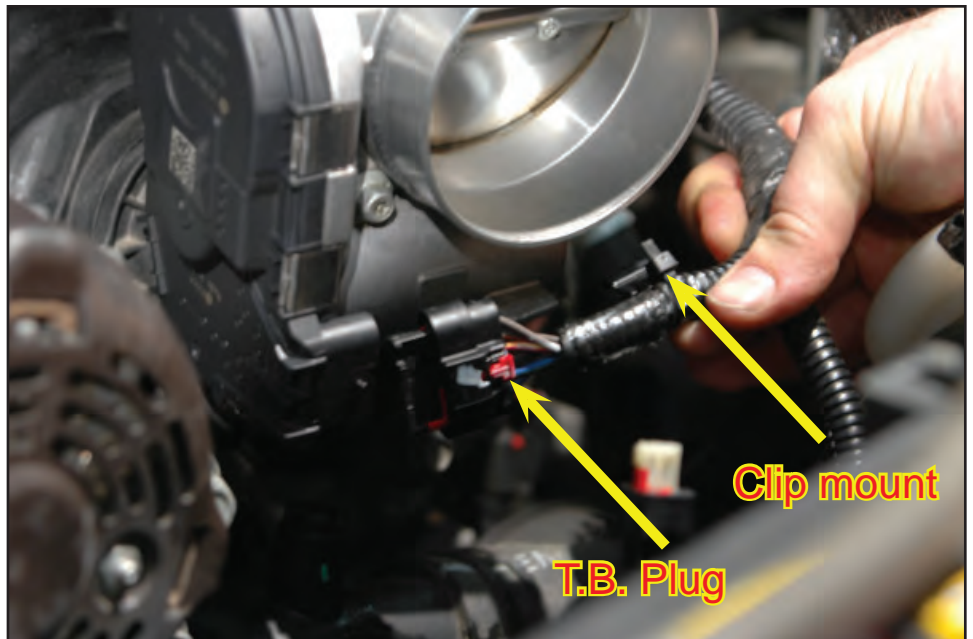

31. Use an 8mm socket to remove the four throttle body mounting bolts. Carefully wipe the throttle body clean and store in a safe place for reinstallation later during the supercharger the install.



32. Use a tree clip removal tool to remove the tree connector holding the wire harness to the left side-upper intake manifold connector near the throttle body mounting location.



33. Disconnect the Manifold Absolute Pressure (MAP) sensor from the left side upper intake manifold, near the throttle body mounting location by pressing the release tab and pulling free.



34. Remove the harness mounting "tree" clip from the forward, upper intake manifold mounting bracket.

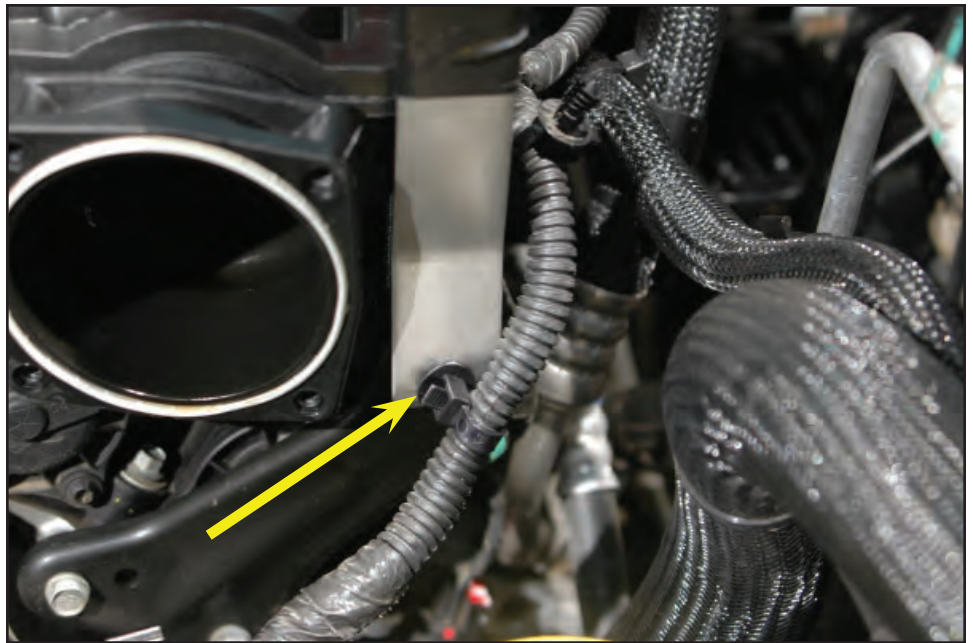

35. Remove the harness mounting "tree" clip from the back of the upper intake manifold mounting bracket.



36. Use a 10mm wrench to remove the four upper intake manifold mounting bracket fasteners from the left hand side of the engine. Two are at the forward bracket and two are at the rear bracket.

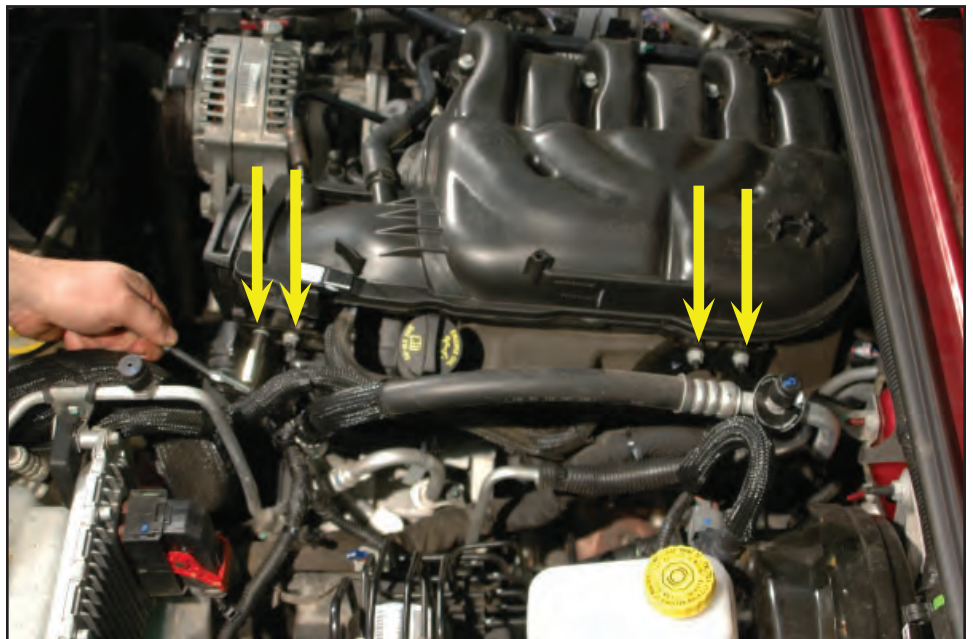

37. Use a 10mm socket to remove the two bolts holding the mounting bracket to the front of the engine on the left hand side. Pull the bracket out of the engine and set aside, this will not be reused. Again put this part aside if you intend to ever return your vehicle to factory condition.



38. Pull the EVAP hose and the PCV hose off the hose barbs on the front-right side of the upper intake manifold.

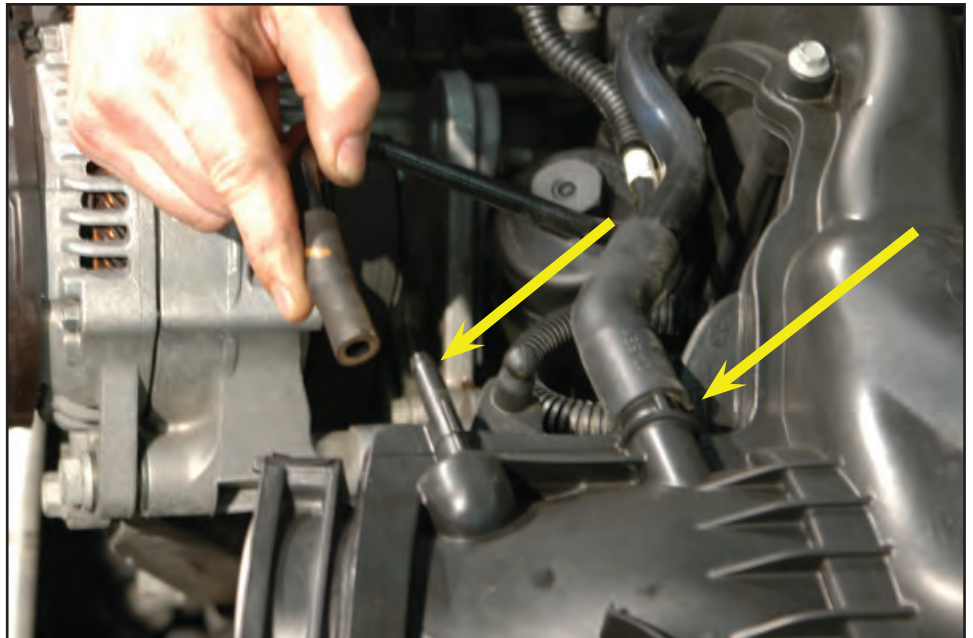

39. Pull the brake booster vacuum hose from the front-left side of the upper intake manifold.



40. Disconnect the vacuum tubes on the right side of the upper intake manifold from their molded retaining slots.



41. Remove the PCV vacuum tubes connected to the back of the valve covers from the vehicle. The left hand side PCV tube will be reused and components of the right hand side PCV tube will be reused. If it's difficult at this time to remove the tubes completely, it's helpful to tuck the tubes up out of the way by securing to the cross deck wiring harness using the provided zip ties.



42. Using the tree clip removal tool carefully pry up on the base of the right hand side main wiring harness connector to release the two mounting tree clips from the bracket below.



43. Use a 10mm socket to remove the fasteners holding the right hand side heater tube/wiring harness bracket to the engine. Two bolts are closest to the intake manifold, two nuts are holding the heater tubes to the bracket, and two other nuts are near the base of the valve cover, between the battery-box and where the bracket bends down toward the exhaust manifold. (see next step)

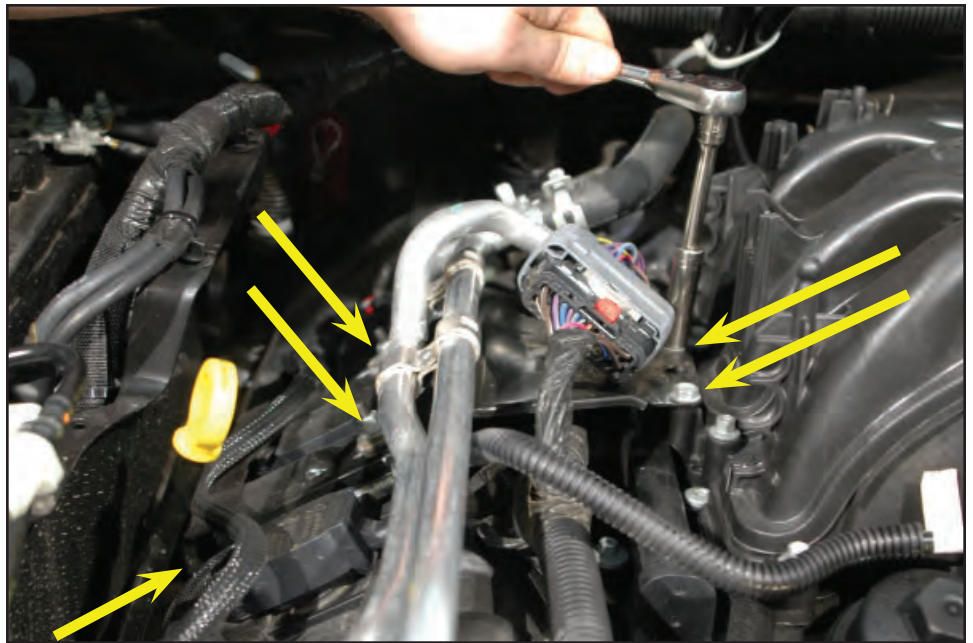

44. This picture shows the engine out of a vehicle for clarity and illustrates the location of the two lowest bracket mounting nuts.

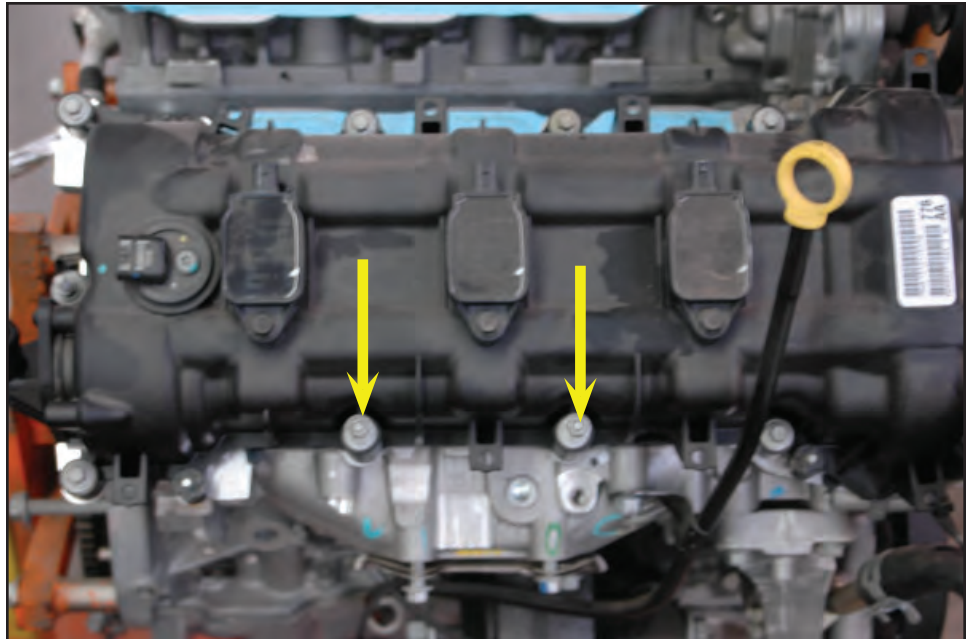

45. Carefully remove the tree clip from the rear of the bracket using a tree clip removal tool.

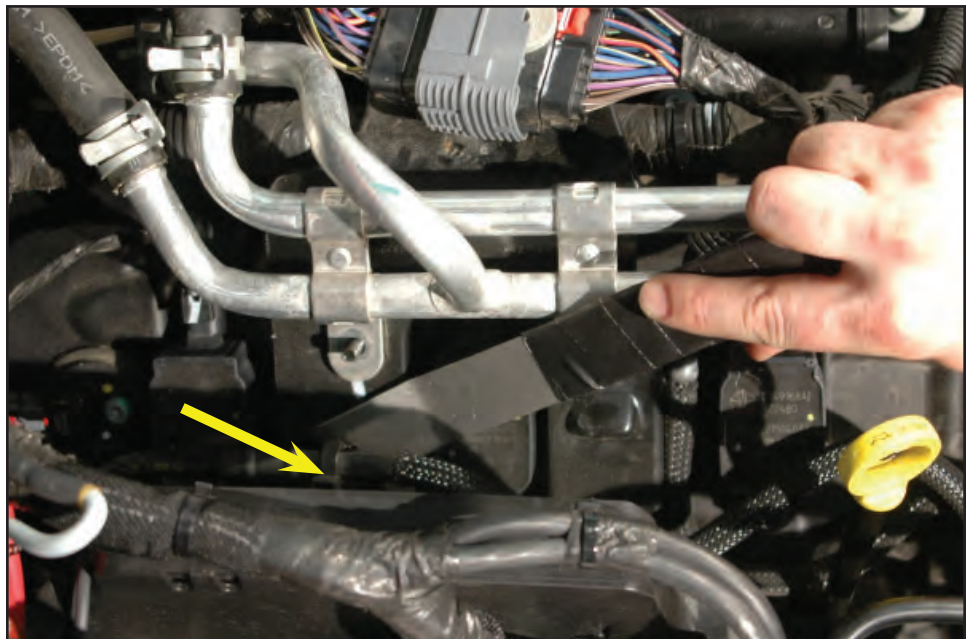

46. Carefully remove the tree clip from the front edge of the bracket using a tree clip removal tool.

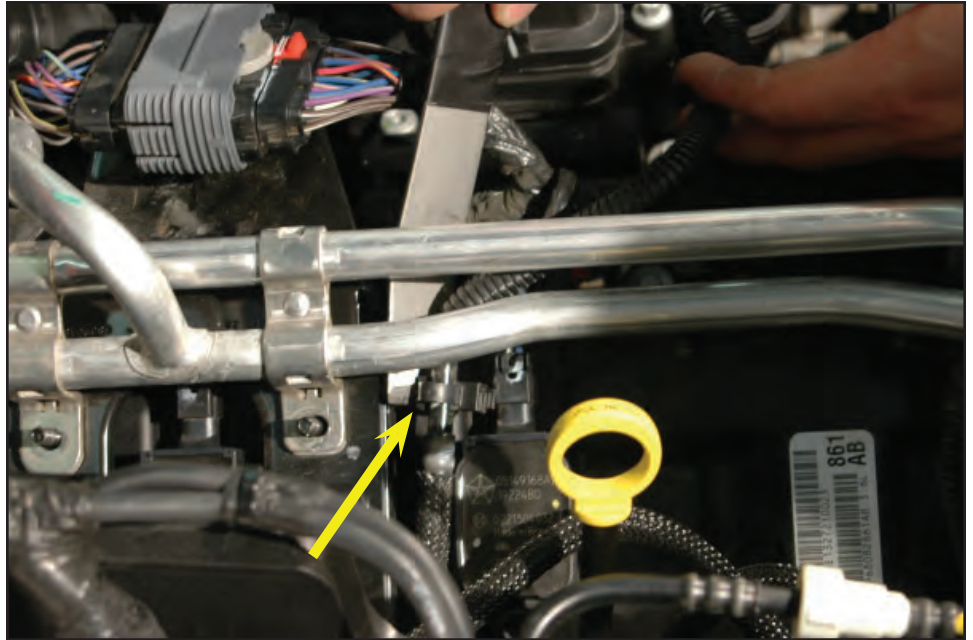

47. Lift up on the heater lines, slide the bracket down toward the exhaust manifold and remove the bracket from the vehicle. This bracket will not be reused, store it in a safe place if you intend to return the vehicle to stock at a later date.

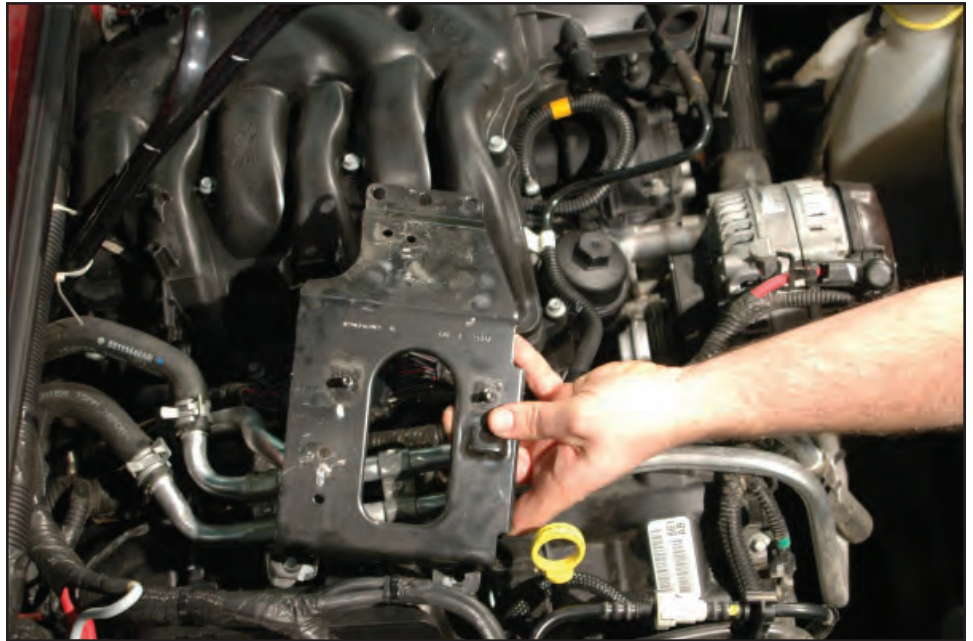

48. Place the provided mounting bracket down toward the exhaust manifold and slide it up and under the heater lines. Reconnect the bracket to the studs near the base of the valve cover and secure with a 10mm socket. **DO NOT reconnect the heater hard-lines to the studs on the new mounting bracket with the OEM nuts at this time.** Reconnect the two tree connectors to the holes on the new bracket. Install the provided 1/2"OD x 1/4"ID x 3/16" spacers over the studs shown with red arrows.

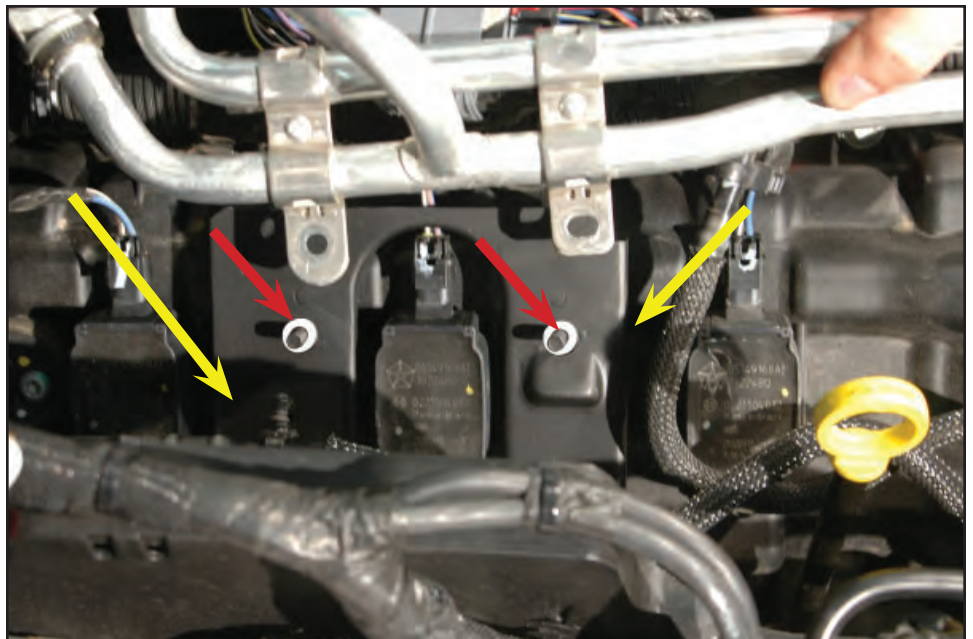

49. Carefully use a tree clip removal tool to disconnect the two tree connectors holding the main wiring harness to the back, right-hand side upper intake manifold.



50. Use an 8mm socket to remove the seven intake manifold mounting fasteners. Three are on the top, and four are at the base of the intake manifold. Pull up and twist the upper mounting bolts counter-clockwise to have the bolts held in the extended position.



51. Lift up on the right hand side of the upper intake manifold then slide the assembly to the right while lifting to remove the assembly from the vehicle.



52. Carefully remove the intake manifold gaskets from the vehicle.



53. Use a shop vacuum to remove any debris on and around the intake manifold.



54. Use isopropyl alcohol or other non-petroleum based solvent to carefully wipe clean the intake manifold ports.



55. Cover the exposed ports with tape to prevent contamination of the engine with debris.



56. Remove the left hand side foam insulation from over the valve cover.



57. Disconnect the EVAP hose by the fuse center by pulling up on the release tab and separating the two components. These are located next to the fuse box.



58. Carefully open the clamp holding the forward piece of the EVAP tube by prying on the center just above the split. This clamp pivots up.



59. Remove the forward section of the EVAP tube from the vehicle.



60. Pull the blue locking clip from the front-left side fuel rail.



61. Disconnect the two clamps holding the fuel line to harness.



62. Rotate the fuel line to expose the white locking clip on the bottom. Carefully remove this locking clip out and pull the fuel line off the fuel rail. Have some shop rags handy to catch any residual fuel in the fuel line. Dispose of contaminated shop towels in an appropriate manner.



63. Pull up on the fuel injector locking clips, and squeeze the release tab to remove the six fuel injector connections (three each side).



64. Carefully disconnect the three left side coil connectors.



65. Carefully pull out the four (two each side) wire loom mounting tree connectors holding the injector/coil wire looms to the valve covers.



66. Tuck the left hand side wire loom out of the way to the left hand side of the engine compartment.

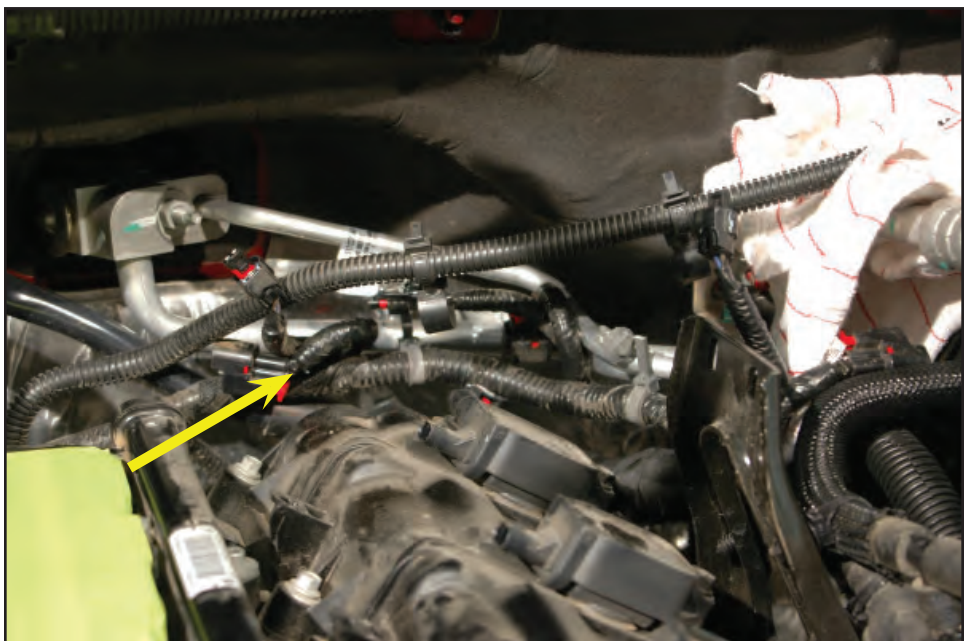

67. Use an 8mm socket to remove the eight lower intake manifold mounting fasteners.



68. Pull the lower intake manifold forward and up. There is one remaining wire loom tree connector that needs to be carefully pried out of the rear of the intake manifold prior to pulling the manifold out of the vehicle. Remove this connector and set the lower intake manifold aside. **There will still be residual fuel in the fuel rails, so cap this line and have rags or shop towels ready to catch any spilled fuel. Dispose of contaminated shop towels in an appropriate manner.**



69. Use a shop vacuum to clean any debris from the intake ports of the heads.



70. Wipe the ports clean using isopropyl alcohol or some other non-petroleum based solvent.



71. Place strips of tape over the intake ports to protect the engine from debris contamination.



72. Use a long ½" drive breaker bar to turn the tensioner clockwise (if facing the alternator from the front of the vehicle). With the help of an assistant, compress the tensioner and remove the accessory drive belt.



73. Disconnect the alternator voltage control connector.



74. Disconnect the alternator positive battery cable using a 13mm socket.



75. Remove the two upper 15mm alternator mounting bolts securing the alternator to the engine and the two lower 13mm bolts holding the alternator to the mounting bracket.

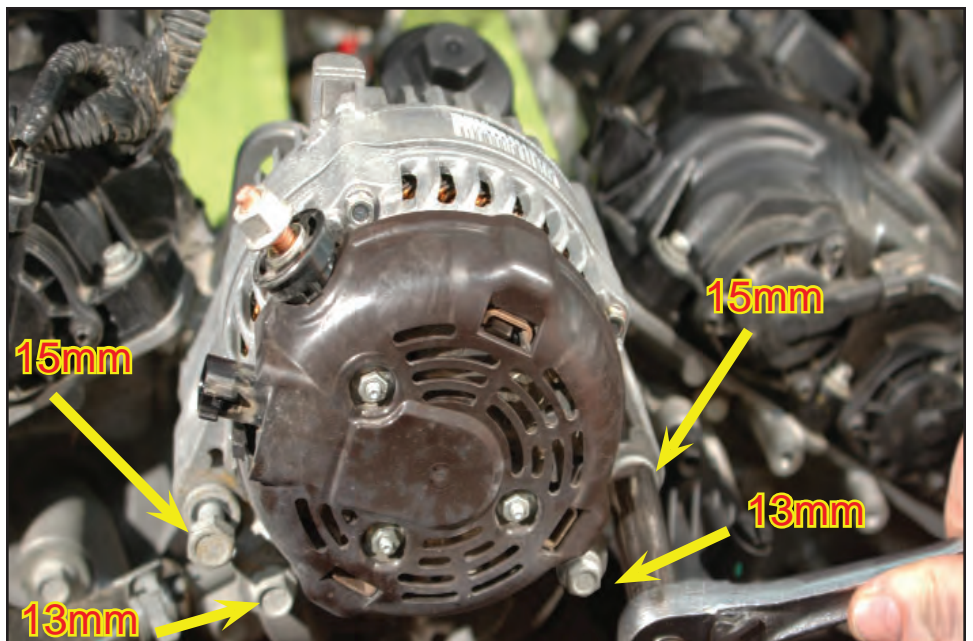

76. Remove alternator from vehicle, set aside for reinstall in a later step.

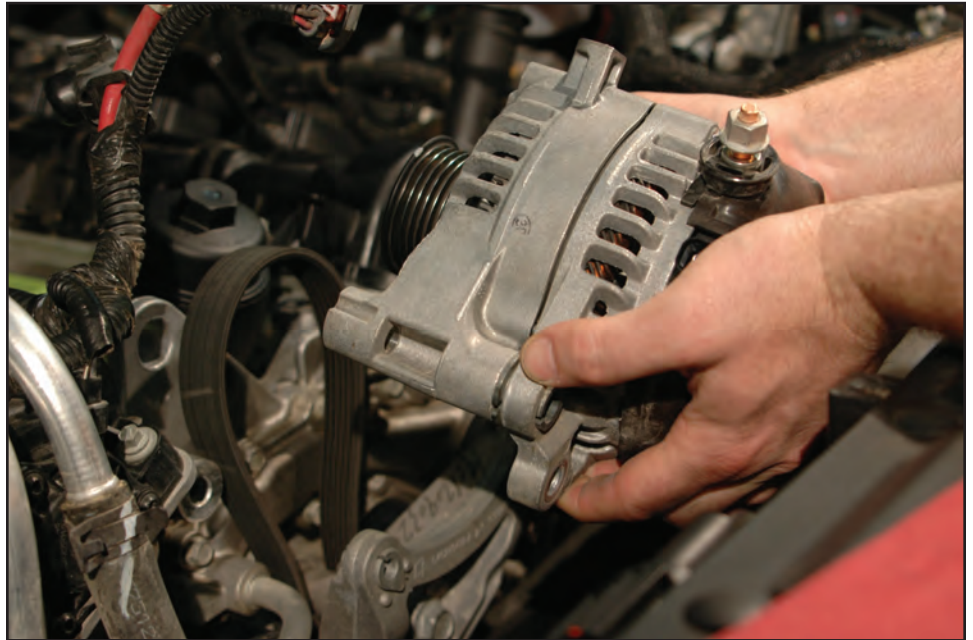

77. Remove the two remaining fasteners holding the alternator mounting bracket to the engine using a 13mm and 16mm socket.

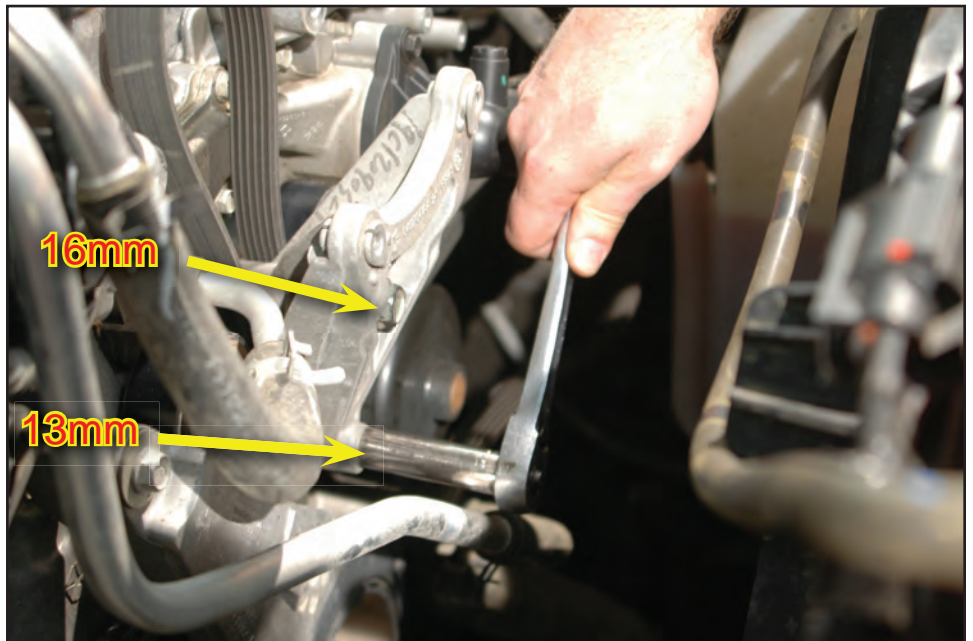

78. Remove the alternator mounting bracket. This bracket will be replaced with a provided bracket. Set aside in case you ever want to return the vehicle to factory condition.



79. Remove the accessory drive belt from the engine. This belt will be replaced with a provided accessory drive belt that will incorporate the supercharger drive pulley into the belt routing.



80. Use a 13mm socket to remove the right idler pulley that is just above the tensioner pulley.



81. Install the provided low profile fastener in the vacated hole adjacent to the remaining idler pulley above and to the left hand side of the tensioner pulley. Note: For clearance reasons this bolt does not have a washer



82. Torque the provided low profile fastener to 40 ft-lbs. Verify your torque wrench settings.



83. Install the provided drive belt following the diagram at the back of this manual. At the top, create the triple-loop configuration shown. Use a zip tie to loosely hold the belt.



NOTE: If you have opted for the smaller pulley refer to the provided Jeep 3.6 Pulley Addendum.

84. This is the new alternator mounting bracket with pre-installed idler pulleys. Install the three mounting fasteners as shown in this picture. The M10 x 150mm in the upper location, the M8 x 100mm at the bottom, and the M8 x 50mm to the right side as illustrated.

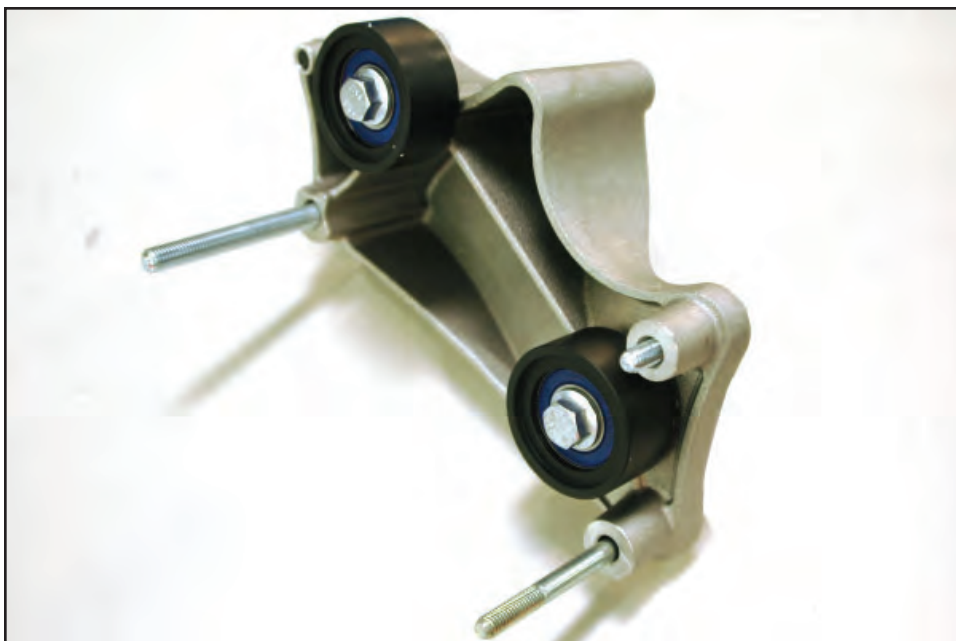

85. Install the new alternator mounting bracket, slipping the loop of the accessory drive belt around the upper idler pulley on the back of the alternator mounting bracket.

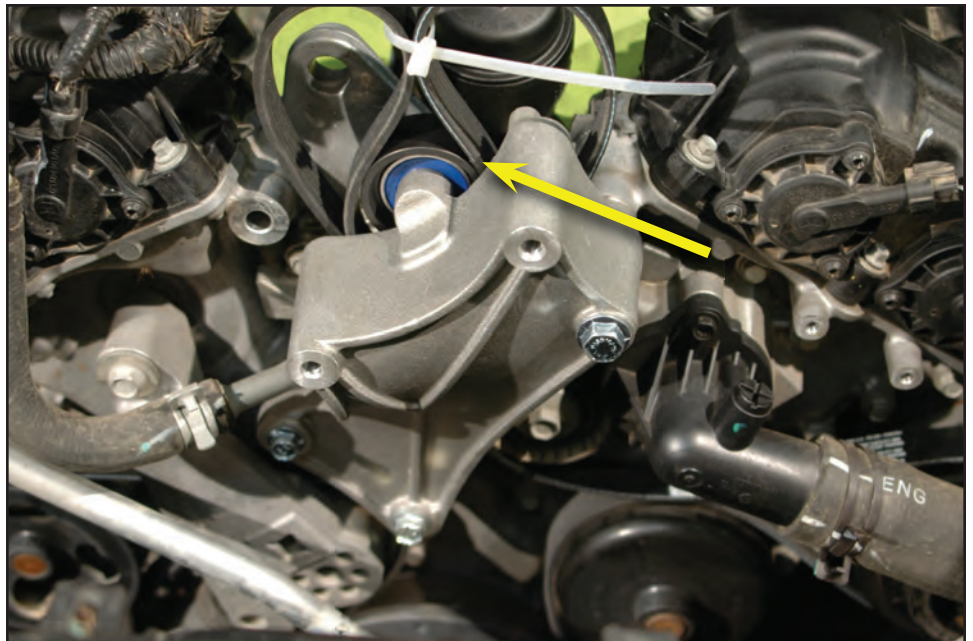

86. Torque the mounting fasteners to 25 ft-lbs for the 12&13mm headed bolts, and 40 ft-lbs for the 15mm headed mounting bolt. Verify your torque wrench settings.

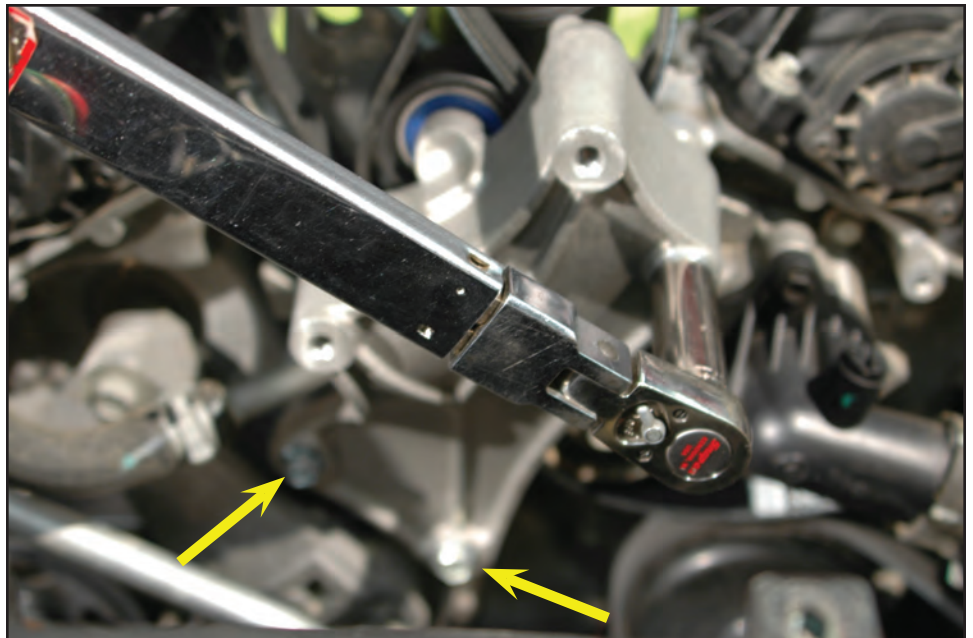

87. Press the offset alternator nut into the upper mounting hole of the alternator mounting bracket as shown.



88. Install the alternator onto the new alternator mounting bracket using the two M8 x 30mm supplied bracket bolts, and a factory M10 x 130mm bolt removed earlier in the right hand side of the alternator. **Remember that right hand and left hand side are referenced from being seated in the driver seat of the vehicle.**



89. Tighten the M8 x 100mm fastener in the left hand side mounting location engaging the previously installed offset alternator nut.



90. Torque the M10 fasteners with a 15mm socket to 40 ft-lbs. Torque the M8 fasteners with a 13mm socket to 25 ft-lbs. Verify your torque wrench settings.

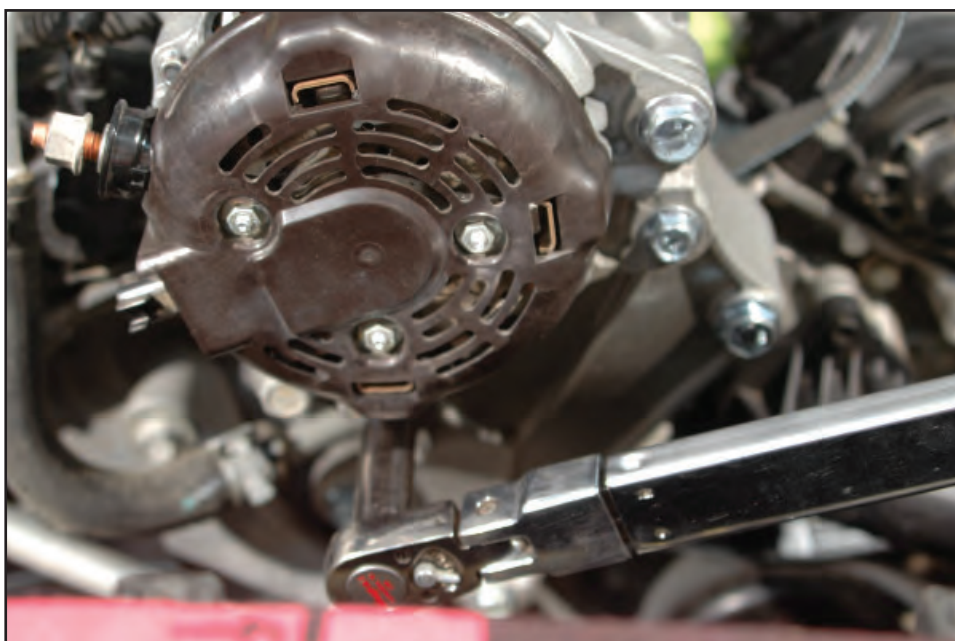

91. Reconnect the alternator voltage cable. Use a 13mm socket to tighten the positive battery cable. Snap the plastic cover over the positive battery cable terminal.



92. Reconnect the alternator control connector.



93. Connect the short leg of the 1.5" x 60" x 3/4" 90° elbow hose that is covered with split loom (not shown in these photo's), on the left hand side supercharger charge air cooler hose barb using a provided worm gear clamp. Connect the short leg of the 2.5" x 18" x 3.4" 90° elbow hose on the right hand side supercharger charge air cooler hose barb and secure using a provided worm gear clamp. Both hoses should point to the left hand side of the installed supercharger.



94. Remove the OEM gaskets from the OEM intake manifold, clean and inspect for damage, if damaged replace with OEM gaskets from your Jeep dealer. Install in the grooves on the bottom of the supercharger intake manifold. Do not allow any debris to fall into the supercharger intake manifold.



95. If you didn't remove the two PCV vacuum tube assemblies earlier and tied them up instead, remove the zip tie holding the vacuum hoses to the cross deck harness. These should be accessible now, remove the two PCV vacuum hoses by pulling the rubber connectors off the PCV barb at the back of each valve cover.



96. At the firewall, pull the four center-most cross vehicle wire loom mounting tabs off of the mounting posts. Use the center most mounting clips to "hold" the harness up using the hood rear seal. Alternately, you can tie the loom to the hood-deck support brackets using provided zip-ties.

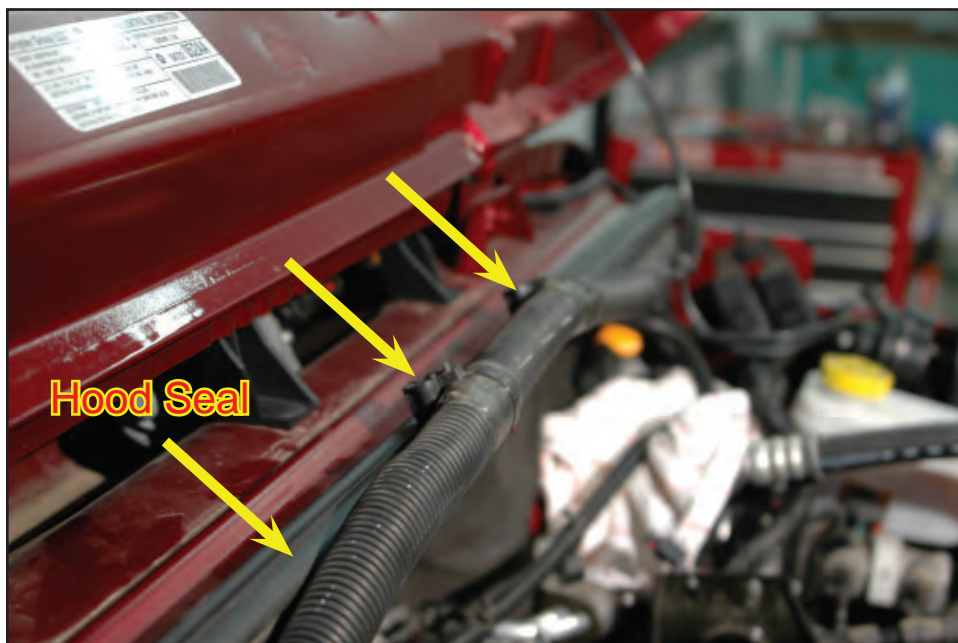

97. Using a grinder or bolt cutter this mounting post at the center of the firewall can be removed to make a significantly easier install, it is not absolutely necessary if you are attempting to retain 100% OEM returnability but is recommended.



98. On the right hand side the main wiring harness runs parallel to the valve cover. At the center connector, first pull the red locking clip out, then slide the gray sleeve over (to the left in this picture) to allow this connection to be separated. Disconnect the plug.

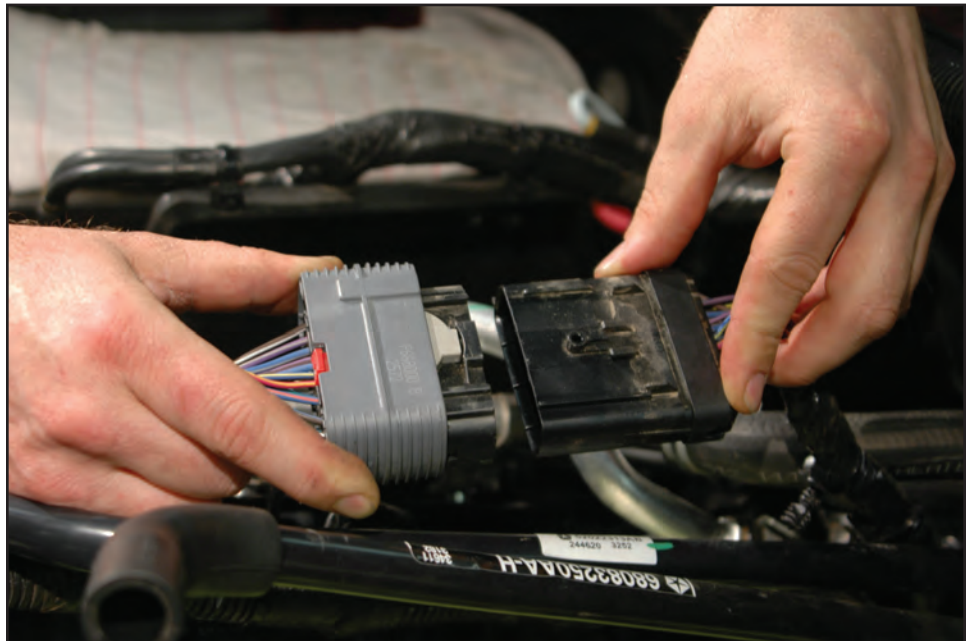

99. Route the rear harness under the existing heater hose connecting to the hard line coming up from the back of the engine compartment. It does not need to be reconnected at this time.

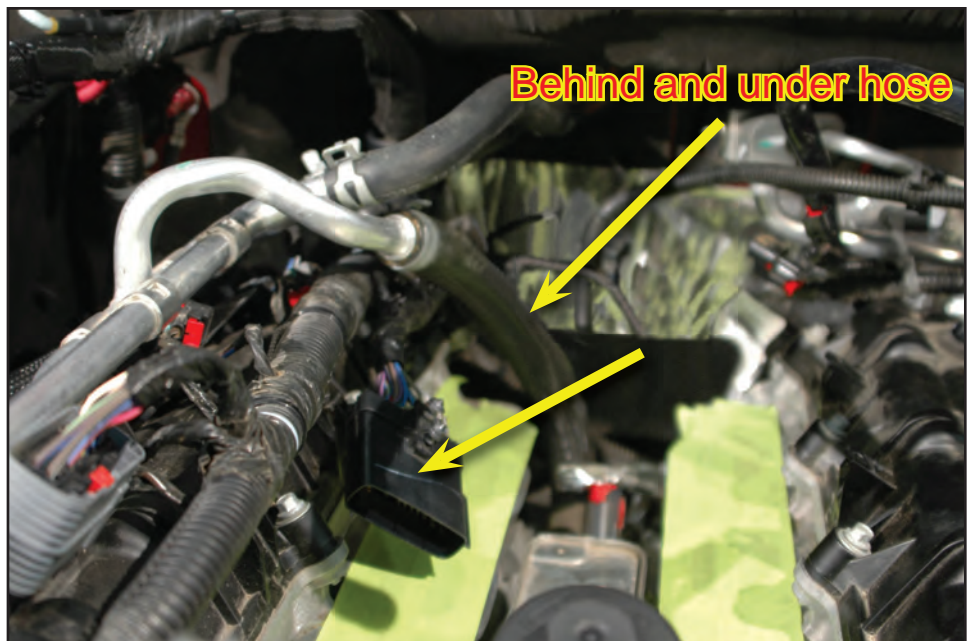

100. A heater hose needs to be removed. There will be some residual coolant in the hose, to protect the ports, place some shop towels down over the intake ports of the heads in the valley cover. The tape should still be covering the ports at this time.



101. Before removing the heater hose, loosen the radiator cap to relieve any pressure still in the system. Disconnect the center most heater hose running from the firewall forward, and angling over toward the right hand side fender to connect to the hard line. There will be some fluid in the hose and barbs, the shop towels should take care of this residual fluid. Dispose of contaminated towels appropriately.



102. Use two provided 4" x 18" x 5/8" 90 ° elbow hoses and the provided 5/8" x 5/8" 90 ° plastic elbow (coupling) to create this replacement heater hose assembly. Cover the long straight leg with the provided split loom as shown. Secure coupling (hose-mender) with provided 5/8" spring clamps. Verify the dimensions using your vehicle hard line heater barbs. This image also displays the orientation, with the top of the picture being the firewall end of the assembly.

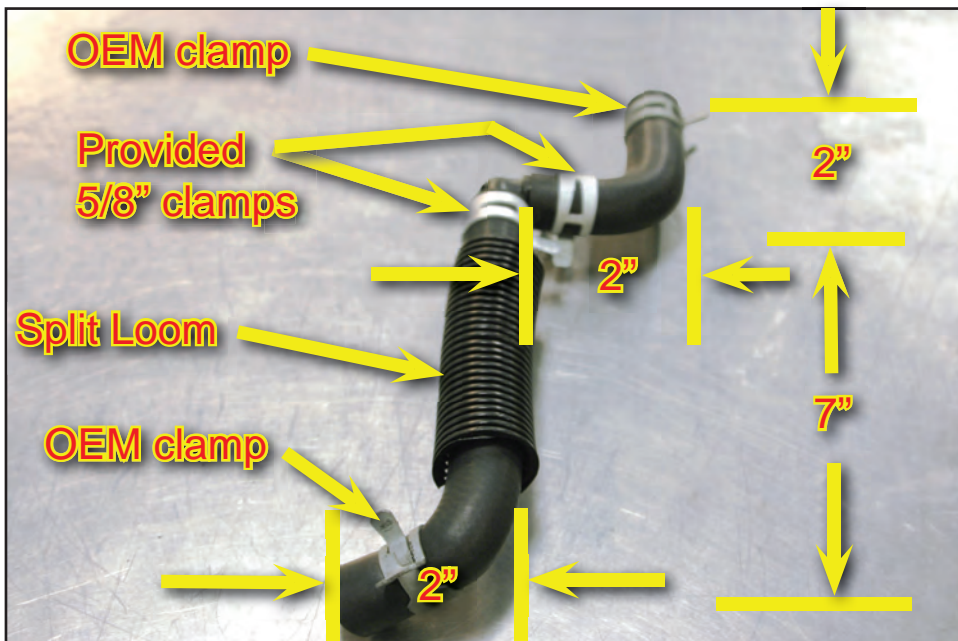

103. Connect the hose assembly to the firewall and hard line locations with the original spring clamps. Replace the radiator cap.



104. Remove the shop towels and the tape from the heads. Be careful to prevent any debris from falling into the ports



105. Use isopropyl alcohol or some other non-petroleum based solvent to wipe the head surfaces clean of any tape residue.



106. Lightly spray some non-petroleum based lubricant (like silicone) or liquid soap on the cylinder heads to allow the supercharger assembly to move freely on the head mating surfaces. With the help of an assistant place the supercharger assembly in position on the heads. The front end of the supercharger will need to go down first, followed by the rear. Allow the supercharger assembly rear to drop into position. While dropping the front down, pull the left hand side upper loop of the drive belt out to engage the supercharger drive pulley.



107. Use a telescoping magnet tip to set the supercharger mounting bolts in position. The four long bolts go in the front and rear mounting holes, and the short bolts fill the center mounting locations.

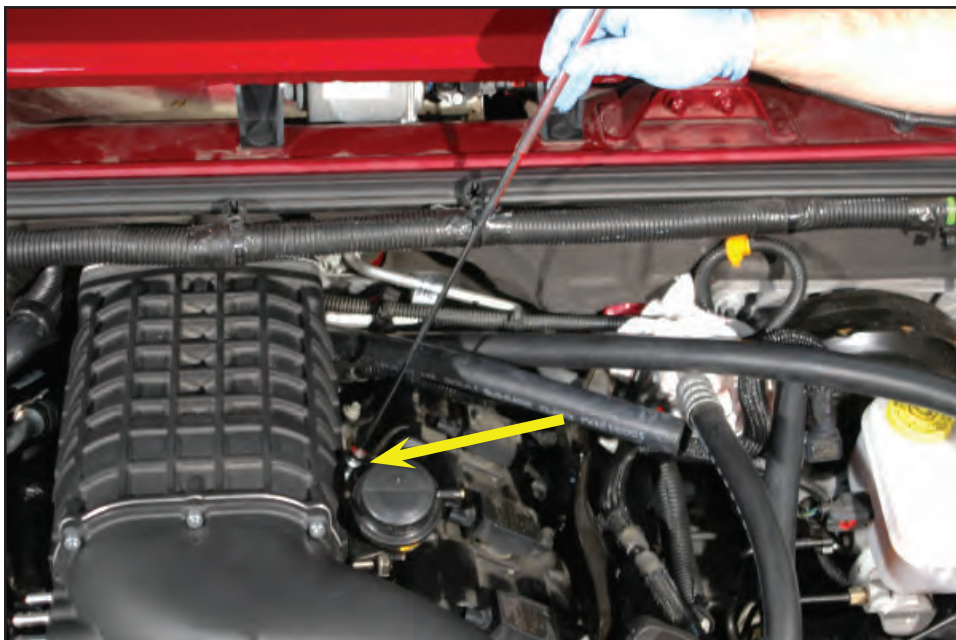

108. Torque all mounting bolts to 106 in-lbs. Use the multi-step tightening sequence shown in the next image.



109. Use this image to sequence the torquing of your mounting bolts. Do NOT torque each bolt down to full specs in a single step. Rather, gradually bring each bolt up to spec rotating in this pattern.

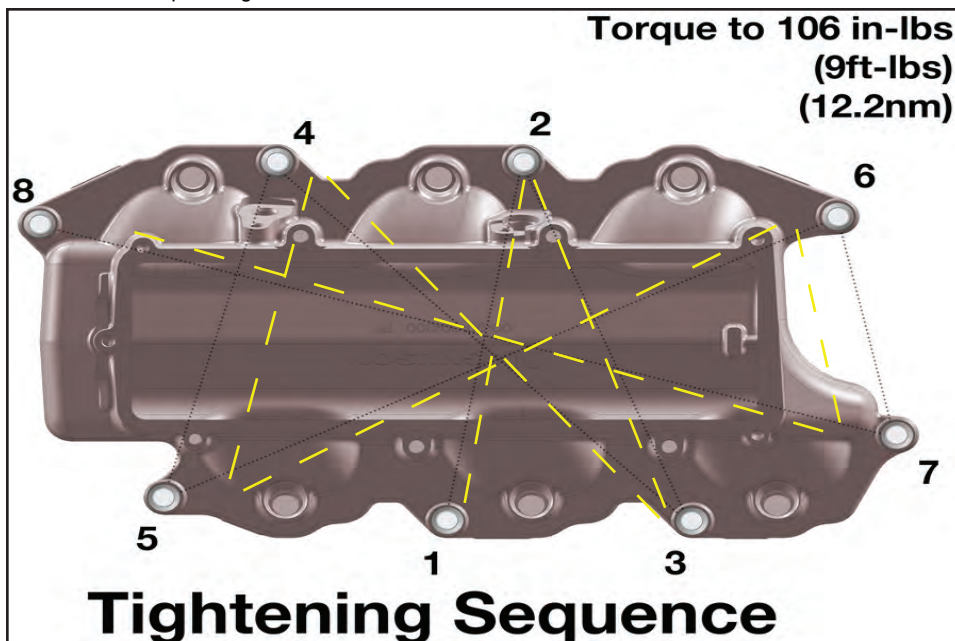

110. Connect the IAT extension harness to the IAT sensor on the left hand side of the supercharger, below the fuel rails.



111. Connect the free end of the IAT extension harness to the existing IAT plug near the throttle body flange of the supercharger.



112. Connect the provided MAP sensor extension onto the MAP sensor connector behind the supercharger, just below the charge air cooler hose connections on the intake manifold.

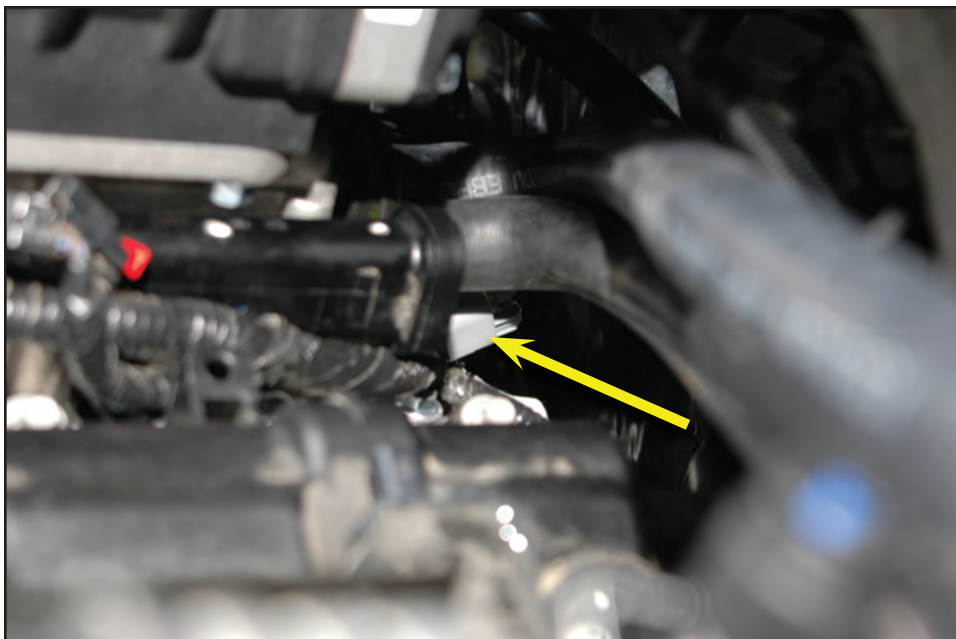

113. Connect the free end of the MAP sensor wire extension harness to the existing MAP sensor plug. **NOTE: Each side of the MAP sensor connection has an offset, the offsets are on the opposite sides from each other! The locking clip will only engage the tab if you align the offsets correctly. You can force the connection with the offsets being on the same side, but in the process you can damage the connectors. ENSURE THE OFFSET OF THE MAP SENSORS ARE ON OPPOSITE SIDES AS SHOWN IN THIS IMAGE.**

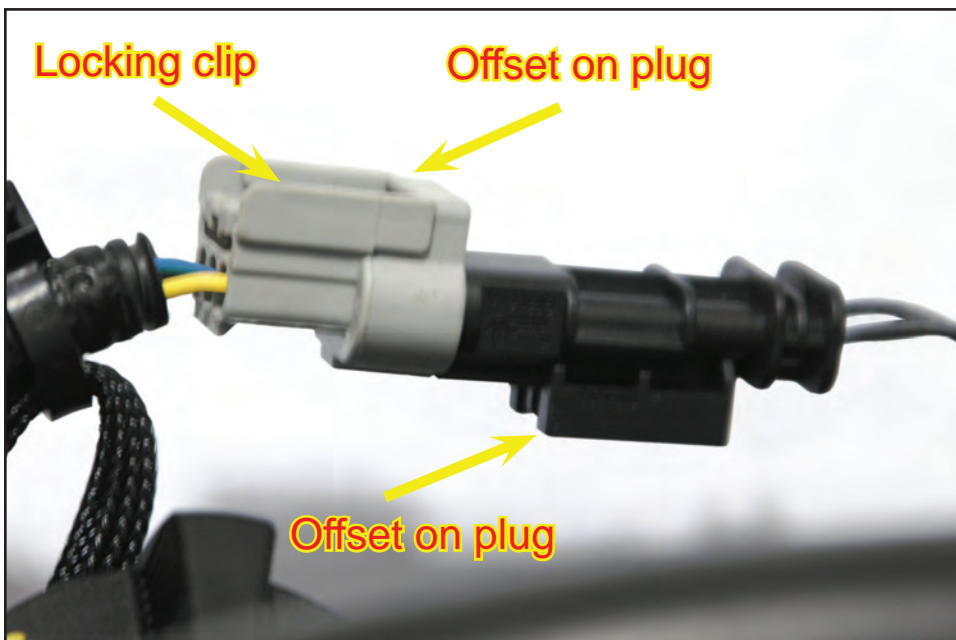

114. Reconnect the six fuel injector plugs (three each side), and the six coil plug connectors (three each side), and press the harness mounting tree clamps back into the four mounting bosses (two each side). If the mounting tree clamps were damaged in dis-assembly, use provided zip ties to anchor in position.

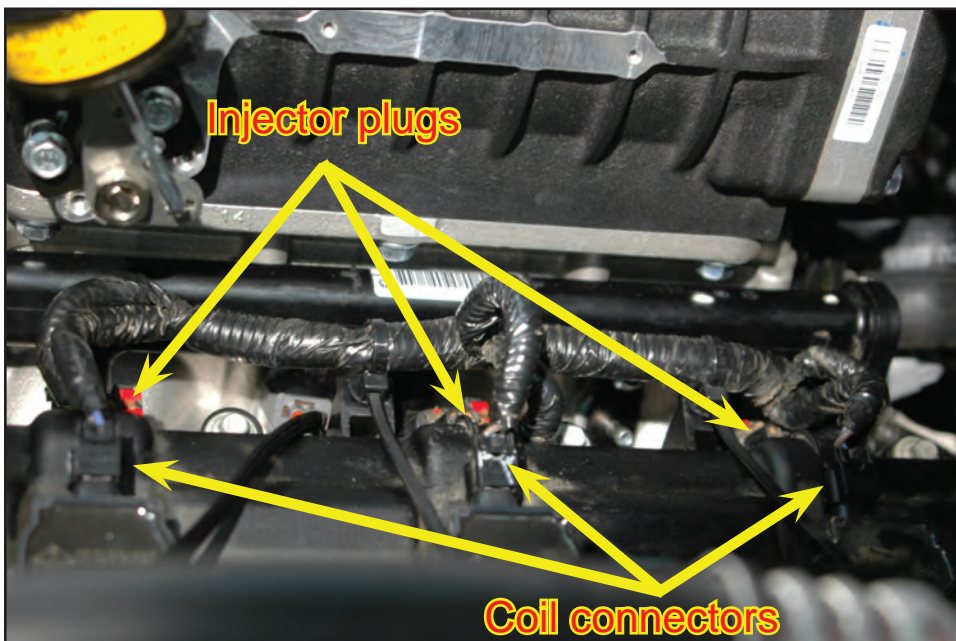

115. Snip the zip tie holding the belt in shape and Use a ½” drive breaker bar to compress the accessory drive belt tensioner and slip the belt over the large smooth water pump pulley. Use the belt routing diagram at the back of this instruction manual as a reference.



116. Connect the fuel line locking clips on the fuel line.



117. Snap the fuel line back onto the fuel rail at the front barb of the left hand side fuel rail. Press the locking clips back into secure position. Pull on the fuel line. It should not be able to be removed without releasing the locking clips.



118. Route the removed left hand side PCV tube assembly under the supercharger inlet with the right angle hose connector returning to the OEM hose barb at the rear of the left hand side valve cover. Connect the ends of the right angle hose connector to the tube and PCV barb at the rear right hand side of the valve cover using provided worm gear clamps.



119. Use two provided hose couplings/menders to the ends of the provided 5/8" fuel vapor hose. Remove the OEM PCV hose ends from the removed right hand side PCV tube assembly. Place one end on each hose coupling. Connect the larger connector end to the PCV barb at the rear of the right hand side valve cover.

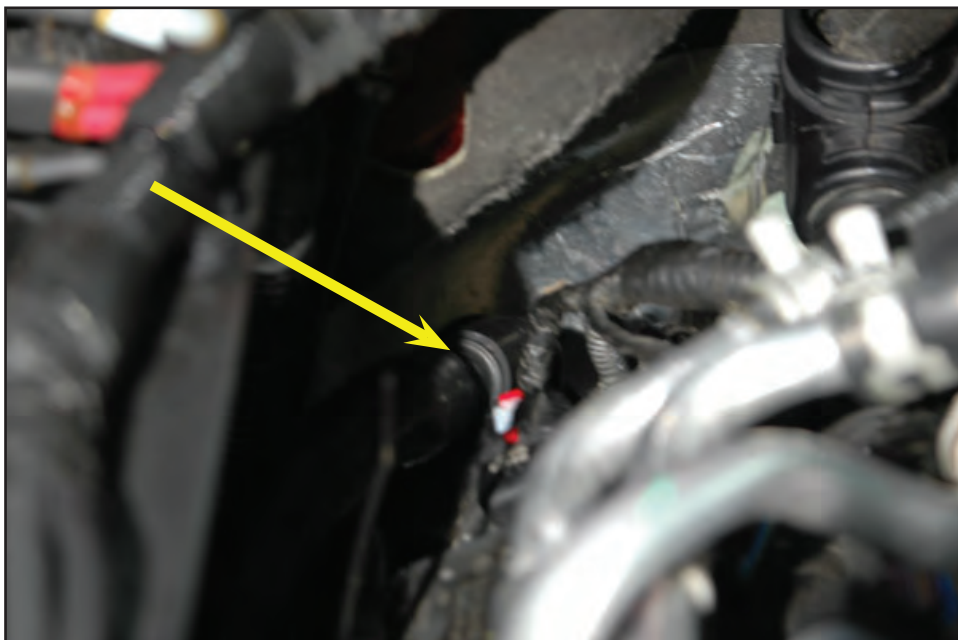

120. Connect the other 45° connector end to the right hand side PCV hose barb on the supercharger inlet shown with a yellow arrow. Tighten the heater hardlines at the two stud locations. Install the provided swivel spacer, and two 1/2" x 15" cable ties in the location shown with a red arrow.



121. On the right hand side, reconnect the main wiring harness connectors. Slide the gray locking collar back in position and press the red locking tab into closed position.

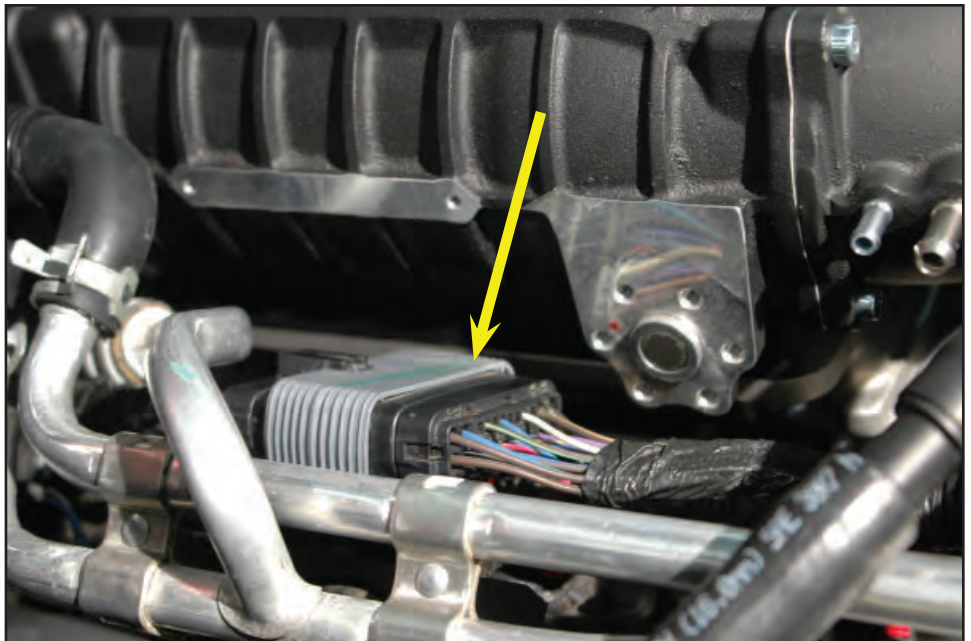

122. Inspect the O-ring installed in the throttle body flange for damage, if damaged call Magnuson for a replacement. Install the OEM throttle body on the new supercharger inlet using the four provided bolts. Torque the bolts to 106 in-lbs. Verify your torque wrench settings.

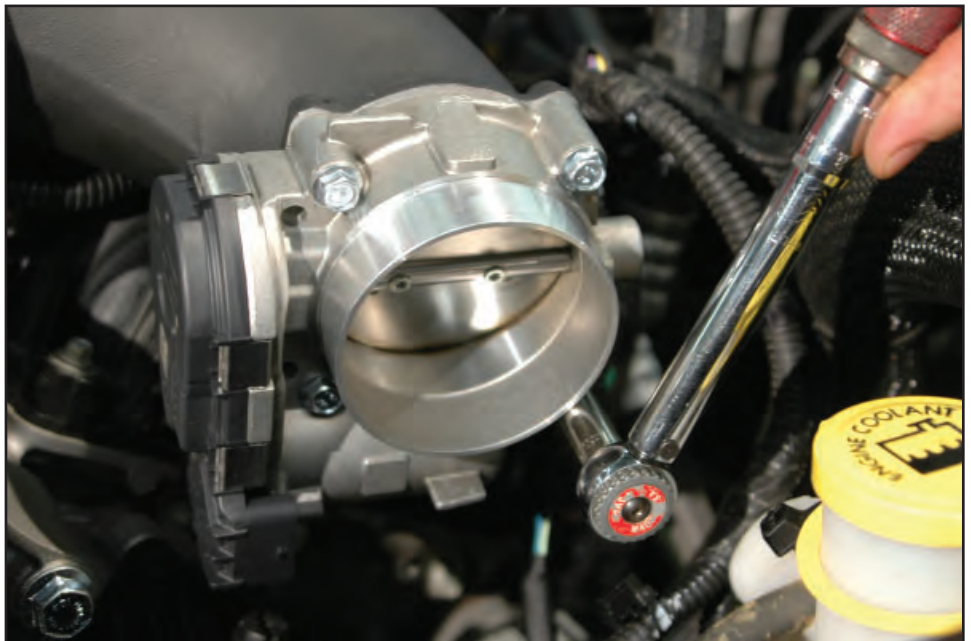

123. Reconnect the throttle body control harness to the throttle body and press the harness mounting clip back on the throttle body mounting tab/boss.

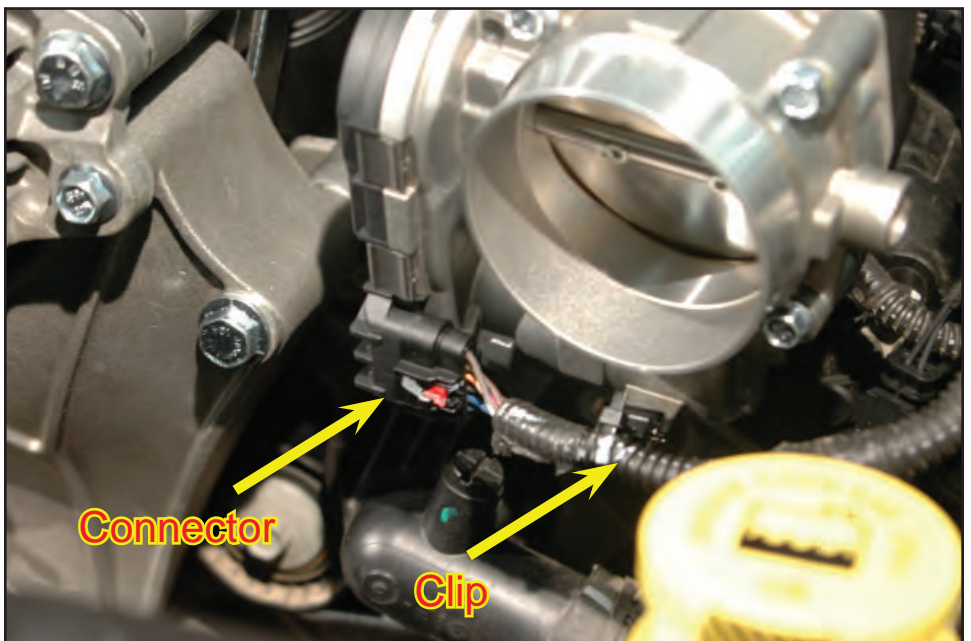

124. Use a 10mm socket to mount the provided intercooler reservoir to the left side rear intake manifold mounting bracket using the provided nuts and bolts.

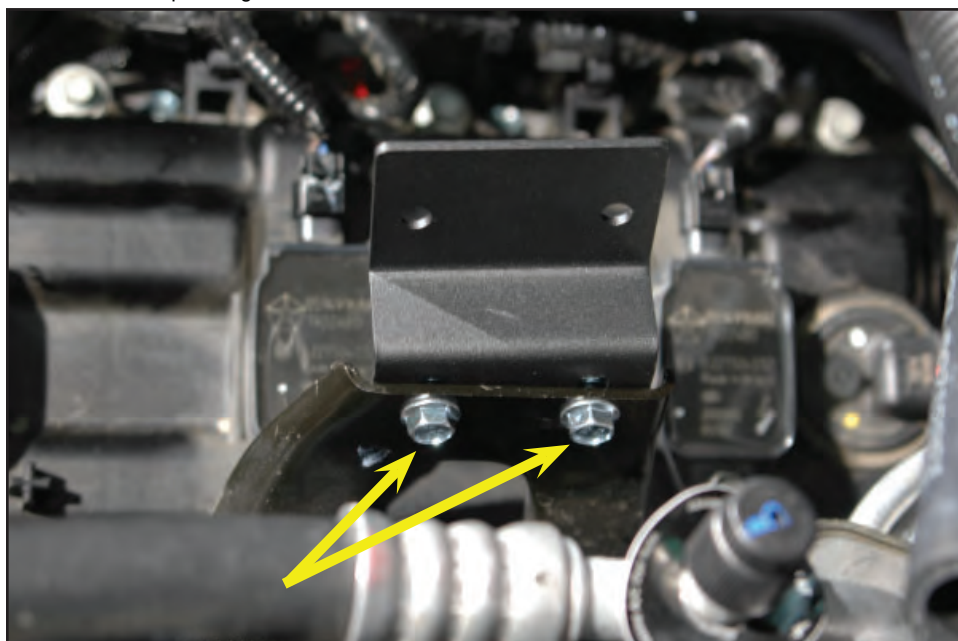

125. Use a 10mm socket and provided fasteners to mount the reservoir to the two mounting holes left on the reservoir mounting bracket just installed. Torque all four fasteners to 106 in-lbs.



126. Cut to fit and connect the right hand side charge air cooler hose (2.5" x 18" x 3/4" 90° angle hose) straight end to the upper hose barb on the intercooler reservoir. **Caution: only use the provided worm gear clamps on the reservoir bottle.**

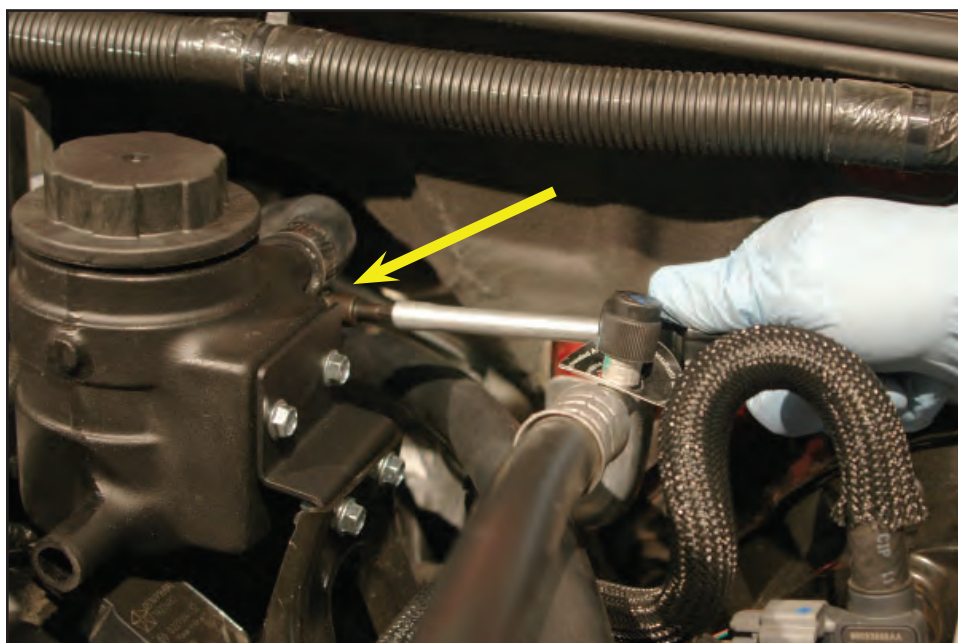

127. Use a screwdriver or plastic prybar to carefully remove the six push pin rivets holding the fascia-grille to the upper radiator support.



128. Disconnect the turn signal connectors on the right and left hand side of the grille-fascia by pulling out the red locking tabs to release the locking clip and pull free.

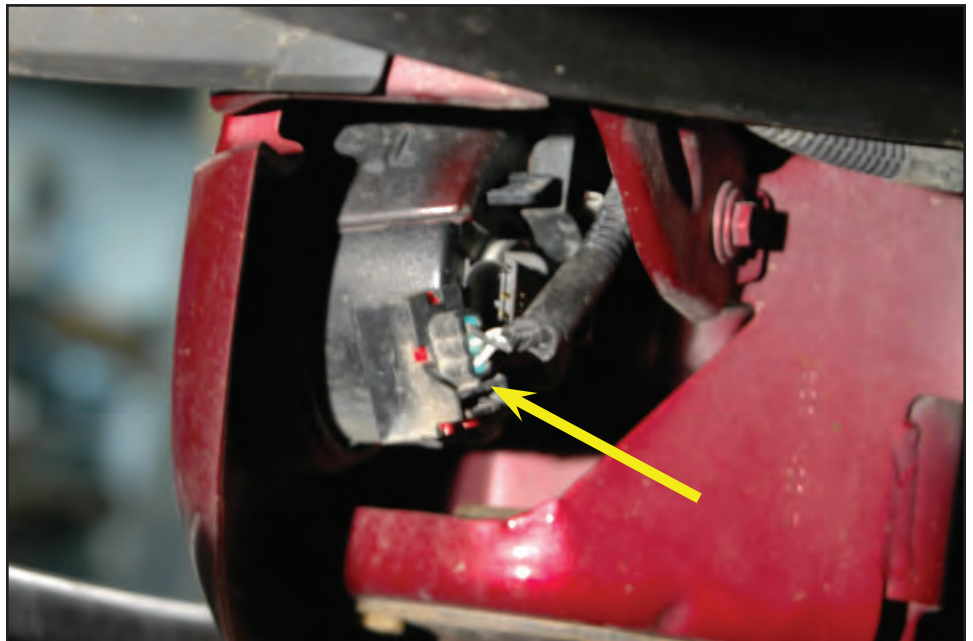

129. Remove the grille-fascia from the vehicle and set aside where it will not be damaged.



130. Cut two strips of the provided adhesive-back rubber to fit the mounting brackets on the bottom of the low temperature radiator (LTR).



131. Press the LTR mounting brackets on the lower cross frame rail, and roughly align the holes with the existing holes in the upper cross frame brace. Slide the provided double nut plate up and into the channel of the upper cross frame brace, and align the nuts with the two existing holes located behind the wiring harness.

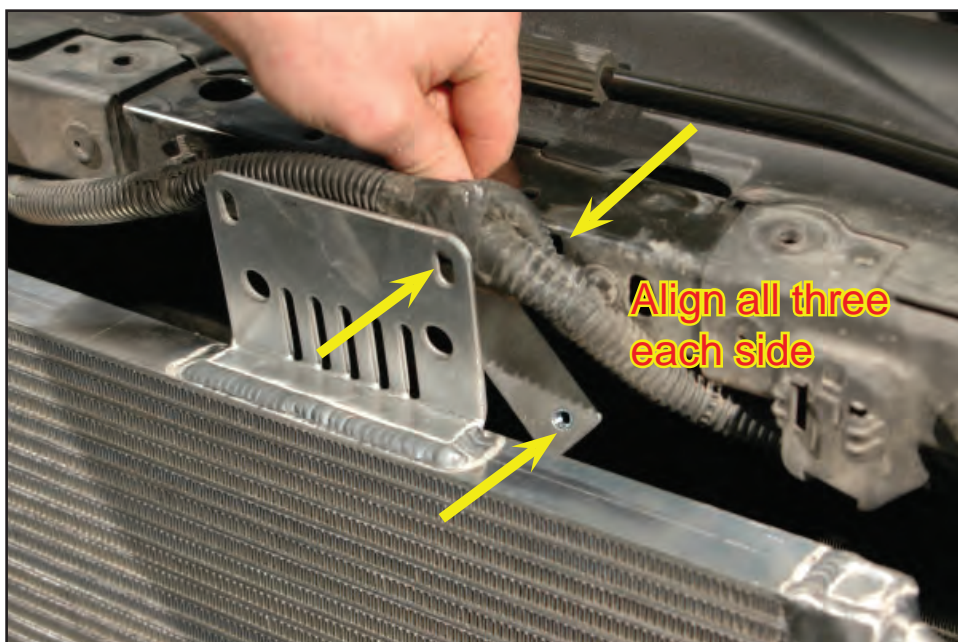

132. Do some final adjusting as necessary and mount the upper LTR mounting bracket to the upper cross frame brace, engaging the two nuts of the double nut plate with the provided bolts. Secure using a 10mm socket.

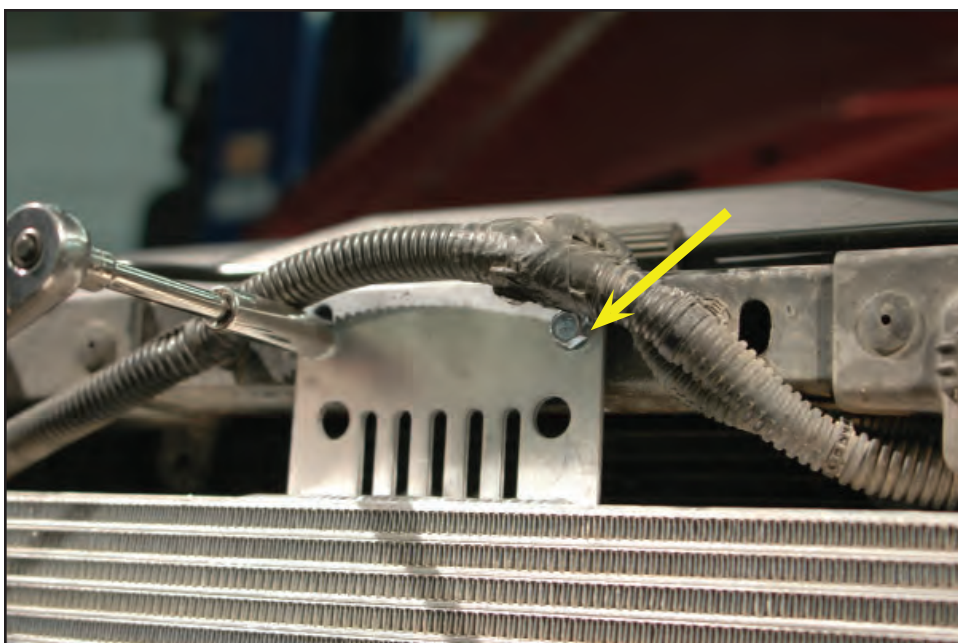

133. Cover the left hand side charge air cooler hose (1.5" x 60" x 3/4" 90° elbow hose) with split loom running forward where it will encounter potential chaffing. Secure in position with black tape or zip-ties. Route the covered hose below the reservoir bottle, forward past the computer out and through the fascia frame to the left hand side of the radiator.

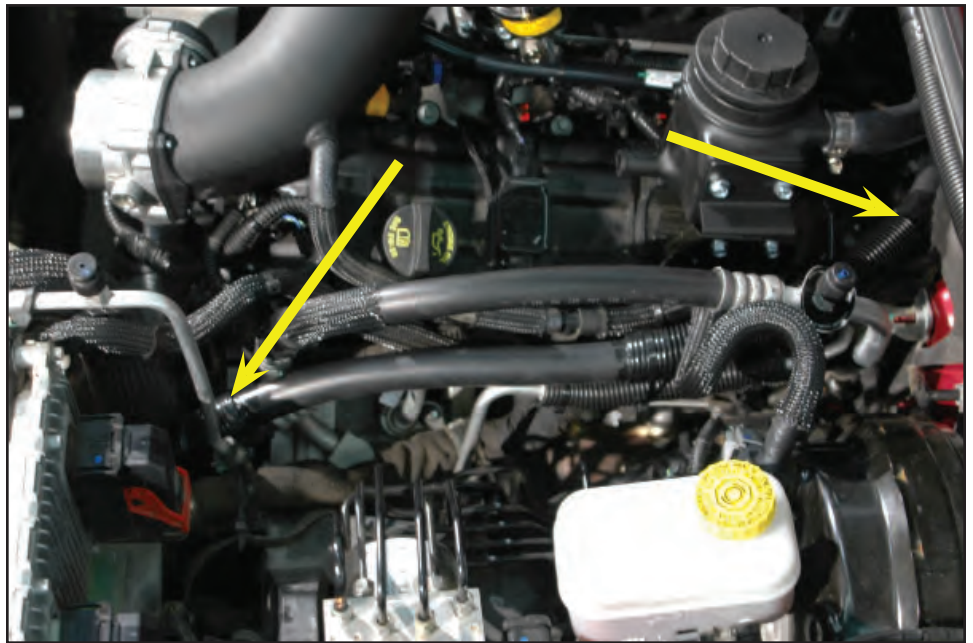

134. Cut the hose as necessary to fit and connect to the upper LTR hose barb using a provided spring clamp.

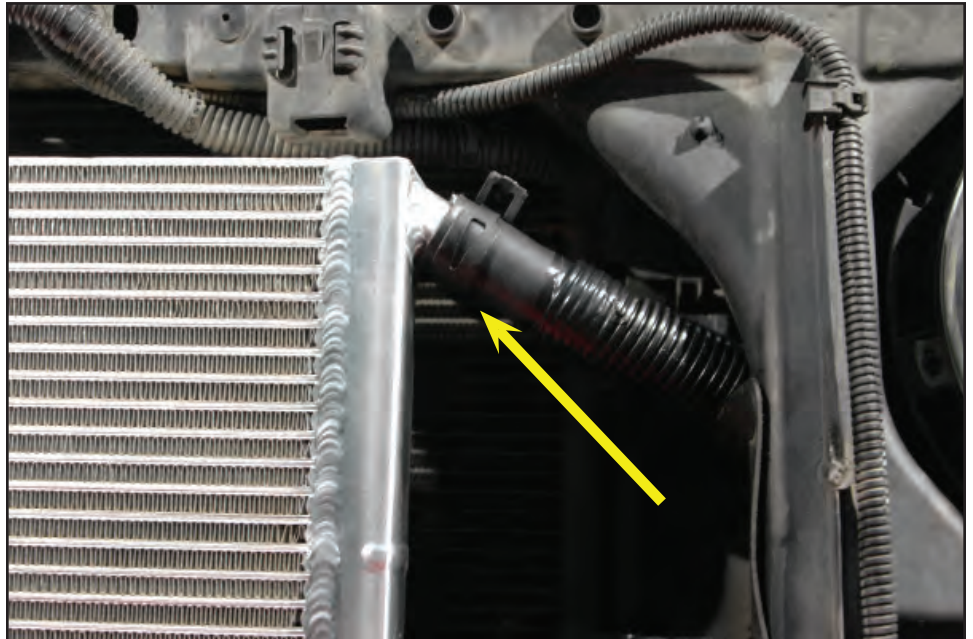

135. Cut four strips of the adhesive backed rubber to two inches in length. Apply these strips to the inside curves of the intercooler pump mounting bracket as shown. **NOTE: Pay attention to the size of the curves, they are intended to match up.**



136. Remove the four push pin rivets into the bumper and two push pin rivets on the back side into the cross frame to release the splash shield from the front/bottom of the vehicle.

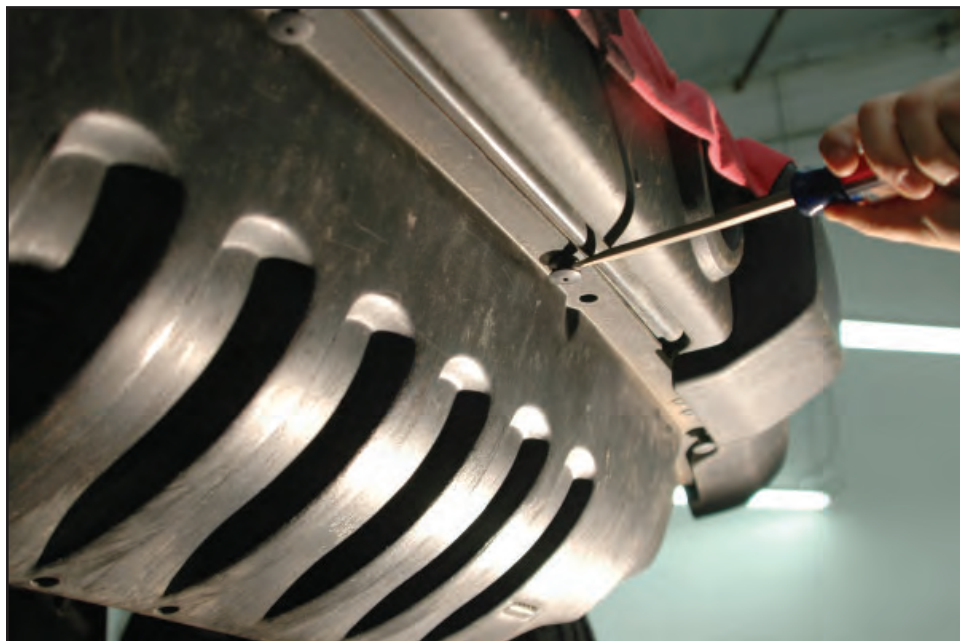

137. Loosely assemble the bracket matching the large and small lobes with the spacers between. Mount the small lobe of the bracket over the lower cross frame tube, spaced about an inch and a half toward the center from the hole on the left hand side to the beginning of the bracket. Slide the intercooler pump into the large lobe (with the rubber strips), rotate the bracket up and forward so that the pump discharge barb is pointing directly under the torsion bar and parallel with the ground. The discharge barb should be a couple inches toward the center from aligning with the lower LTR hose barb. Tighten the mounting bolts when this has been achieved.

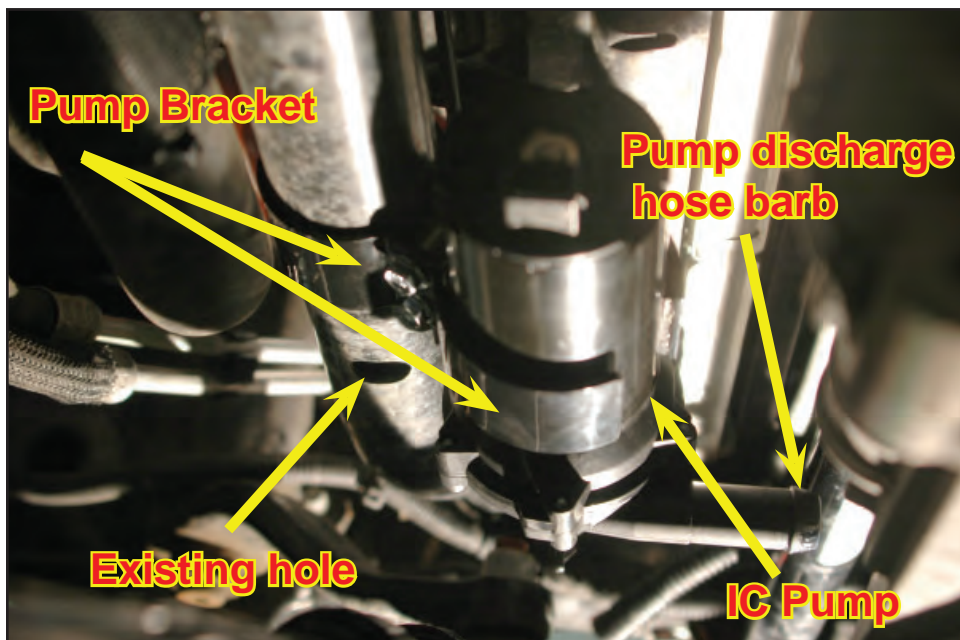

138. Cut the short leg of the 4" x 40" x 3/4" 90° elbow hose to 2.5" as measured on the inside of the curve, and connect to the intercooler pump inlet hose barb using a provided spring clamp. Route the free end up into the engine compartment toward the Reservoir.



139. Connect the short leg of the 4" x 18" x 3/4" 90° elbow hose to the discharge barb of the intercooler pump using a provided spring clamp. Angle the remaining hose toward the left hand side a bit to point directly at the lower LTR hose barb. This hose will be running below the sway bar.

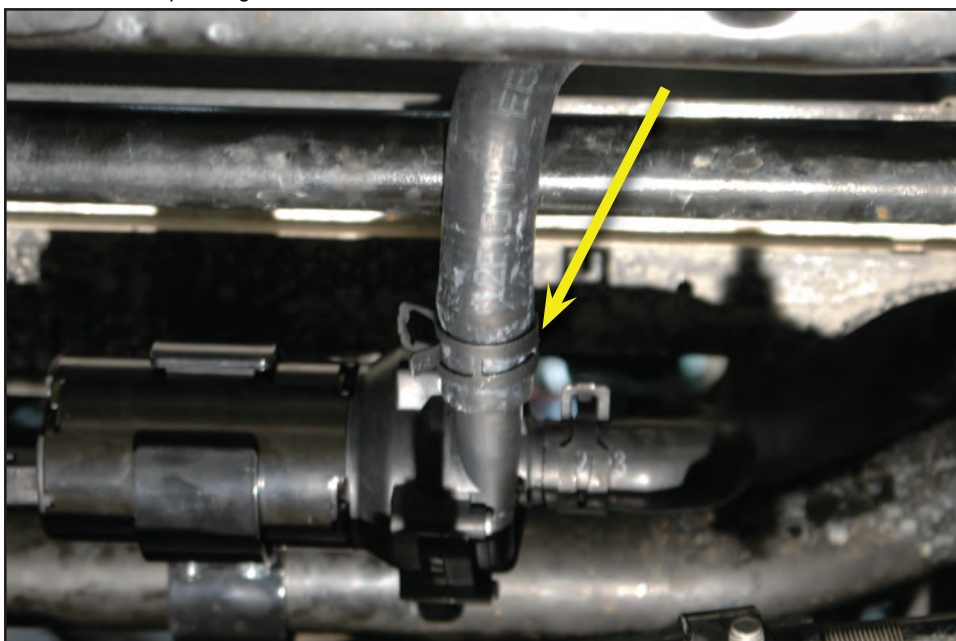

140. Cut the remaining section of the 4" x 18" x 3/4" 90° elbow hose to fit and connect to the lower hose barb on the LTR using a provided spring clamp.

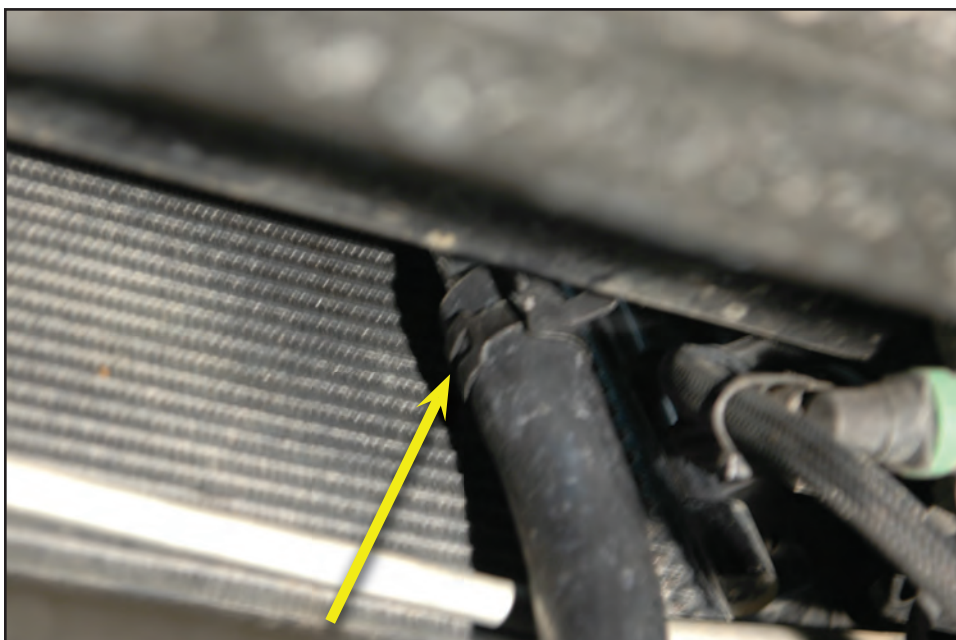

141. Cut the long leg of the 4" x 40" x 3/4" 90° elbow hose to fit and connect to the forward hose barb on the reservoir using a worm gear clamp. It's important to utilize only worm gear clamps on the reservoir. For clarification see the plumbing diagram at the back of this instruction manual.



142. Install the provided fuse in the fuse holder of the intercooler wiring harness and replace the cover.



143. On the inside surface of the battery tray toward the rear there are two holes. Using the provided hardware, attach both the fuse center and the relay to the front hole as shown in this picture.

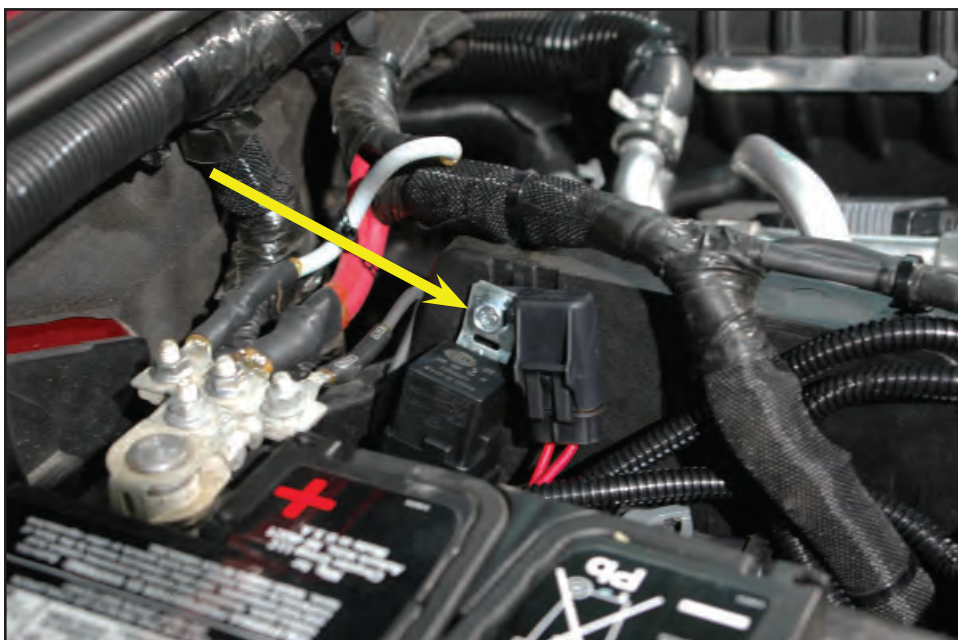

144. Route the split loom covered power connector with the yellow wire incorporated forward. Utilize the vacated clamp of the EVAP center as a mounting point and secure the harness in position by pressing the hinge clamp down over the split loom.

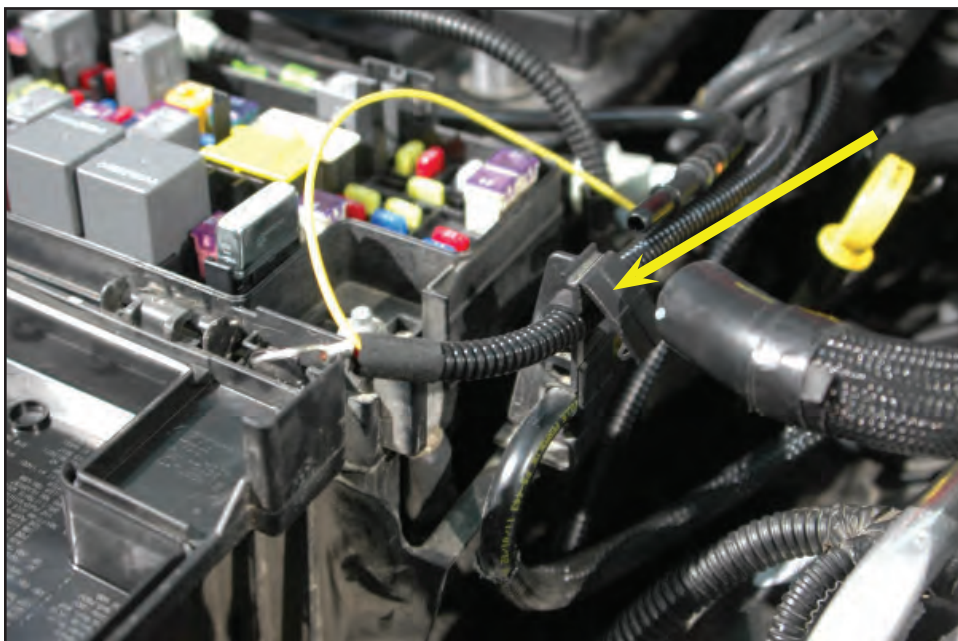

145. Route the black ground wire back to the firewall. Remove the nut on the existing grounding stud and replace incorporating the intercooler harness ground wire.

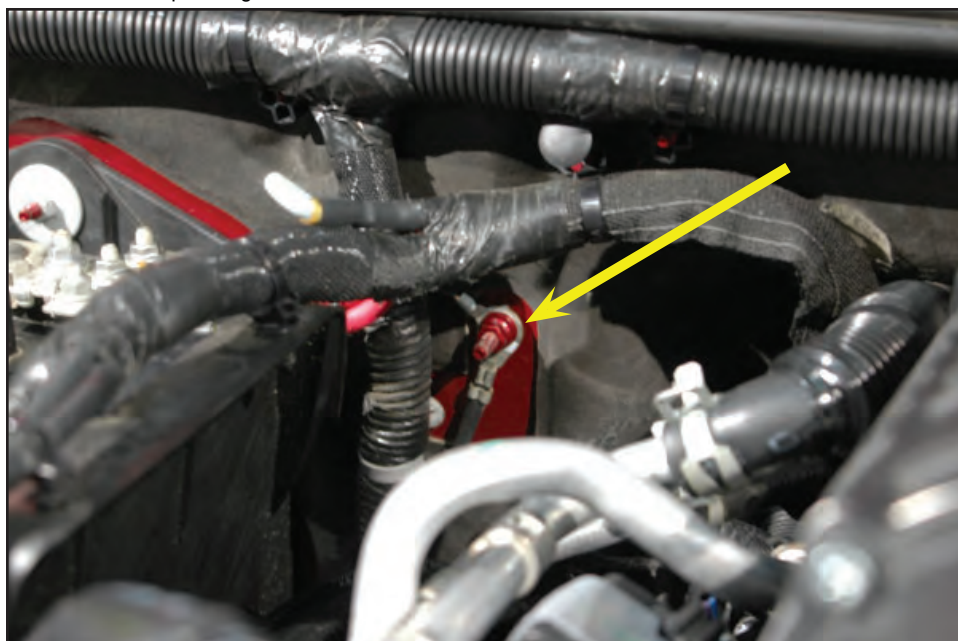

146. Remove the fuse box cover. Use a 1/4" drill bit to drill a small hole in the back wall of the fuse center power lead. Center the hole between the existing fuses beyond as shown.

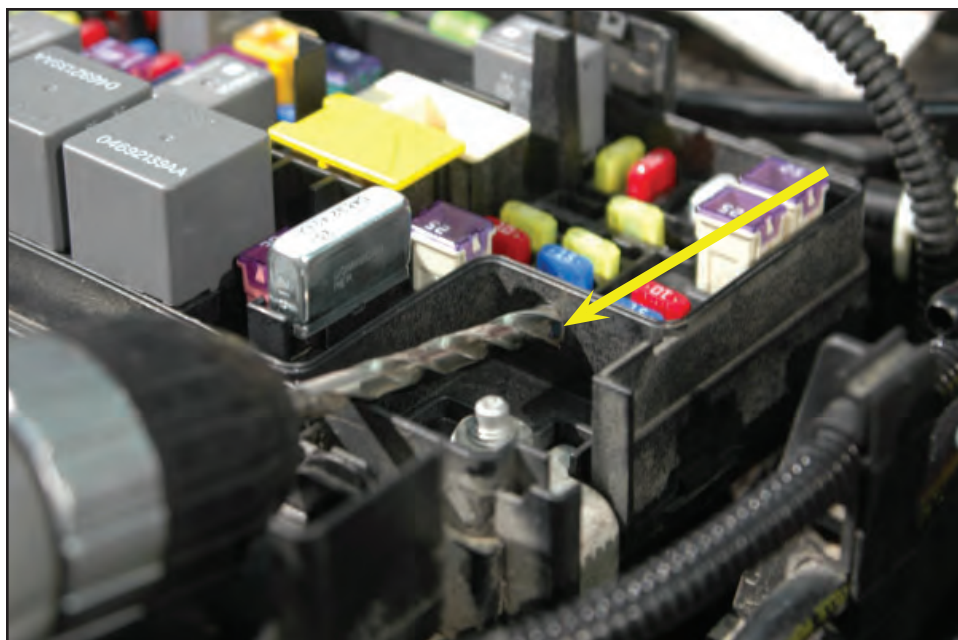

147. Use a 13mm wrench to remove the nut from the hot terminal of the fuse center and replace incorporating the ring terminal on the red wire from the intercooler pump wiring harness.

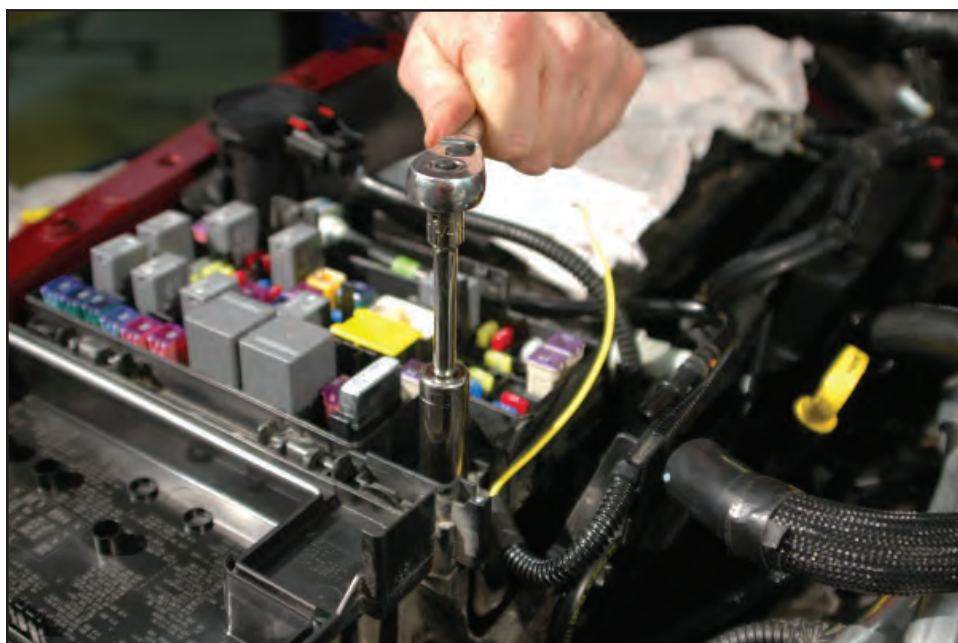

148. Slide the provided grommet over the fuse tap connector onto the yellow wire back down toward the split loom. Route the yellow “trigger” wire through the hole you just drilled and seat the grommet in the opening to seal the box. A dab of silicone will help to maintain a waterproof enclosure.

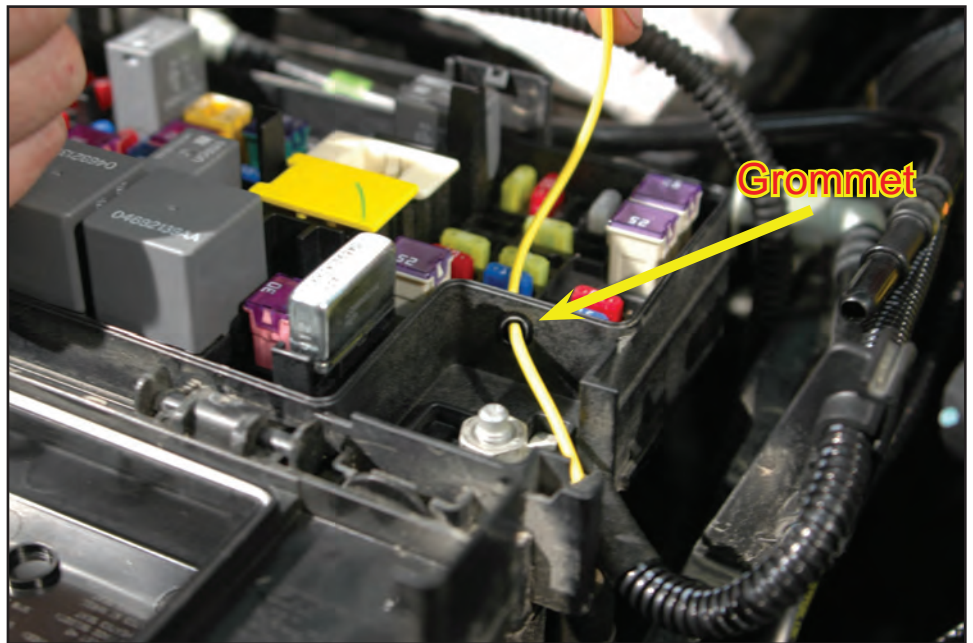

149. Install the provided fuse tap at the end of the yellow wire on one leg of the M37 fuse (fuel pump relay removed earlier).

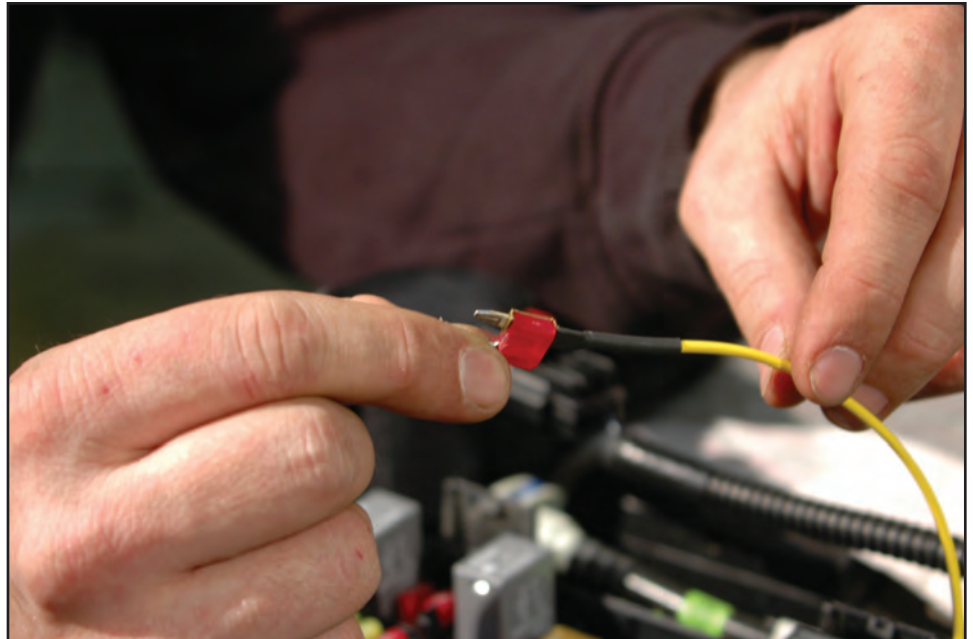

150. Reinstall the fuse in the fuse center M37 slot incorporating the fuse tap.

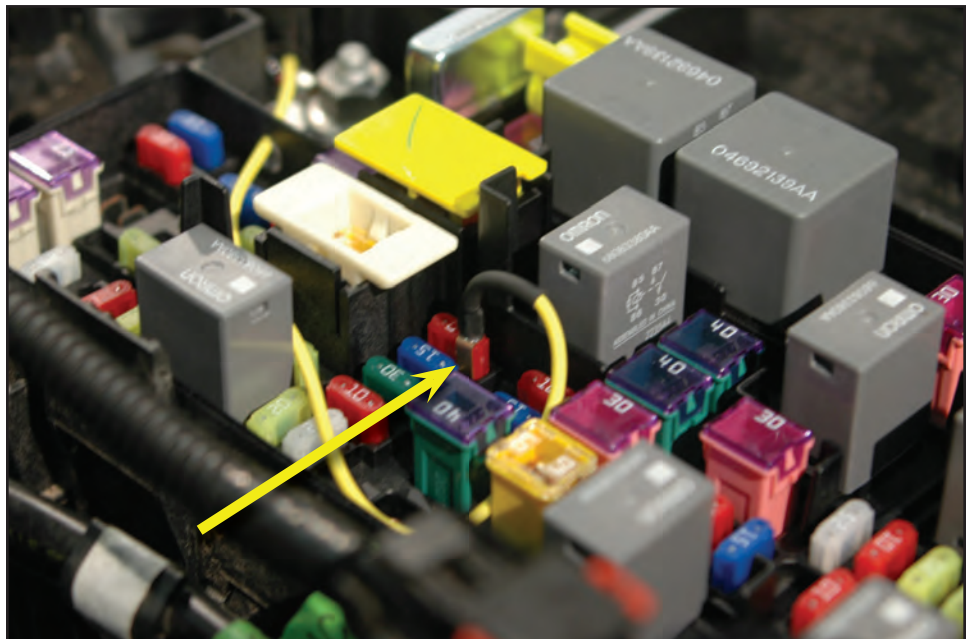

151. Route the remaining intercooler pump connector harness down and forward, over to the intercooler pump and connect to the terminal. Secure the wire with provided zip-tie connectors.



152. Connect the provided EVAP tube connection to the vacated barb near the inside end of the fuse center.

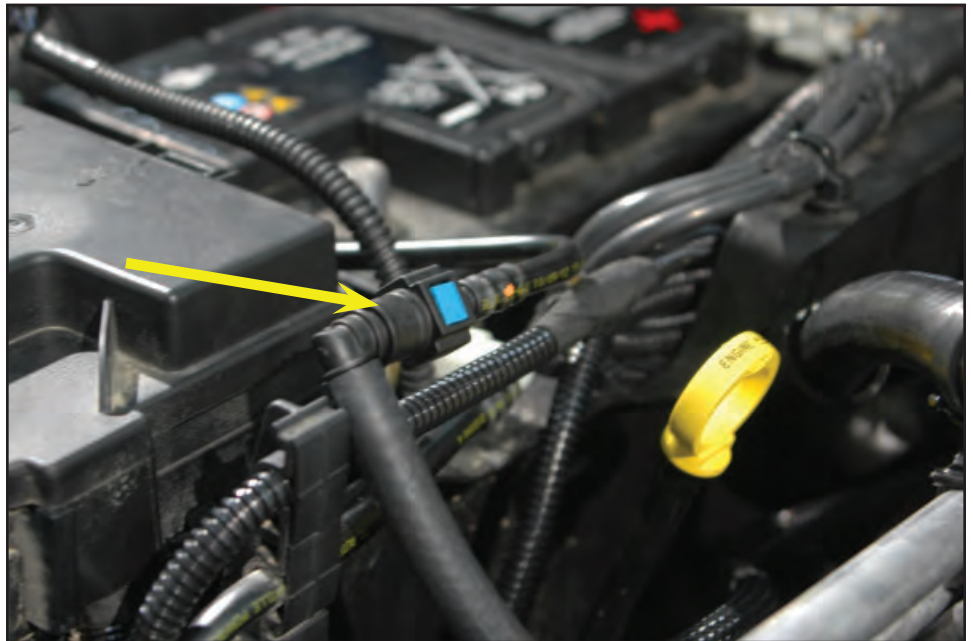

153. Connect the free end of the hose to the center barb on the supercharger on the right hand side of the inlet.

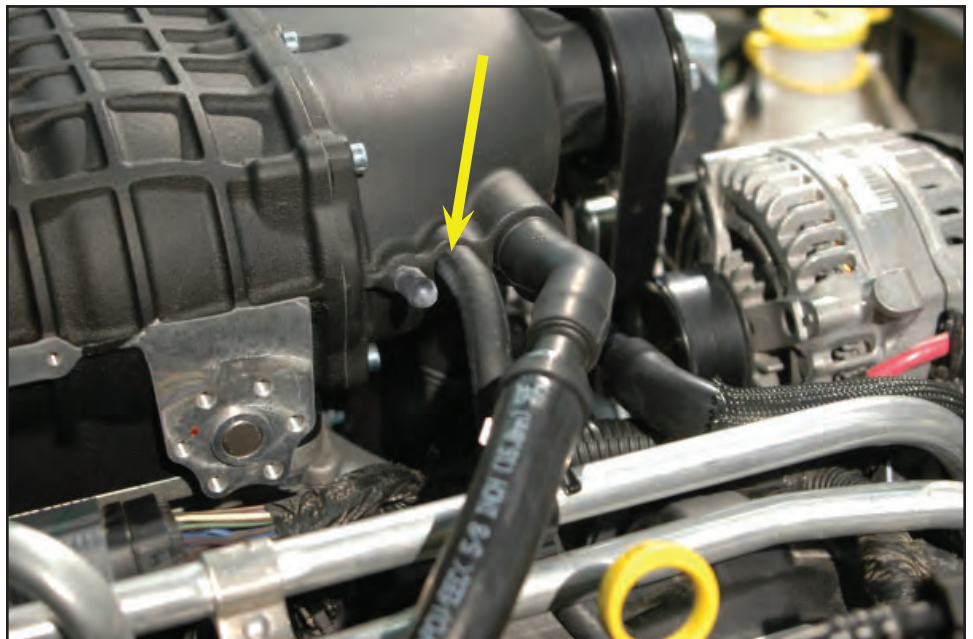

154. Connect the brake booster hose to the left hand side hose barb on the supercharger inlet as shown.

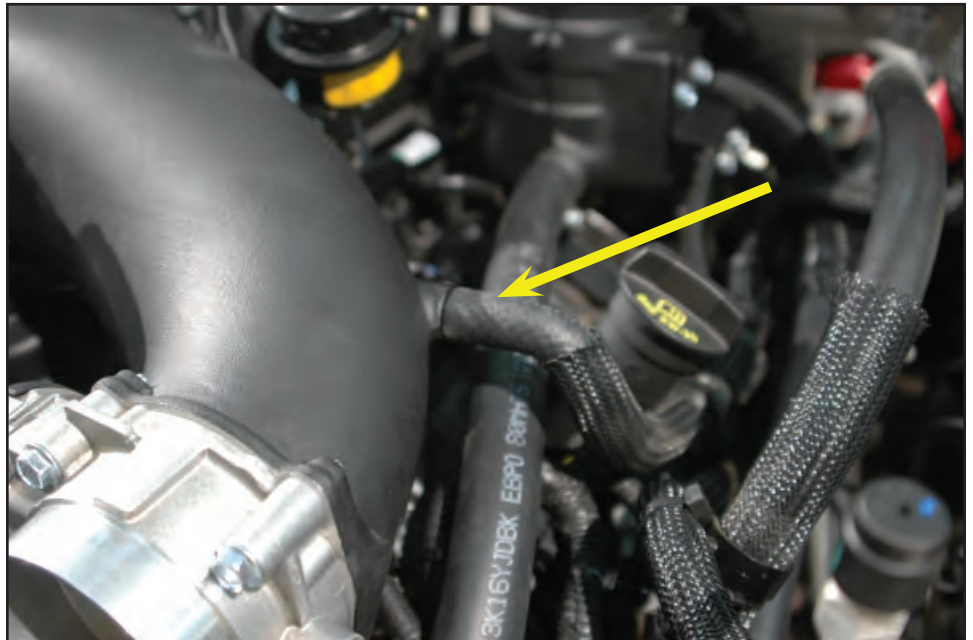

155. Align the three pins on the bottom of the air box with the three grommets on the air box tray and press the air box back in original position. This will "snap" in place.



156. Connect the OEM air box to the throttle body and air box and secure with the OEM clamps.



157. Secure the air box in place with the two original mounting bolts and tighten using a 10mm wrench.

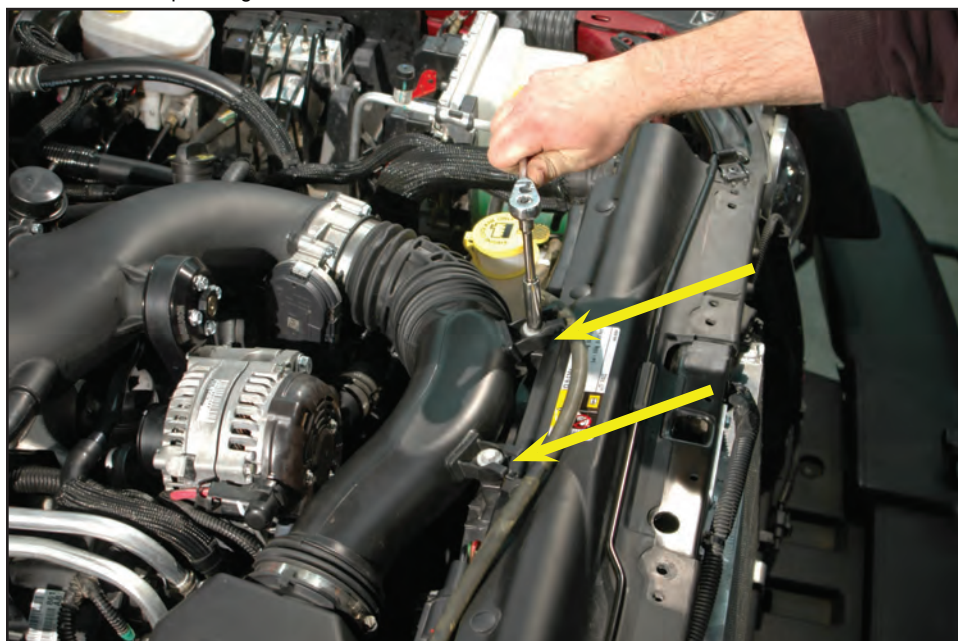

158. Press the overflow hose back on the two clamps by the mounting bolts of the air tube.



159. Reinstall the grille-fascia on the vehicle aligning the mounting tabs on the bottom and press into position.



160. Reinstall the six push pin rivets in the top of the grill-fascia by pressing the rivet in place and then pushing the locking pin down.



161. Reconnect the right and left hand side turn signal plugs.



162. Cut 1-1/2" off the end of the PCV hose on the right hand side of the engine and reconnect to the air box hose barb.

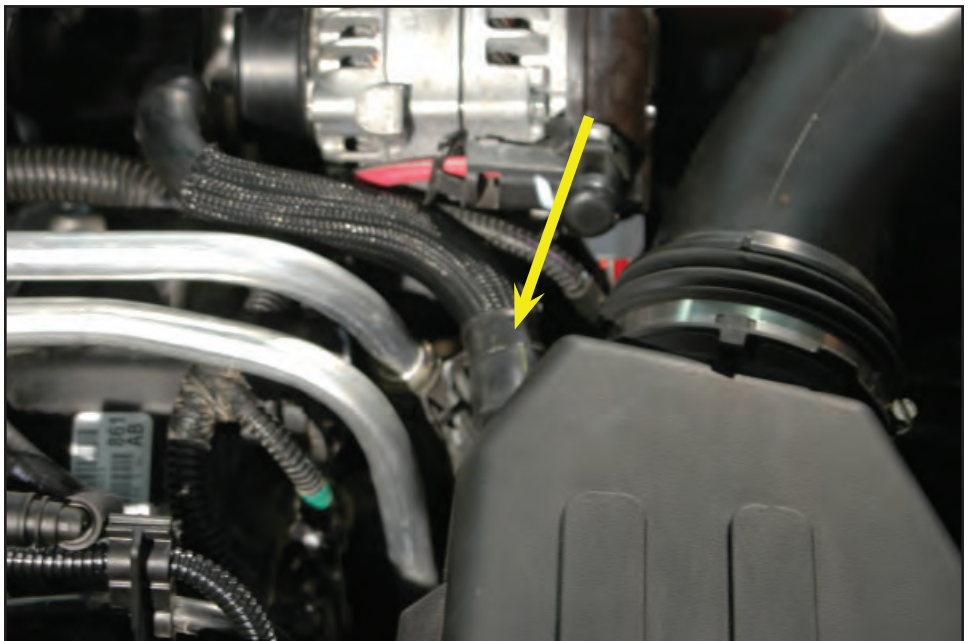

163. Reconnect the battery negative terminal and secure with 10mm wrench.



Don't forget to follow step #1 to tune your engine prior to starting it.



164. Remove the zip ties holding the fire-wall cross-over wiring harness up and out of the way, and reconnect to the original mounting studs with the OEM push on harness clips.



165. **Fill the intercooler system using ONLY the Jeep recommended mixture** of coolant and distilled water. Top off your coolant system at this time as well using the Jeep recommended coolant mixture. Have someone turn the ignition switch to the accessory mode to trigger the pump on for 5 -10 seconds. **Do not start the vehicle.** This will circulate the fluid. Check for fuel leaks at this time too. Fill the intercooler reservoir while the pump circulates. Repeat this process until the system is full. Check for coolant leaks throughout the system.



166. Reconnect the window washing tube to the mounting clip and set your hood back on the hood prop.



167. Start the engine and check for coolant, and fuel leaks. Also check supercharger belt alignment. Test drive vehicle for the first few miles under normal driving conditions. **Do not attempt any wide open throttle runs.** Check for any unusual sounds, vibrations, or engine miss-fires. The supercharger does have a slight whining noise under boost conditions, which is normal. After initial test let engine cool down, and recheck coolant levels.

168. After the initial test drive gradually work the vehicle to wide open throttle runs. Listen for any engine detonation (pinging). If engine detonation is detected let up on the throttle immediately. Most detonation is caused by low octane gasoline still in the tank. Premium fuel is required. Install the provided "Use Premium Fuel Only" sticker to the inside of the fuel filler door. Enjoy your new supercharger!

After you finish your installation and road test your vehicle, please fill out the warranty registration. This can be found on our website.

If you have questions about your vehicles performance, please check with your installation facility.

NOTE: Remember that the provided oil filter on the 2012-2013 model year is a two element system. The upper element is attached to the oil filter housing lid and will likely come up with the lid upon removal. The lower element with the gasket will remain behind. You will need to use a "hook" tool or piece of hard wire bent into a hook to pull this element out when cleaning oil filters. The two-stage filter provided is servicable. For cleaning your new K and P filter, see the manufacturers website:

<http://kandengineering.com/cleaning.shtml>

PREMIUM GASOLINE FUEL REQUIRED

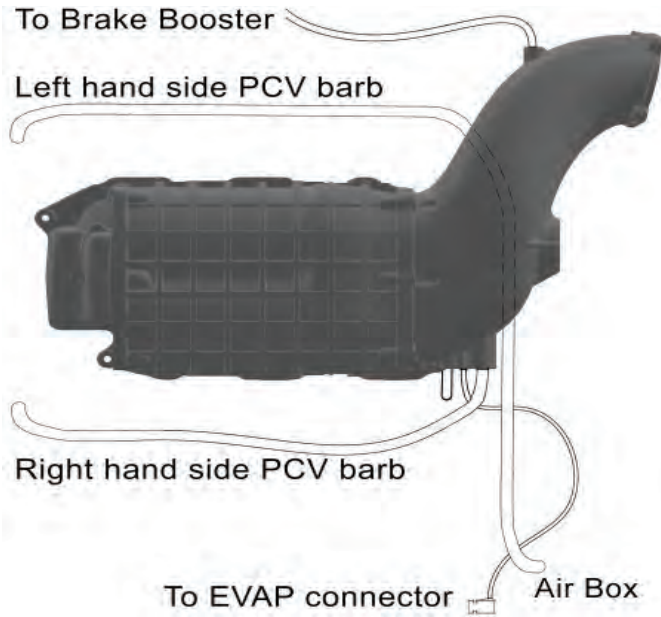

Vacuum Routing Diagram

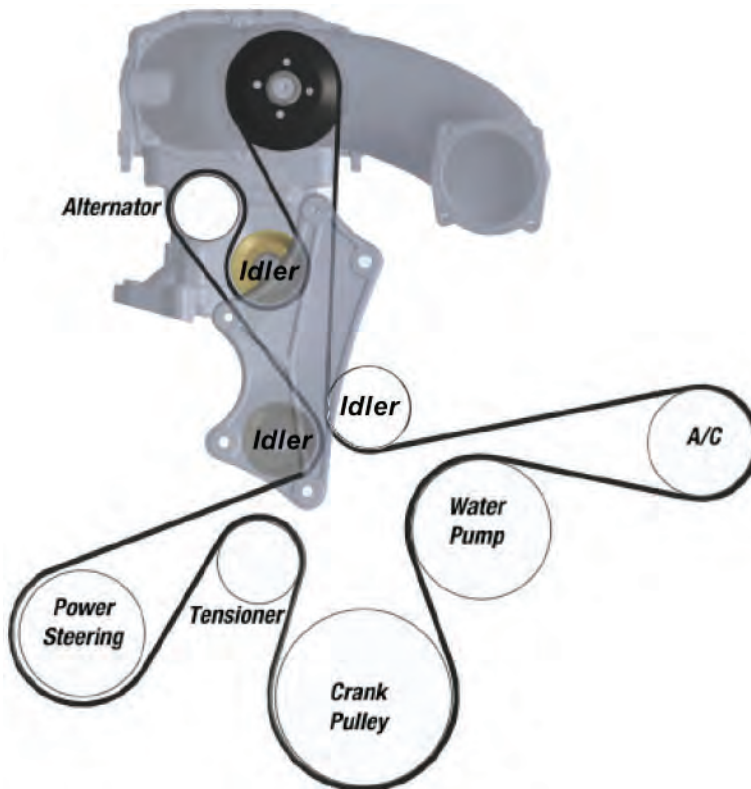

Belt Routing Diagram

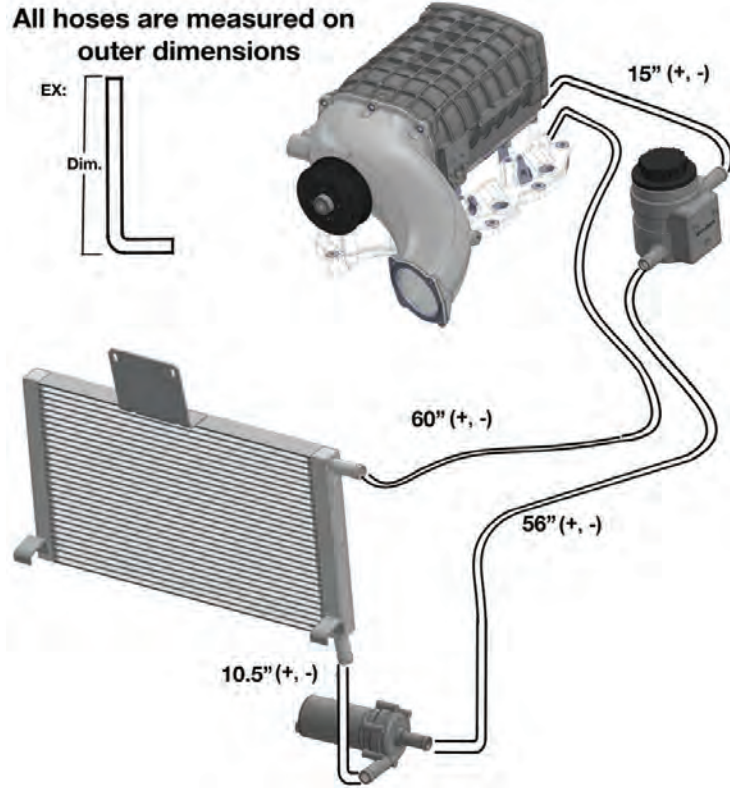

IC Plumbing Diagram

NOTES

NOTES



Please enjoy your "Magnuson SuperCharged" performance responsibly.

Use only Premium Gasoline Fuel, 91 Octane or better.

MAGNUSON
SUPERCHARGERS